

Chapter 1. Disassembly & Assembly Guide

1-3. Disassembly & Assembly

- Main Section -

MS-1 Main Section Disassembly(15-inch Model)

Battery Pack

1)

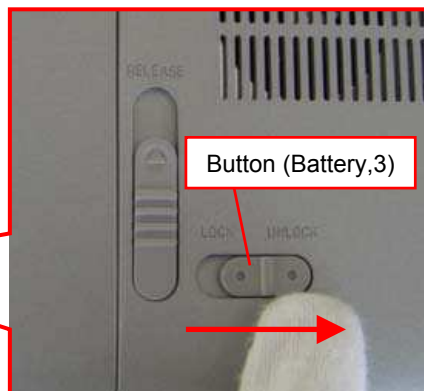
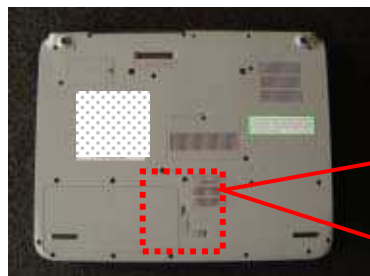

Slide the Button (Battery,3) to the "UNLOCK" side.

2)

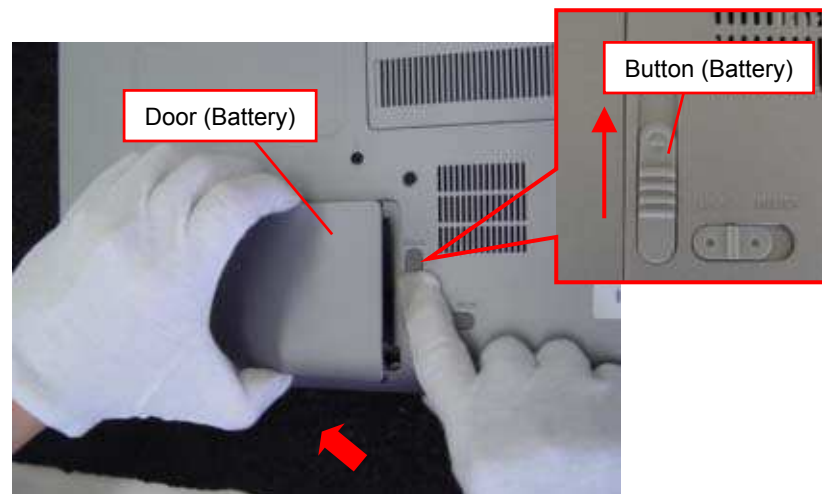

Slide the Button (Battery) in the direction of the arrow, and remove the Door (Battery) .

3)



Remove the Battery Pack.

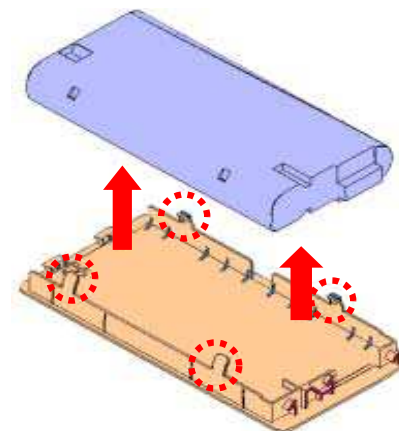

*There are four detents. Remove the Battery from one side detents (two places) .

Screws(Bottom)

1)

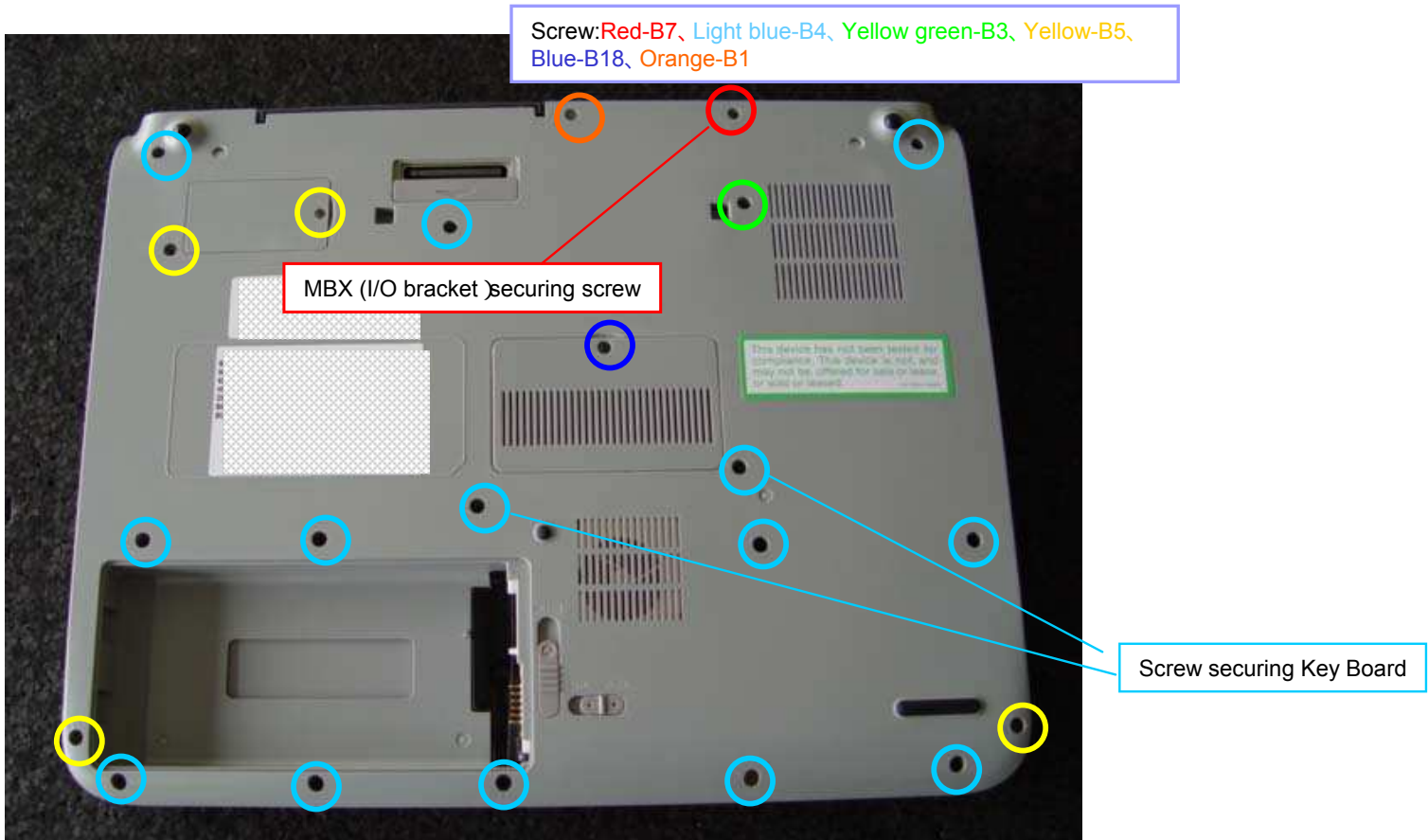

Remove the 22 screws (The Screws of the Palmrest are not denoted).

Keyboard

1)

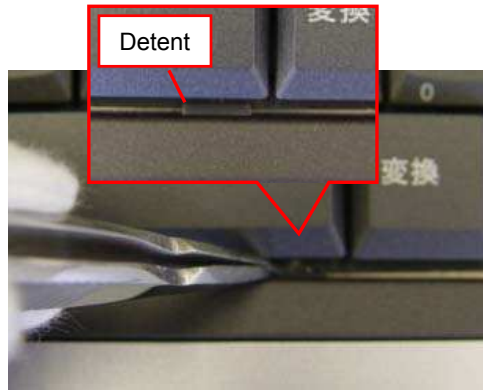
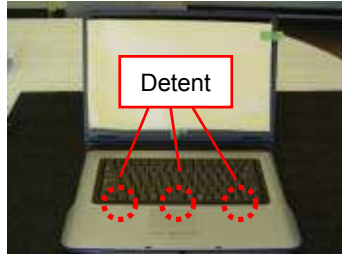

Disengage the three Detents.

*Press them lightly, and the keyboard is unlocked.

*Detents are located under the Ctrl, Space and End keys.

2)



Raise the Keyboard.

3)

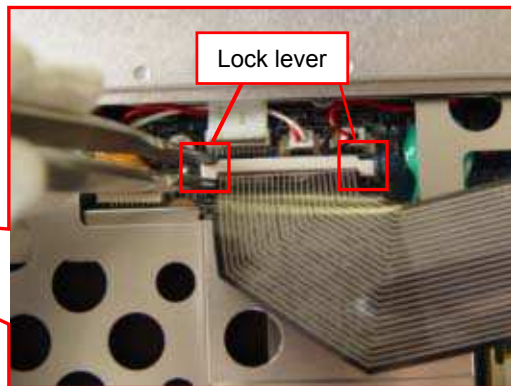
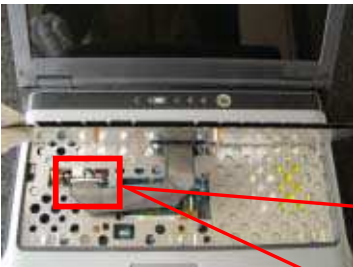

Slide the Lock lever upward vertically to unlock the FPC.

4)

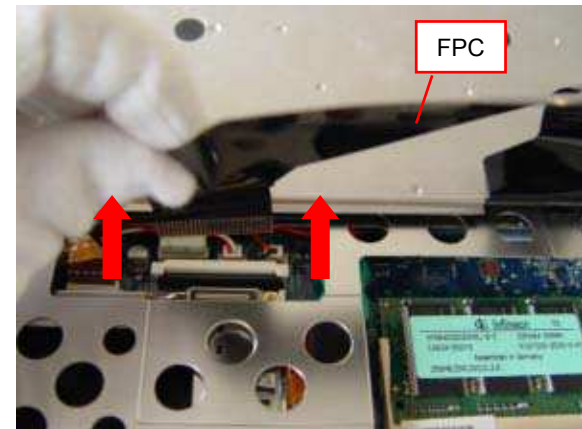

Remove the FPC vertically.

Palmrest

1)

Screw:Blue-B7,Red-B4

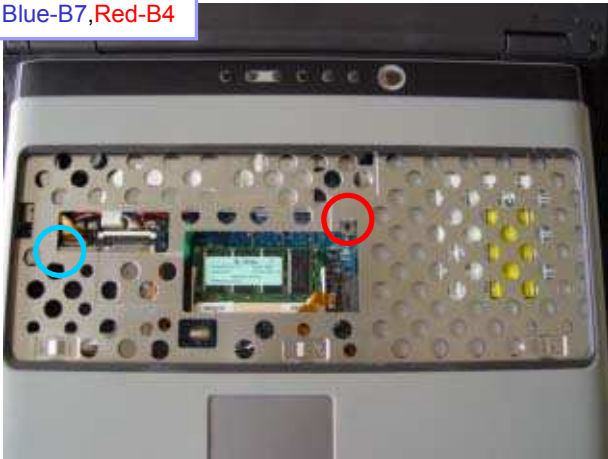

Remove the two Screws.

2)

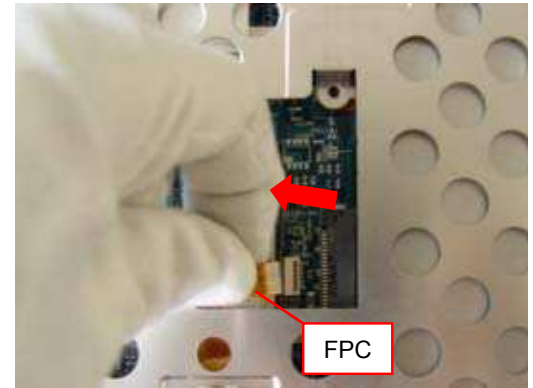

Pull out the FPC vertically.

3)

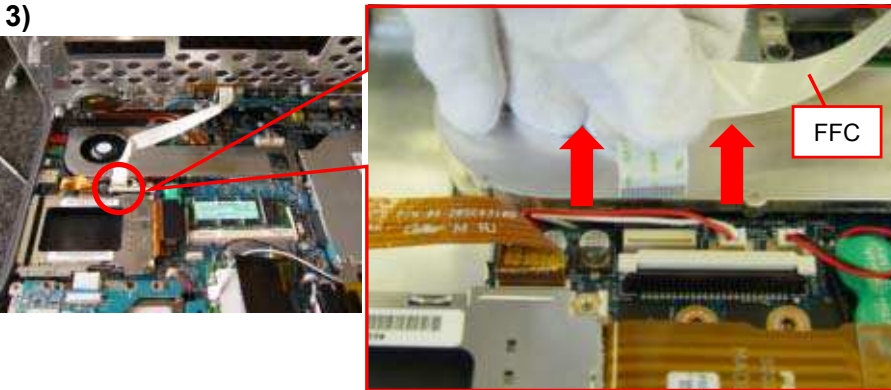

Raise the Palmrest lightly, and remove the FFC vertically.

4)

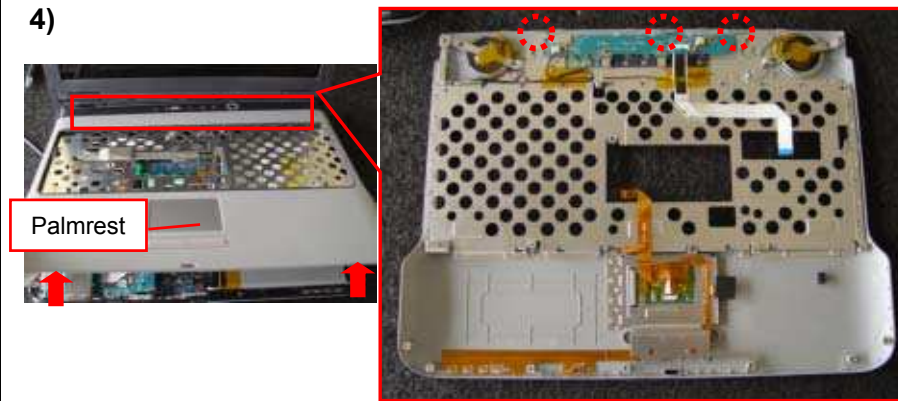

Remove the Palmrest.
*There are three detents.

Bluetooth Module

Bluetooth Equipped Model

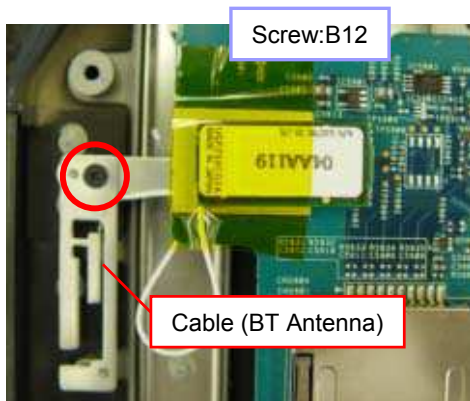
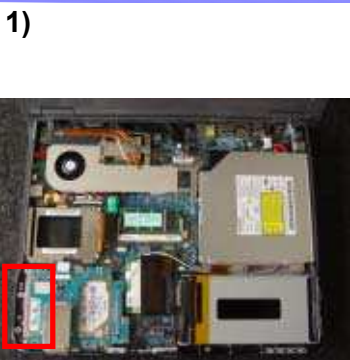

Remove the Screw.

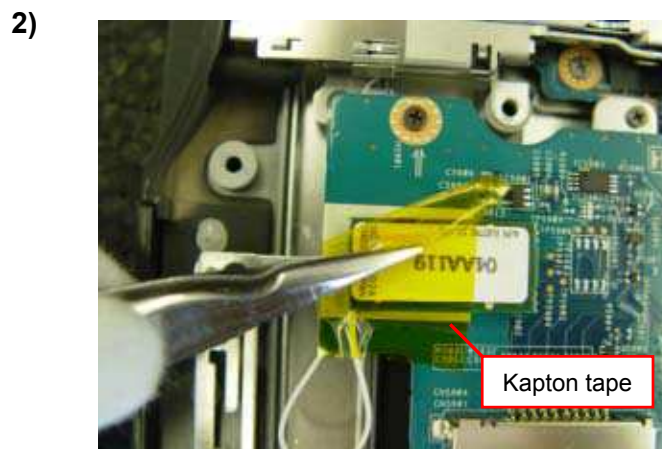

Peel off the Kapton tape.

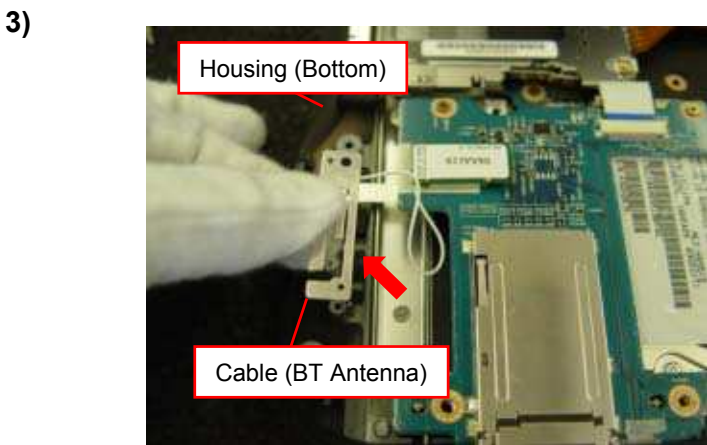

Remove the Cable (BT Antenna) from the Housing (Bottom).

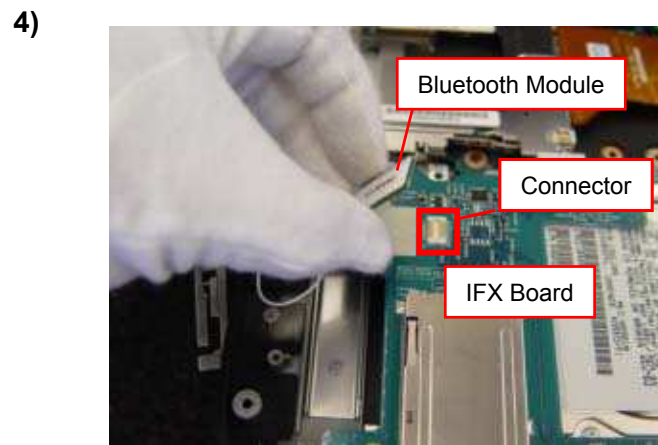

Remove the Bluetooth Module from the IFX Board.
*They are connected by the Connector.

IFX-324 Board

1)

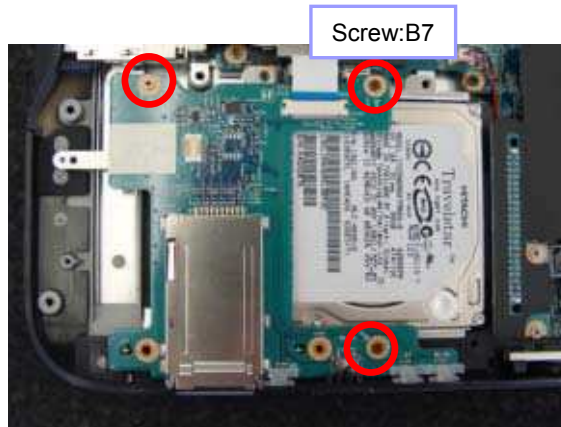

Remove the three screws.

2)

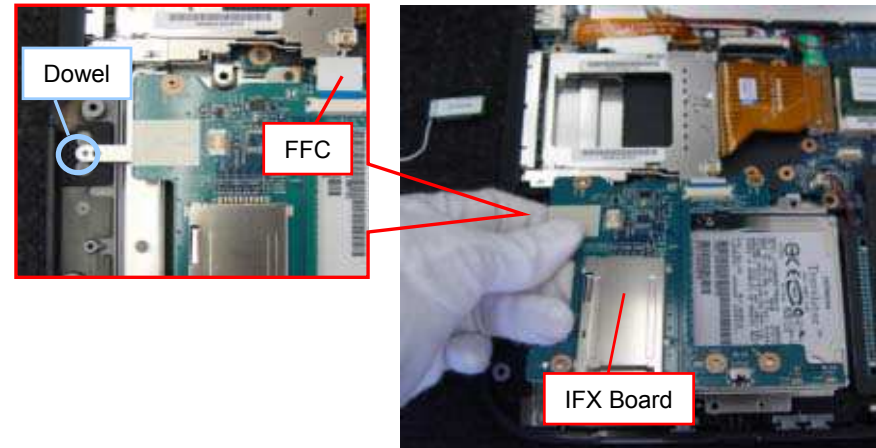

Hold the area around the dowel and raise it to remove the IFX Board.
*FFC is connected.

3)

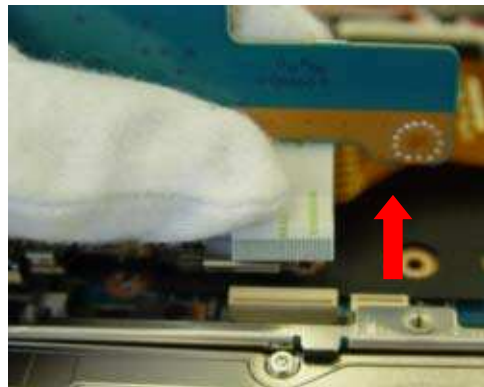

Pull the FFC vertically to remove it from the Mother Board.

HDD

1)

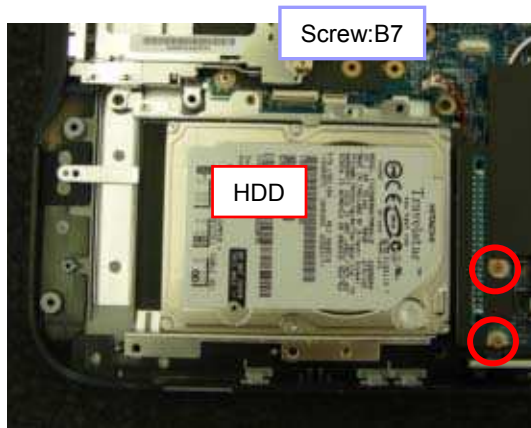

Remove the two screws.

2)

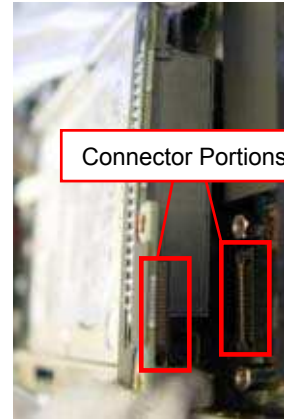

Raise the CNX Board portion that is connected to the HDD, and remove the HDD.
*The connector is located on the back of the CNX Board.

Parts of the HDD

1)

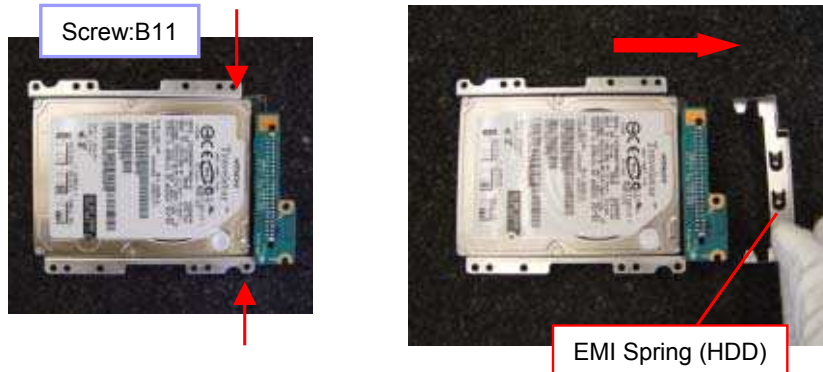

Remove the screw each on the right and left, and remove the EMI Spring (HDD).

2)

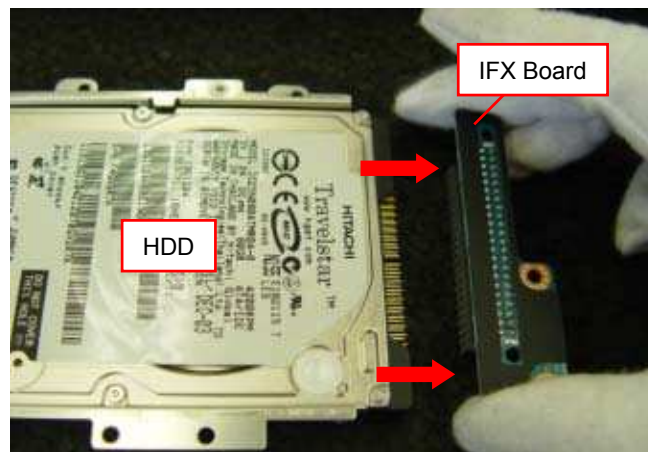

Remove the IFX Board from the HDD.

**Be careful not to bend the pins.*

3)



Remove the screw each on the right and left.

4)

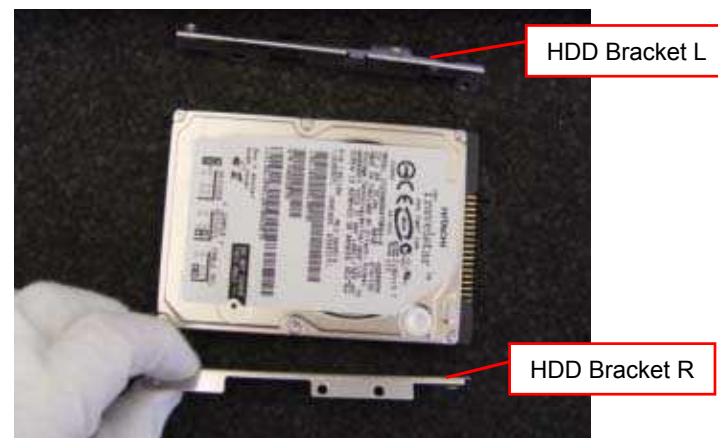

Remove the Bracket (two places).

Optical Disc Drive

1)

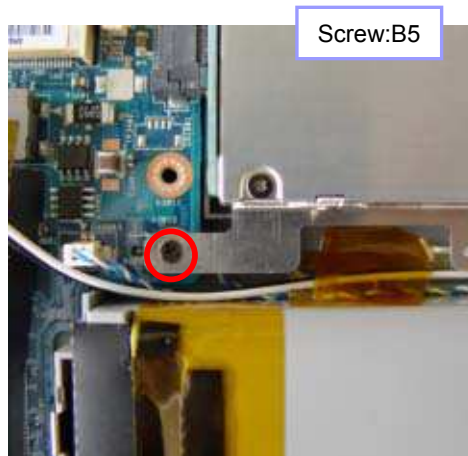
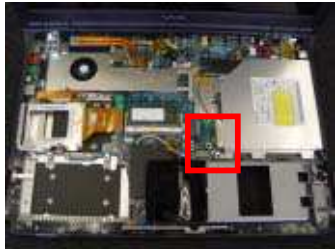

Remove the Screw.

2)

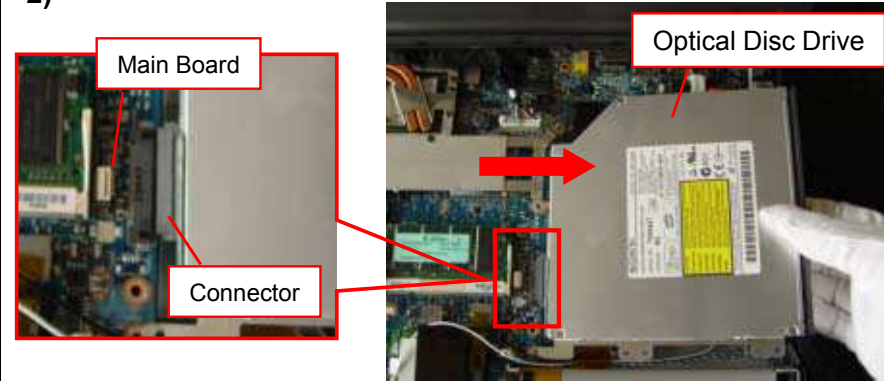

Slide the Optical Disc Drive in the direction of the arrow to remove it.
*The Connector is connected to the Main Board.

LCD Section-1

1)

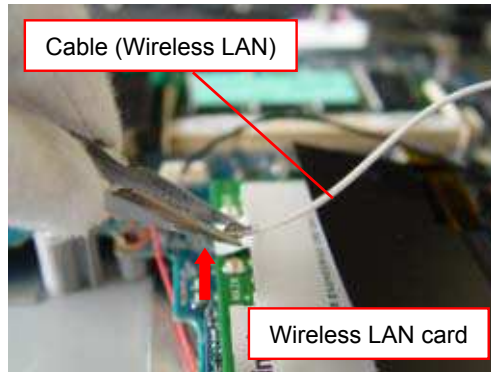
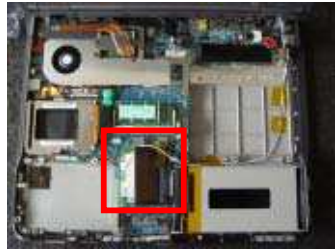

Disconnect the Cable (Wireless LAN) from the Wireless LAN Card.

**Disconnect the Connector vertically with the tweezers or the like.*

2)

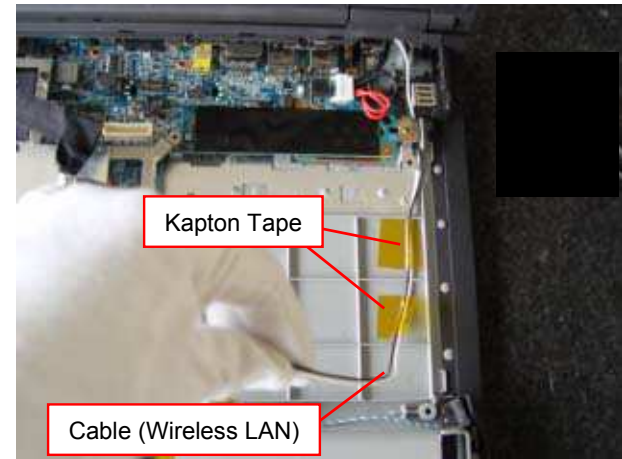

Peel off the Kapton Tape (two places), and remove the Cable.

3)

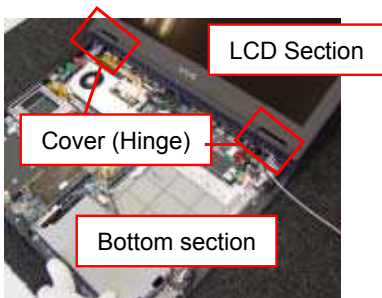

Remove the Cover (two places)

**Open the LCD as wide as possible, and hold the bottom section. Flip the large detent on the front side upward, and the Cover is easy to remove.*

4)

LCD Section-2

1)

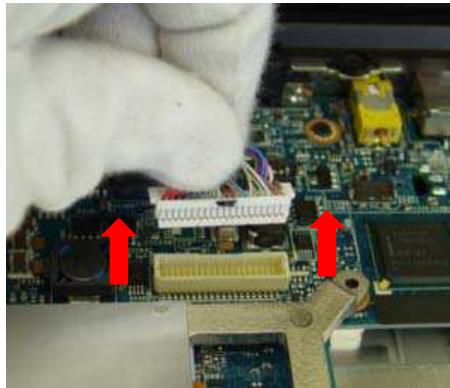
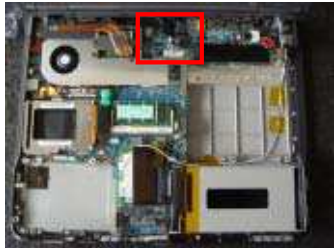

Disconnect the Harness coming from the LCD.

2)



Remove the two screws on the rear.

3)

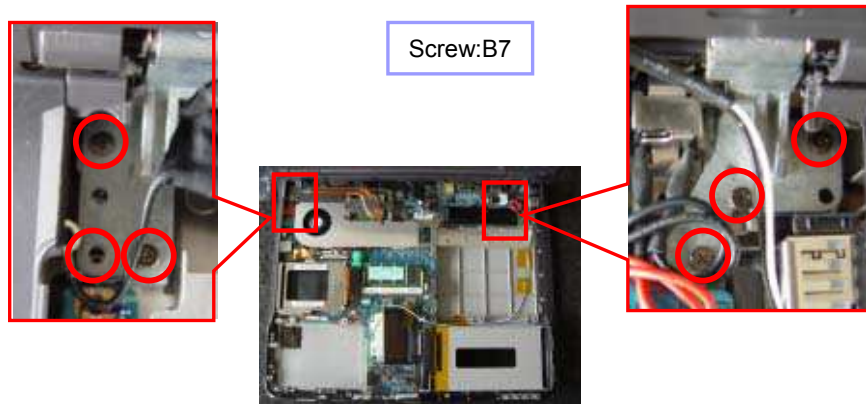

Remove the three Screws each on the right and left.

***Hold the LCD Section not to tumble it while at work.**

4)



Raise the LCD Section on your both hands to remove it.

Display Base

1)

Screw:B1



Remove the seven screws.

2)

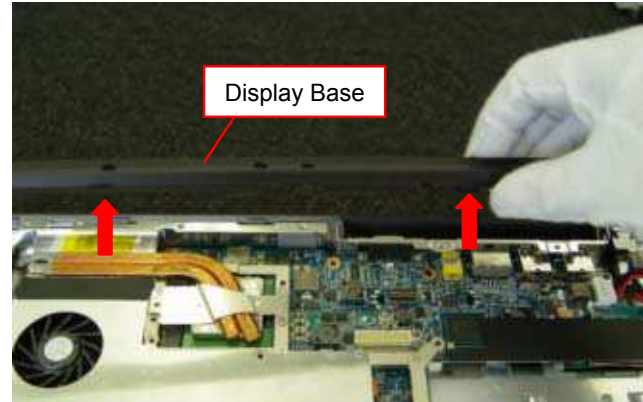

Remove the Display Base.

Remark

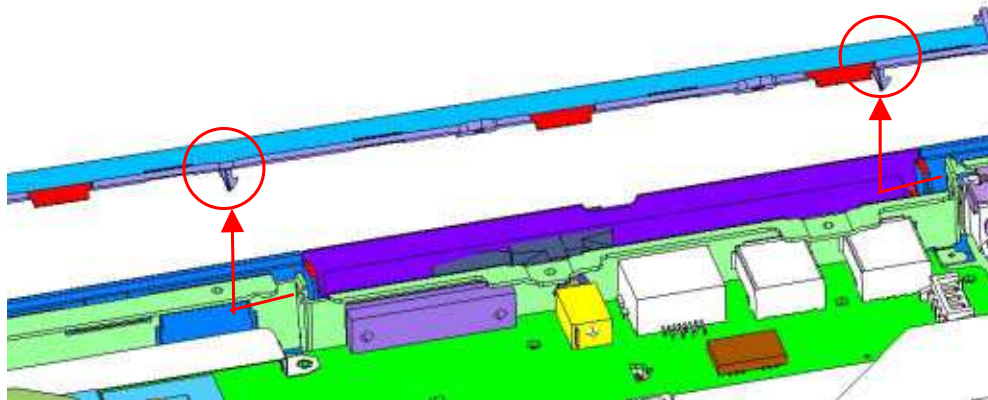
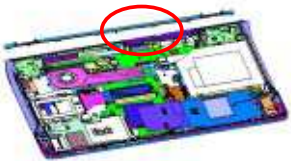

*It is recommended to disengaging the detents first in the direction of the arrows (left).

Fin(Thermal Module)

1)

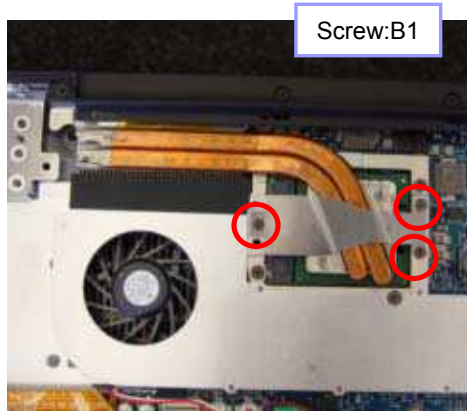

Remove the three screws.

2)

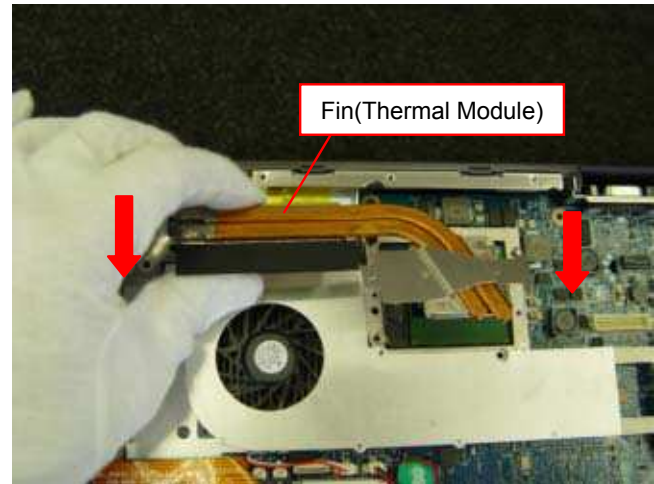

Pull out the Fin (Thermal Module) toward you.

Remark

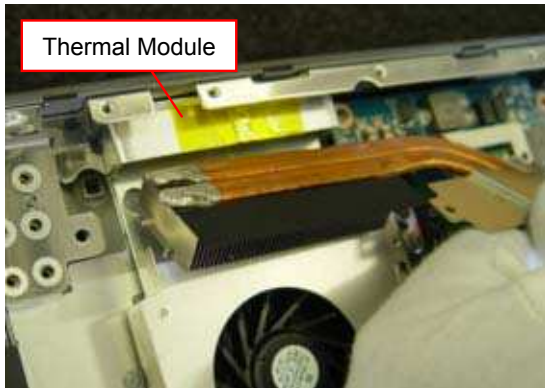

*Pull out the Fin from metallic box of the Thermal Module to remove it.

CPU

1)

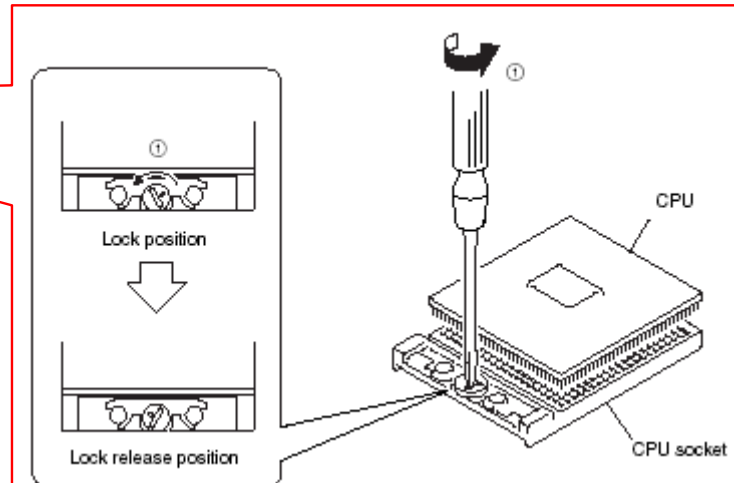
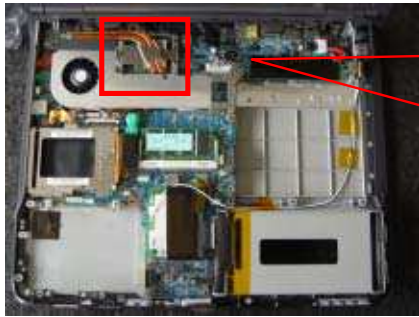

Unlock the CPU by using a 4 mm flat head screwdriver as shown in the picture.

2)

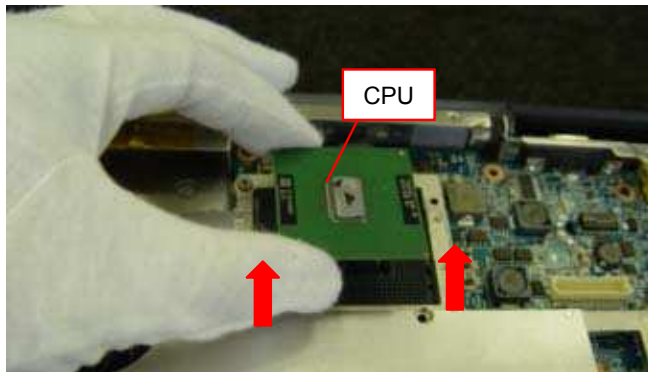

Raise the CPU upward vertically to remove.
***Be careful not to bend the pins.**

Thermal Module

1)

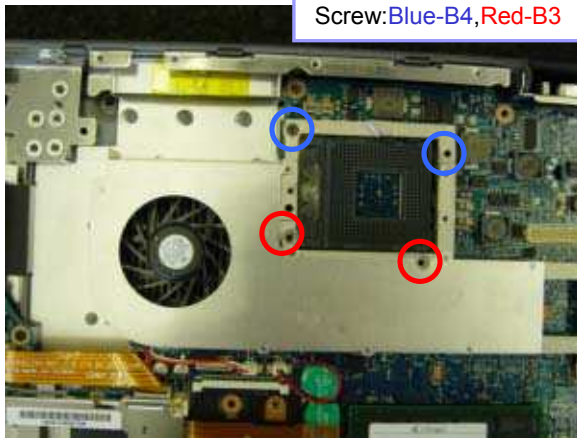

Remove the four screws.

2)

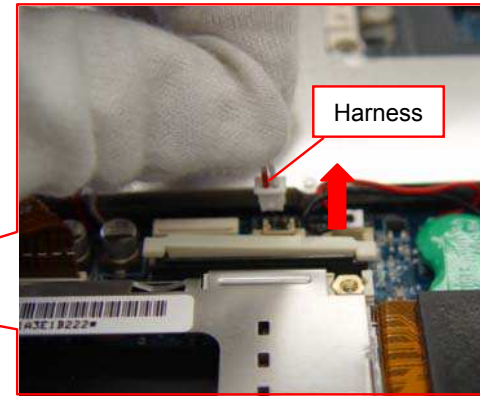
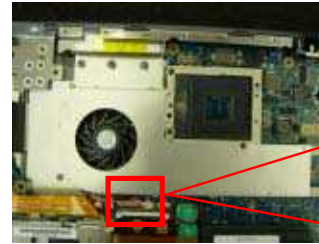

Disconnect the Harness vertically.

3)

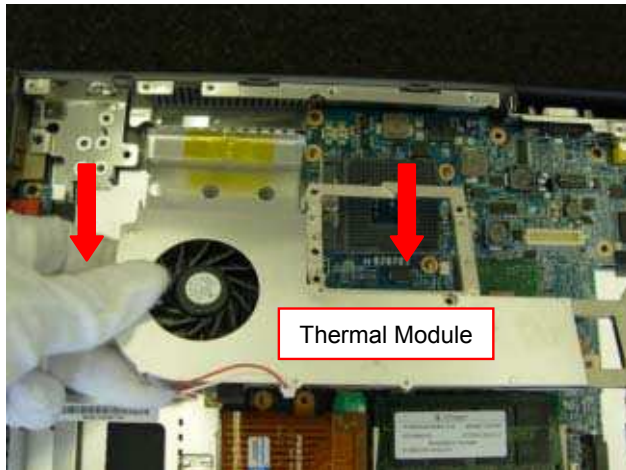

Pull the Thermal Module toward your and remove it.

Mother Board-1

1)

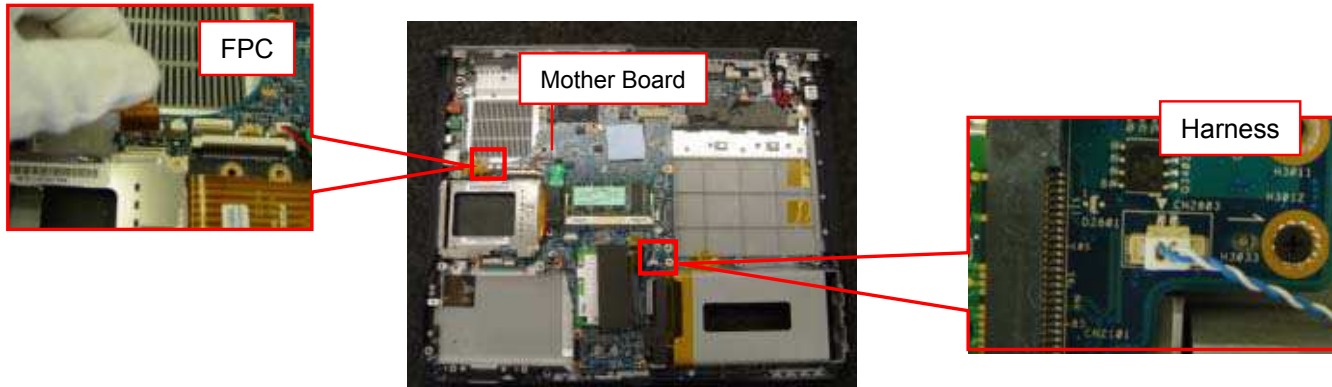

Disconnect the Harness and FPC from the Mother Board vertically.

2)

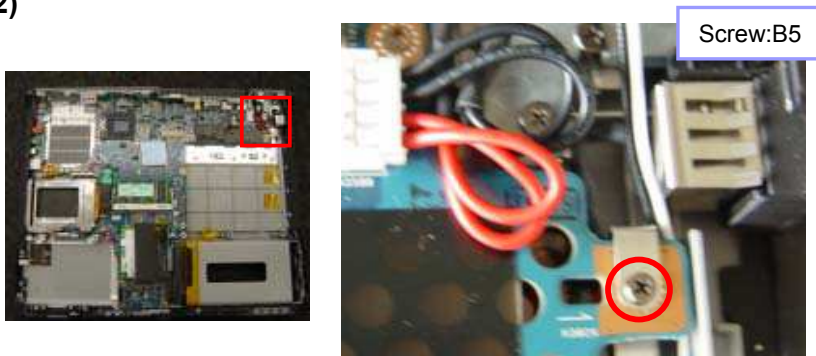

Remove the one screw.

3)

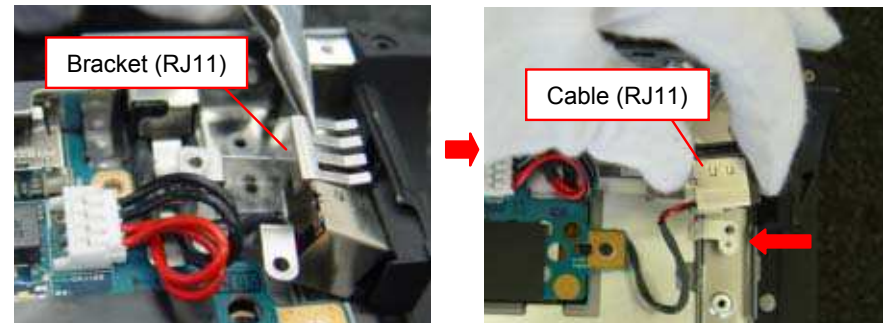

Remove the Bracket (RJ11) and Cable (RJ11) .

Mother Board-2

1)

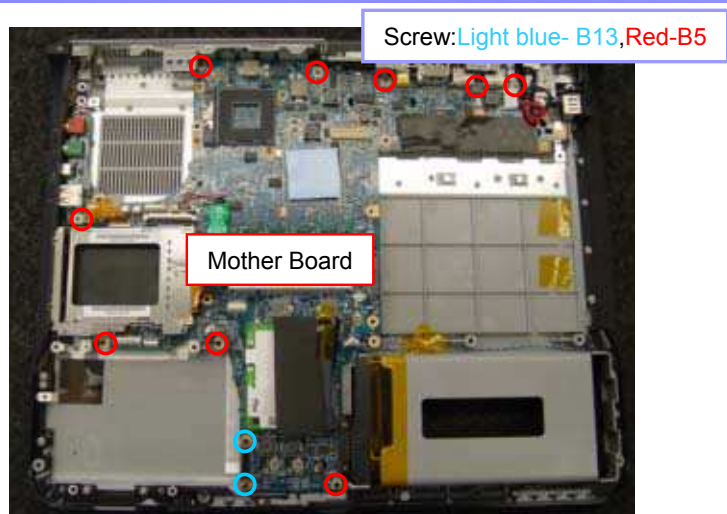

Remove the 11 screws.

*B13---Use a 4 mm socket wrench.

2)

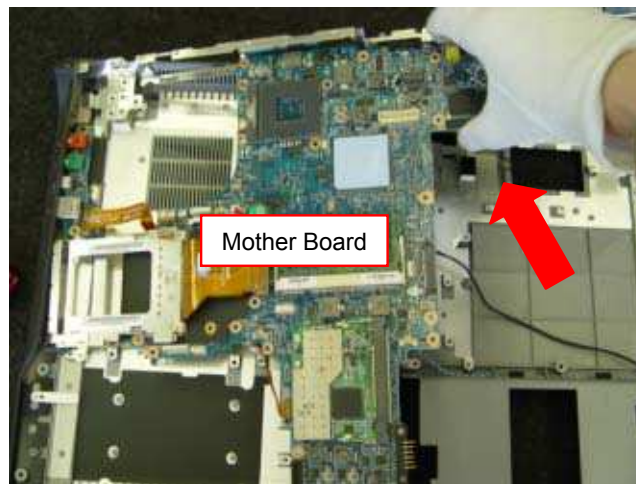

Raise the Mother Board from right side.

3)

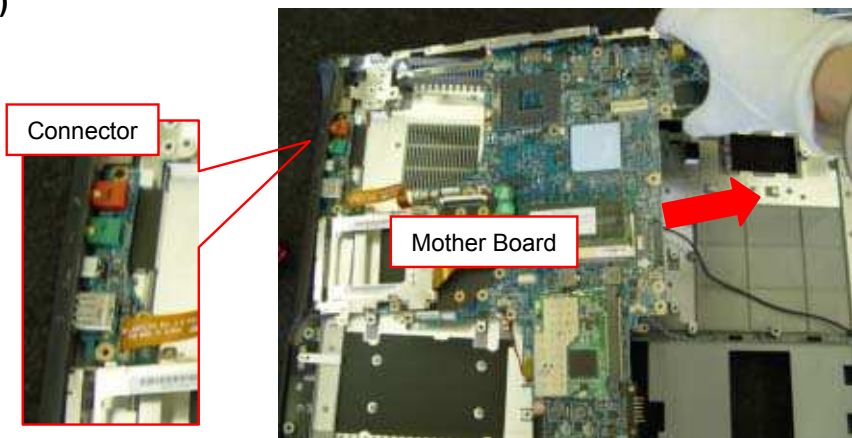

Pull out the Mother Board to the right to remove.

*Pay attention to the connector. It is easy to be caught to somewhere.

CNX-245 Board,Cable (ODD Eject)

1)

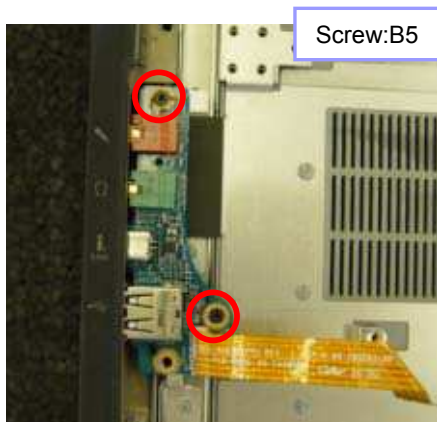
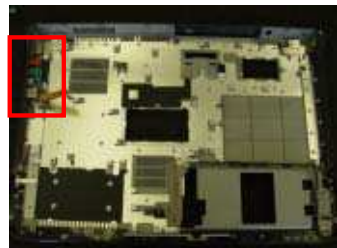

Remove the two screws.

2)

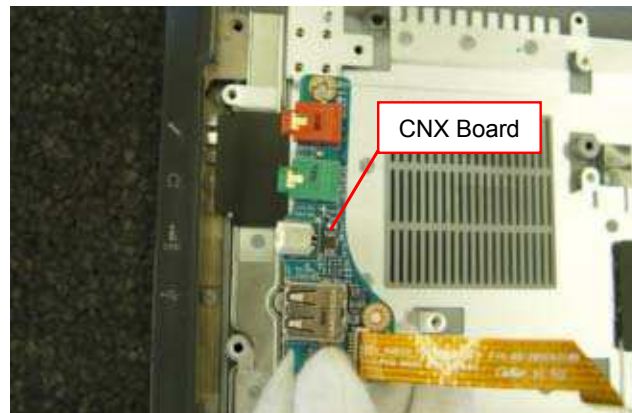

Remove the CNX Board.

3)

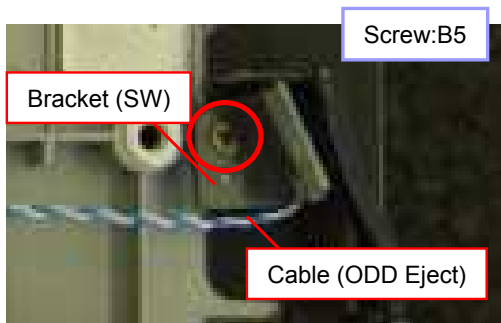
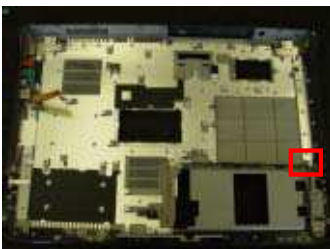

Remove the one screw and the Bracket (SW) .

4)

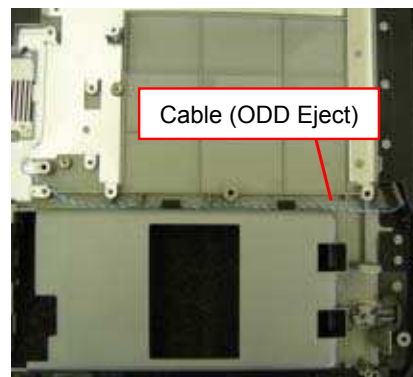

Remove the Cable (ODD Eject) .

Parts of the Housing (Bottom)

1)

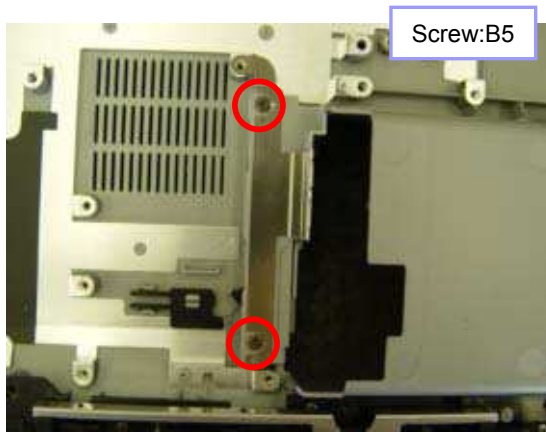
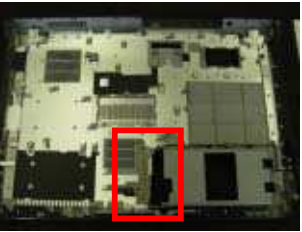

Remove the two screws.

2)

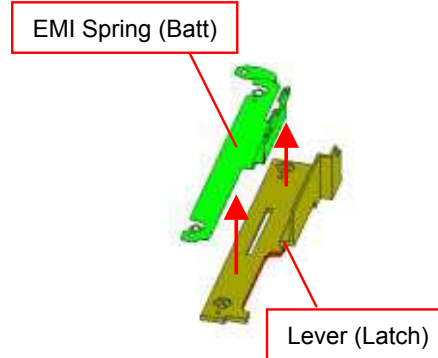
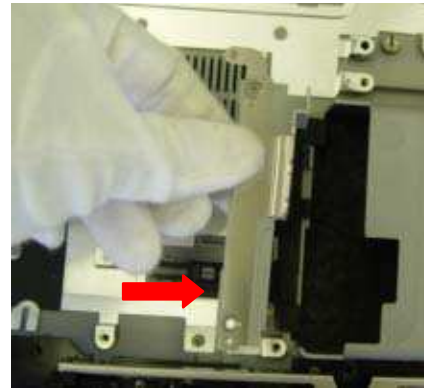

Remove the part indicated by the arrow.

* Disassembly the EMI Spring (BATT) and Lever (Latch) .

3)

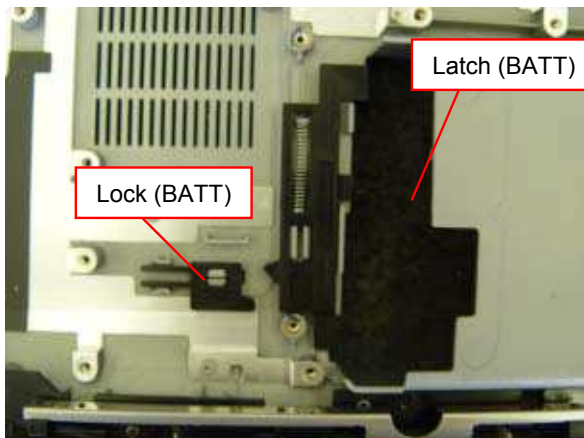
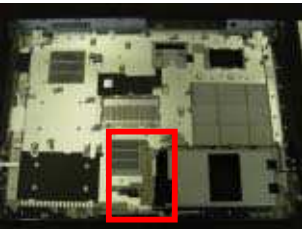

Remove the Lock (BATT) and the Latch (BATT) .

4)

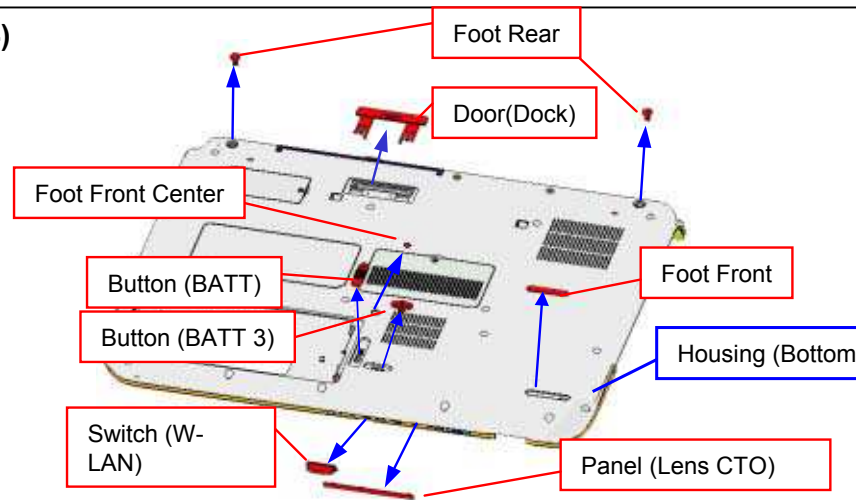

Remove the ten parts shown above from the bottom of the Housing.

Update History

[ADD]---Addition [DEL]---Deletion [CHG]---Change [COR]---Correction [MA]---Model Addition

Date		Contents	Version No.
-	-	-	-