

# SERVICE MANUAL

*notebook*

M3C (M350C / M360C)

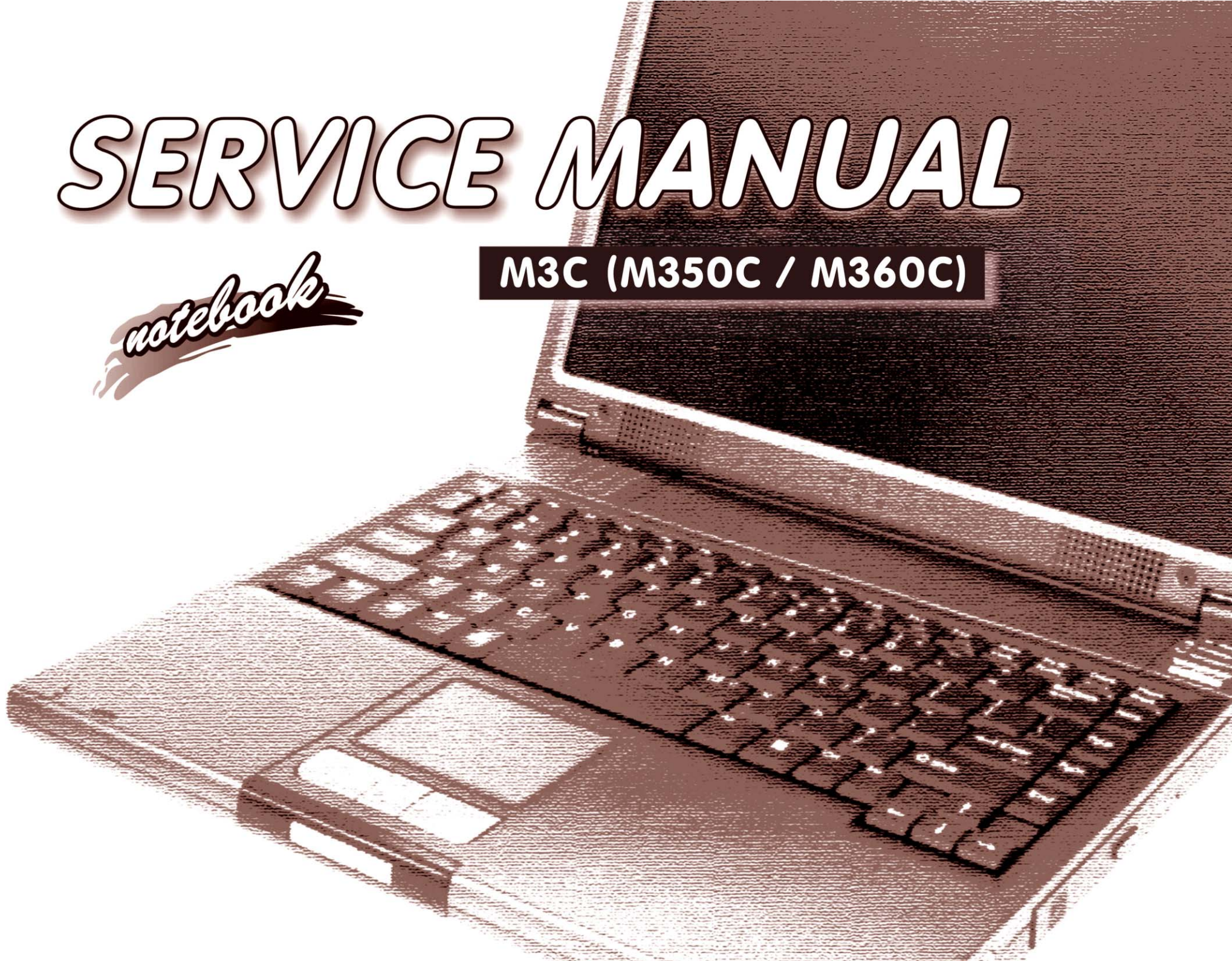

**Notebook Computer**

**M350C/M360C**

**Service Manual**

### Notice

The company reserves the right to revise this publication or to change its contents without notice. Information contained herein is for reference only and does not constitute a commitment on the part of the manufacturer or any subsequent vendor. They assume no responsibility or liability for any errors or inaccuracies that may appear in this publication nor are they in anyway responsible for any loss or damage resulting from the use (or misuse) of this publication.

This publication and any accompanying software may not, in whole or in part, be reproduced, translated, transmitted or reduced to any machine readable form without prior consent from the vendor, manufacturer or creators of this publication, except for copies kept by the user for backup purposes.

Brand and product names mentioned in this publication may or may not be copyrights and/or registered trademarks of their respective companies. They are mentioned for identification purposes only and are not intended as an endorsement of that product or its manufacturer.

Version 1.0  
July 2003

### Trademarks

**Intel**<sup>®</sup> and **Pentium**<sup>®</sup> are registered trademarks of Intel Corporation.

**Windows**<sup>®</sup> is a registered trademark of Microsoft Corporation.

Other brand and product names are trademarks and./or registered trademarks of their respective companies.

## About this Manual

This manual is intended for service personnel who have completed sufficient training to undertake the maintenance and inspection of personal computers.

It is organized to allow you to look up basic information for servicing and/or upgrading components of the *M350C*/*M360C* series notebook PC.

The following information is included:

Chapter 1, Introduction, provides general information about the location of system elements and their specifications.

Chapter 2, Disassembly, provides step-by-step instructions for disassembling parts and subsystems and how to upgrade elements of the system.

Appendix A, Part Lists

Appendix B, Schematic Diagrams

Appendix C, Updating the FLASH ROM BIOS

### **IMPORTANT SAFETY INSTRUCTIONS**

When using your telephone equipment, basic safety precautions should always be followed to reduce the risk of fire, electric shock and injury to persons, including the following:

1. Do not use this product near water, for example near a bath tub, wash bowl, kitchen sink or laundry tub, in a wet basement or near a swimming pool.
2. Avoid using a telephone (other than a cordless type) during an electrical storm. There may be a remote risk of electrical shock from lightning.
3. Do not use the telephone to report a gas leak in the vicinity of the leak.
4. Use only the power cord and batteries indicated in this manual. Do not dispose of batteries in a fire. They may explode. Check with local codes for possible special disposal instructions.
5. This product is intended to be supplied by a Listed Power Unit (DC Output 20V, 3.25A).

### **CAUTION**

Always disconnect all telephone lines from the wall outlet before servicing or disassembling this equipment.

**TO REDUCE THE RISK OF FIRE, USE ONLY NO. 26 AWG OR LARGER,  
TELECOMMUNICATION LINE CORD**

## Instructions for Care and Operation

The notebook computer is quite rugged, but it can be damaged. To prevent this, follow these suggestions:

1. **Don't drop it, or expose it to shock.** If the computer falls, the case and the components could be damaged.



2. **Keep it dry, and don't overheat it.** Keep the computer and power supply away from any kind of heating element. This is an electrical appliance. If water or any other liquid gets into it, the computer could be badly damaged.

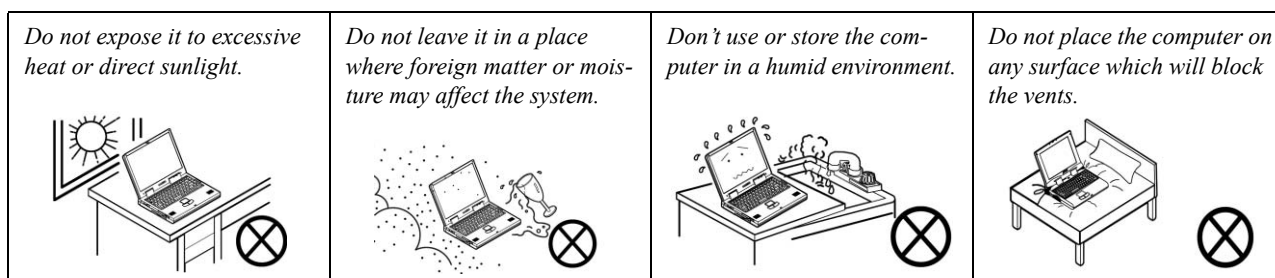

3. **Follow the proper working procedures for the computer.** Shut the computer down properly and don't forget to save your work. Remember to periodically save your data as data may be lost if the battery is depleted.

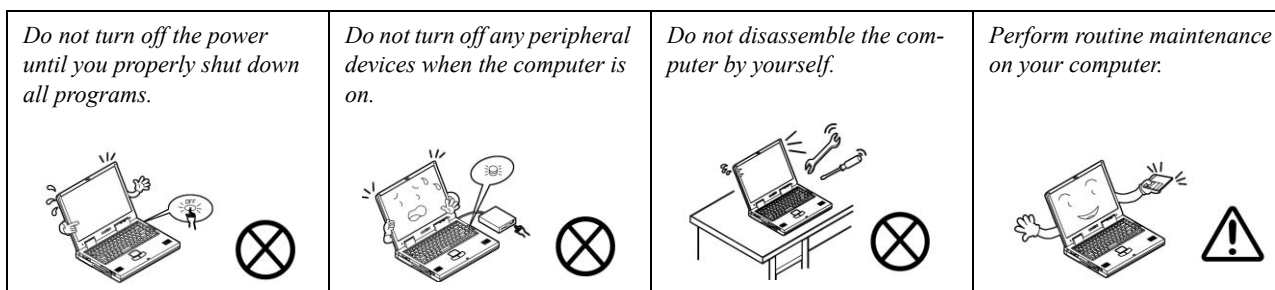

4. **Avoid interference.** Keep the computer away from high capacity transformers, electric motors, and other strong magnetic fields. These can hinder proper performance and damage your data.
5. **Take care when using peripheral devices.**

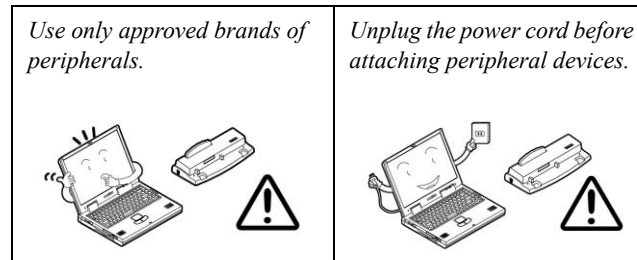

## Power Safety

The computer has specific power requirements:

- Only use a power adapter approved for use with this computer.
- Your AC adapter may be designed for international travel but it still requires a steady, uninterrupted power supply. If you are unsure of your local power specifications, consult your service representative or local power company.
- The power adapter may have either a 2-prong or a 3-prong grounded plug. The third prong is an important safety feature; do not defeat its purpose. If you do not have access to a compatible outlet, have a qualified electrician install one.
- When you want to unplug the power cord, be sure to disconnect it by the plug head, not by its wire.
- Make sure the socket and any extension cord(s) you use can support the total current load of all the connected devices.
- Before cleaning the computer, make sure it is disconnected from any external power supplies.

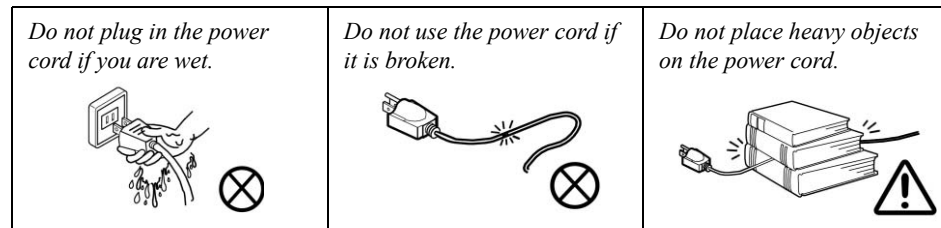

### Power Safety Warning

Before you undertake any upgrade procedures, make sure that you have turned off the power, and disconnected all peripherals and cables (including telephone lines). It is advisable to also remove your battery in order to prevent accidentally turning the machine on.

## Battery Precautions

- Only use batteries designed for this computer. The wrong battery type may explode, leak or damage the computer.
- Recharge the batteries using the notebook's system. Incorrect recharging may make the battery explode.
- Do not try to repair a battery pack. Refer any battery pack repair or replacement to your service representative or qualified service personnel.
- Keep children away from, and promptly dispose of a damaged battery. Always dispose of batteries carefully. Batteries may explode or leak if exposed to fire, or improperly handled or discarded.
- Keep the battery away from metal appliances.
- Affix tape to the battery contacts before disposing of the battery.
- Do not touch the battery contacts with your hands or metal objects.



### Battery Disposal

The product that you have purchased contains a rechargeable battery. The battery is recyclable. At the end of its useful life, under various state and local laws, it may be illegal to dispose of this battery into the municipal waste stream. Check with your local solid waste officials for details in your area for recycling options or proper disposal.

### Caution

Danger of explosion if battery is incorrectly replaced. Replace only with the same or equivalent type recommended by the manufacturer. Discard used battery according to the manufacturer's instructions.



### Related Documents

You may also need to consult the following manual for additional information:

#### User's Manual on CD

This describes the notebook PC's features and the procedures for operating the computer and its ROM-based setup program. It also describes the installation and operation of the utility programs provided with the notebook PC.

## Contents

<b>Introduction .....</b>	<b>1-1</b>	Mainboard Overview - Top (Key Parts) .....	1-9
Overview .....	1-1	Mainboard Overview - Bottom (Key Parts) .....	1-10
System Specifications .....	1-2	Mainboard Overview - Top (Connectors) .....	1-11
Processor Options .....	1-2	Mainboard Overview - Bottom (Connectors) .....	1-12
Core Logic .....	1-2	<b>Disassembly .....</b>	<b>2-1</b>
Structure .....	1-2	Overview .....	2-1
Security .....	1-2	Maintenance Tools .....	2-2
Memory .....	1-2	Connections .....	2-2
BIOS .....	1-2	Maintenance Precautions .....	2-3
LCD .....	1-2	Disassembly Steps .....	2-4
Display .....	1-2	Removing the Battery .....	2-7
Storage .....	1-2	Removing the Hard Disk Drive and Wireless LAN .....	2-8
PC Card .....	1-2	Removing the System Memory (RAM) .....	2-10
Audio .....	1-2	Removing the CD Device .....	2-12
Keyboard .....	1-3	Removing the Modem .....	2-13
Interface .....	1-3	Removing the Processor .....	2-14
Communication .....	1-3	Removing the Keyboard .....	2-16
Power Management .....	1-3	Removing the Bottom Case .....	2-17
Power .....	1-3	Removing the Audioboard .....	2-18
Indicators .....	1-3	Removing the Multi-function board .....	2-19
Buttons .....	1-3	Removing the Mainboard .....	2-20
Environmental Spec .....	1-4	Removing the TouchPad and Click Board .....	2-21
Physical Dimensions .....	1-4	Removing the Inverter .....	2-22
Weight .....	1-4	Removing the Speakers .....	2-23
Optional .....	1-4	Removing the LCD Panel .....	2-24
Design Differences .....	1-4	Removing the PC Camera Module .....	2-24
External Locator - Top View .....	1-5	<b>Part Lists .....</b>	<b>A-1</b>
External Locator - Front & Left Side Views .....	1-6	Part List Illustration Location .....	A-2
External Locator - Right Side & Rear Views .....	1-7	Top (M350C) .....	A-3
External Locator - Bottom View .....	1-8		

## Preface

---

Bottom (M350C) .....	A-4	LVDS; CRT .....	B-11
LCD (M350C) .....	A-5	ICH4-1 (1 of 3) .....	B-12
CD-ROM Drive - QSI (M350C) .....	A-6	ICH4-2 (2 of 3) .....	B-13
CD-ROM Drive - SAMSUNG (M350C) .....	A-7	ICH4-3 (3 of 3) .....	B-14
CD-RW Drive - KME (M350C) .....	A-8	USB 2.0, Wireless LAN .....	B-15
CD-RW Drive - TEAC (M350C) .....	A-9	MDC, BT, CCT .....	B-16
Combo Drive - QSI (M350C) .....	A-10	HDD, CDROM .....	B-17
Combo Drive - TEAC-SAMSUNG (M350C) .....	A-11	LAN RTL8100BL .....	B-18
DVD-ROM Drive - QSI (M350C) .....	A-12	ROM, W517 .....	B-19
DVD-ROM Drive - TEAC (M350C) .....	A-13	TI1394 (TSB43AB21) .....	B-20
Top (M360C) .....	A-14	Hitachi H8S .....	B-21
Bottom (M360C) .....	A-15	CON .....	B-22
LCD (M360C) .....	A-16	Audio Codec ALC201 .....	B-23
CD-ROM Drive - QSI (M360C) .....	A-17	PCMCIA (ENE1410) .....	B-24
CD-ROM Drive - SAMSUNG (M360C) .....	A-18	PCMCIA Socket .....	B-25
CD-RW Drive - KME (M360C) .....	A-19	AC IN; Power Button .....	B-26
CD-RW Drive - TEAC (M360C) .....	A-20	CH7011; TV-Out .....	B-27
Combo Drive - QSI (M360C) .....	A-21	V_CORE .....	B-28
Combo Drive - TEAC-SAMSUNG (M360C) .....	A-22	Charger .....	B-29
DVD-ROM Drive - QSI (M360C) .....	A-23	Multi-Function Board .....	B-30
DVD-ROM Drive - TEAC (M360C) .....	A-24	<b>Updating the FLASH ROM BIOS..... C-1</b>	
<b>Schematic Diagrams..... B-1</b>			
System Block Diagram .....	B-2		
Socket 479 - 1 of 2 .....	B-3		
Socket 479 - 2 of 2 .....	B-4		
Montara GM-1 .....	B-5		
Montara GM-2 .....	B-6		
Montara GM-3 .....	B-7		
DDRAM .....	B-8		
DDR Termination .....	B-9		
Clock Generator .....	B-10		

# 1: Introduction

## Overview

This manual covers the information you need to service or upgrade the *M350C/M360C* series notebook computer. Information about operating the computer (e.g. getting started, and the *Setup* utility) is in the *User's Manual*. Information about drivers (e.g. VGA & audio) is also found in *User's Manual*. That manual is shipped with the computer.

Operating systems (e.g. *DOS*, *Windows 9x*, *Windows NT 4.0*, *Windows 2000*, *Windows XP*, *OS/2 Warp*, *UNIX*, etc.) have their own manuals as do application software (e.g. word processing and database programs). If you have questions about those programs, you should consult those manuals.

The *M350C/M360C* series notebook is designed to be upgradeable. See *“Disassembly” on page 2 - 1* for a detailed description of the upgrade procedures for each specific component. Please note the warning and safety information indicated by the “” symbol.

The balance of this chapter reviews the computer's technical specifications and features.

## System Specifications

### Processor Options

- Mobile Intel Pentium 4 Processor-M
  - (478-pin) uFC-PGA package
  - ( $\mu$ 0.13) 0.13 Micron Process Technology,
  - 1.3/ 1.4/ 1.5/ 1.6/ 1.7 GHz

### Core Logic

- Intel 855GM + ICH4-M

### Structure

- PC2001 Compliant
- PCI 2.2 Compliant
- ACPI 2.0 Compliant

### Security

- Security (Kensington® Type) Lock Slot
- BIOS Password

### Memory

- Two 200-pin SODIMM sockets, supporting DDR modules
- Memory expandable up to 1GB (128/ 256/ 512 MB DDR modules)

### BIOS

- One 512KB Flash ROM
- Insyde BIOS, Plug and Play (1.0a)

### LCD

- 14.1" XGA Flat Panel TFT (1024\*768)

### Display

- Dynamic Video Memory Technology
- 128 bit 2D/3D Graphics Engine
- Motion Compensation for DVD Accelerator
- Fully DirectX 7/8 Compliant Graphics Engine
- Supports VESA DDCI, DDC2B and DDC 3.0 Specifications

### Storage

- One changeable 12.7mm(h) optical Drive
- Easy changeable 2.5" 9.5 mm (h) HDD
  - Supports Master Mode IDE
  - Supports LBA Mode
  - Supports PIO Mode 4
  - ATA-33/66/100

### PC Card

- One Type-II PCMCIA 3.3V/5V Socket

### Audio

- AC'97 2.2 Compliant
- Advanced Wavetable Synthesizer
- DirectSound™ 3D Accelerator
- Full-duplex
- Virtual AC3
- Built-In Microphone
- 2 Built-In Speakers

## Keyboard

- A4 Size Win 95 Keyboard (3mm travelling)
- Built-In TouchPad with Scrolling Function

## Interface

- Two USB 2.0 Ports
- One Mini- IEEE 1394 Port
- One External CRT Monitor Port
- One Headphone-Out Jack
- One Microphone-In Jack
- One S/P DIF Output Jack
- One TV-Out Jack
- One RJ-11 Jack for Plug & Play Fax/Modem
- One RJ-45 Jack for 10M/ 100M Fast Ethernet
- One DC-in jack

## Communication

- 56K Plug & Play Fax/Modem V.90/92 Compliant
- 10M/100M Fast Ethernet (IEEE 802.3 and 802.3u Standard Compliant)
- CMOS Camera with USB Interface
- INTEL PRO/Wireless LAN 2100 module with Mini-PCI interface
- Bluetooth 1.1 with MDC Interface (**optional**)

## Power Management

- Supports ACPI 2.0
- Soft Off by system Power Button
- Supports Suspend to disk
- Supports Suspend to RAM
- Supports Battery Low Suspend
- Supports Resume From Alarm Time
- Supports Resume From Modem Ring
- Supports Wake on LAN

## Power

- Full Range AC Adapter  
AC-Input 100~240V, 47~63Hz  
DC Output 20V, 3.25A (**65W**)
- 1st Smart Lithium-Ion (6 cells)
- 2nd Smart Lithium-Ion (12 cells) - **optional**

## Indicators

- LED Indicators (Power/Suspend, Battery, HDD/CD-ROM, Num Lock, Caps Lock, Scroll Lock, E-Mail, 802.11b & Bluetooth)

## Buttons

- E-Mail
- Internet Browser
- Power
- On/Off Switch for **optional** 802.11b & Bluetooth

## Introduction

---

### Environmental Spec

- Temperature
  - Operating: 5°C ~ 35°C
  - Non-Operating: -20°C ~ 60°C
- Relative Humidity
  - Operating: 20% ~ 80%
  - Non-Operating: 10% ~ 90%

### Physical Dimensions

- 312mm (w) \* 273mm (d) \* 27.5mm (h) Min

### Design Differences

This manual refers to the two notebook designs pictured below. The designs vary slightly in external design. Photographs used throughout this manual are of Design I.

### Weight

- 2.2kg without Battery Pack

### Optional

- 1st Smart Lithium-Ion (48Watt) Battery Pack
- 802.11b Module with Mini-PCI Interface
- Bluetooth 1.1 MDC Module
- 2.5" 12.5/12.7mm Height Hard Disk Drive
- 1st Smart Lithium-Ion (96Watt) Battery Pack

*Figure 1*  
**Design Differences**



Design I



Design II

## External Locator - Top View

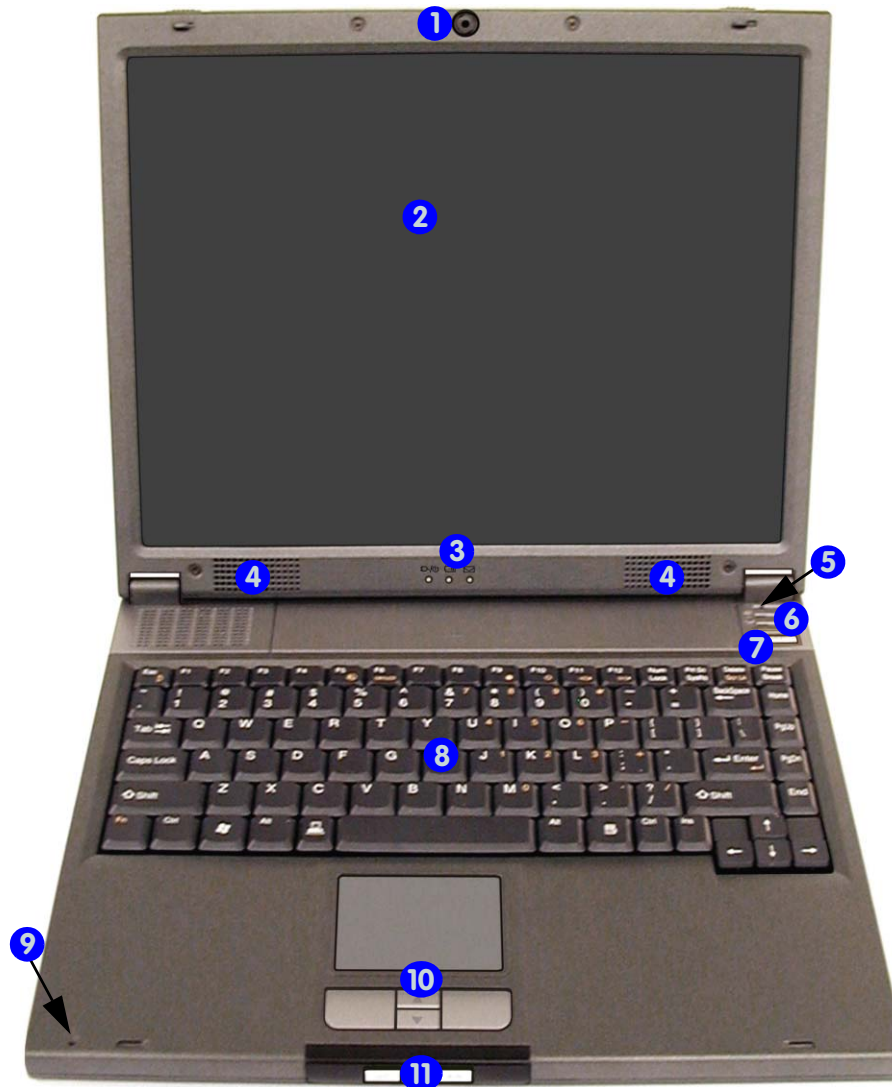

*Figure 2*  
**Top View**

1. Built-In CMOS Camera
2. LCD
3. LED Power & Communication Indicators
4. Speakers
5. Close Cover Switch
6. LED Status Indicators
7. Power Button
8. Keyboard
9. Built-In Microphone
10. TouchPad and Buttons
11. Hot-Key Buttons



## Introduction

*Figure 3*  
**Front View**

1. LCD Latches
2. Hot-Key Buttons

## External Locator - Front & Left Side Views



*Figure 4*  
**Left Side View**

1. Vent
2. External Monitor (CRT) Port
3. S-Video-Out Port
4. RJ-11 Phone Jack
5. RJ-45 LAN Jack
6. 2 \* USB 2.0 Ports
7. IEEE 1394 Port
8. PC Card Slot Eject Button
9. PC Card Slot

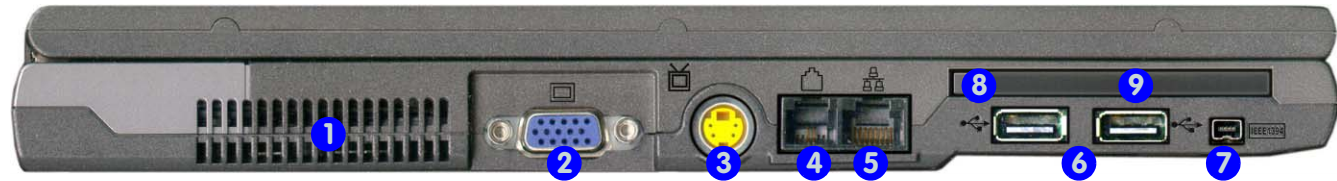

## External Locator - Right Side & Rear Views



*Figure 5*  
**Right Side View**

1. Microphone-In Jack
2. Headphone-Out Jack
3. S/P DIF Out Port
4. CD Device Bay
5. DC-In Jack



*Figure 6*  
**Rear View**

1. Security Lock Slot
2. Vent

## External Locator - Bottom View

Figure 7  
Bottom View

1. Vent/Fan Intakes
2. Battery
3. CPU Cover
4. RAM & Modem Cover
5. CD Device Removal Cover
6. Hard Disk & WLAN Cover

**Note:** The RAM cards are located under the RAM & Modem Cover while the optional Wireless LAN module is located under the Hard Disk Cover.

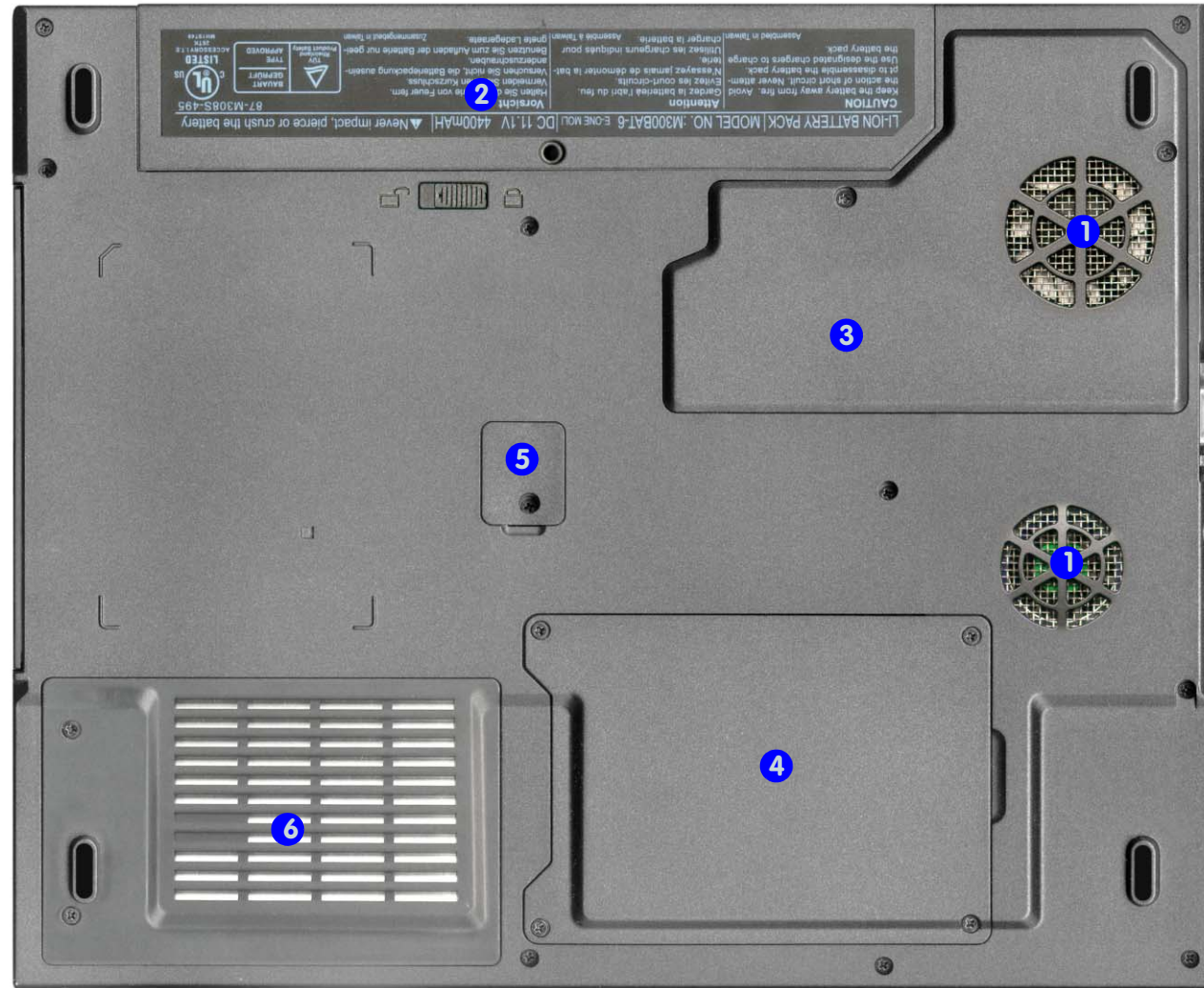

## Mainboard Overview - Top (Key Parts)

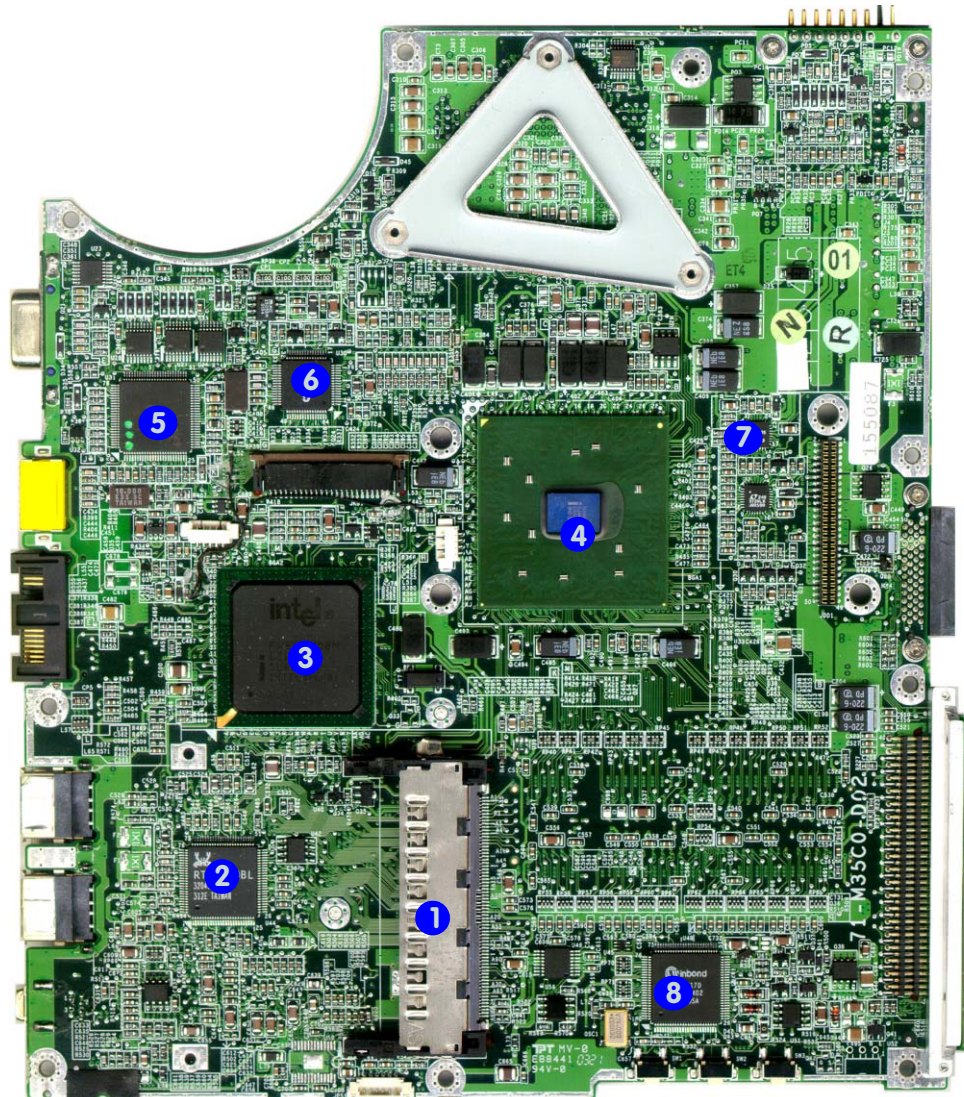

*Figure 8*  
**Mainboard Top  
Key Parts**

1. PC Card Assembly
2. LAN Controller  
RTL8100BL
3. Southbridge -  
Intel 82801DB
4. Northbridge -  
Intel 82852GM
5. H8 Keyboard  
Controller
6. TV-Out Controller
7. V-Core Power IC
8. Super I/O  
Winbond 83517

## Introduction

# Mainboard Overview - Bottom (Key Parts)

*Figure 9*  
**Mainboard Bottom  
Key Parts**

1. Memory Sockets  
(no memory installed)
2. CPU Socket (no CPU installed)
3. Clock Generator
4. BIOS EEPROM
5. LAN Transformer 1410
6. CardBus ENE 1410
7. 1394 PHY TSB41LV01
8. ALC202 - Audio Codec
9. Audio Amplifier

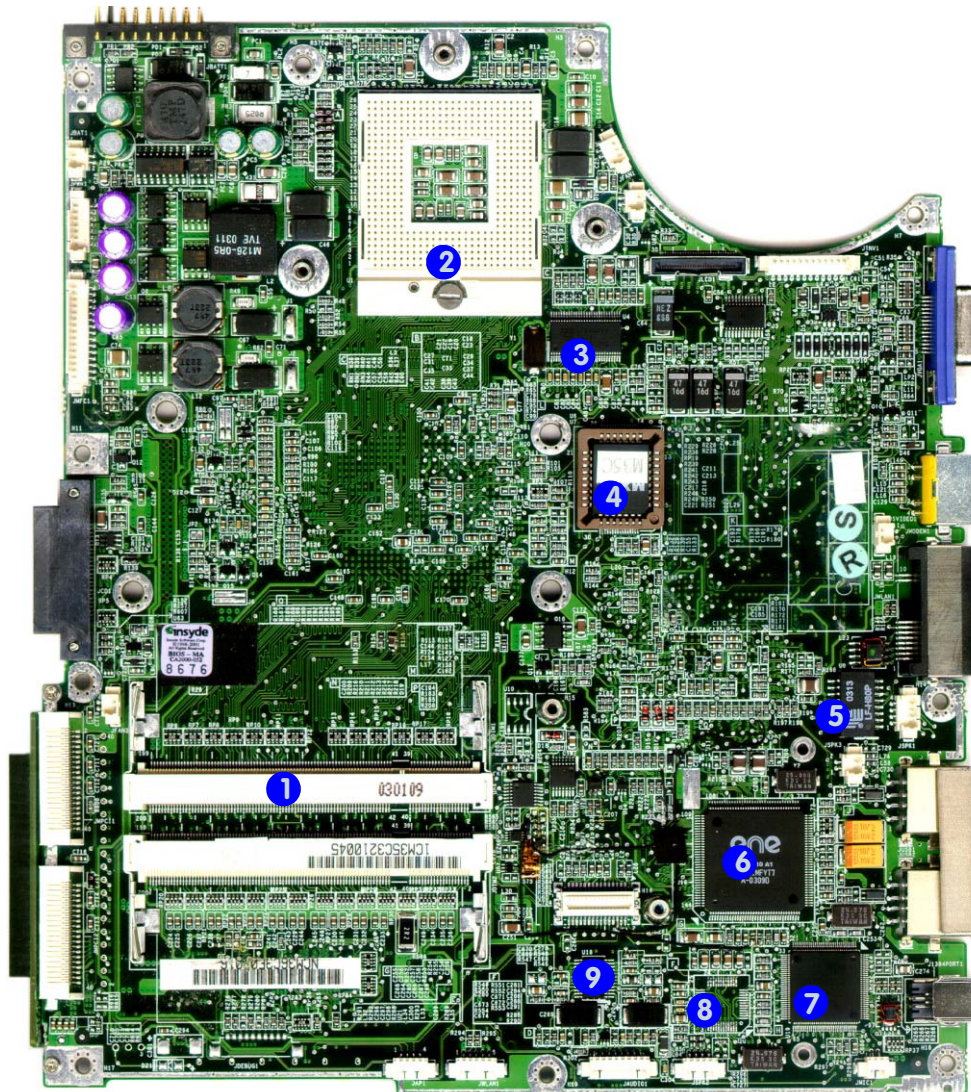

## Mainboard Overview - Top (Connectors)

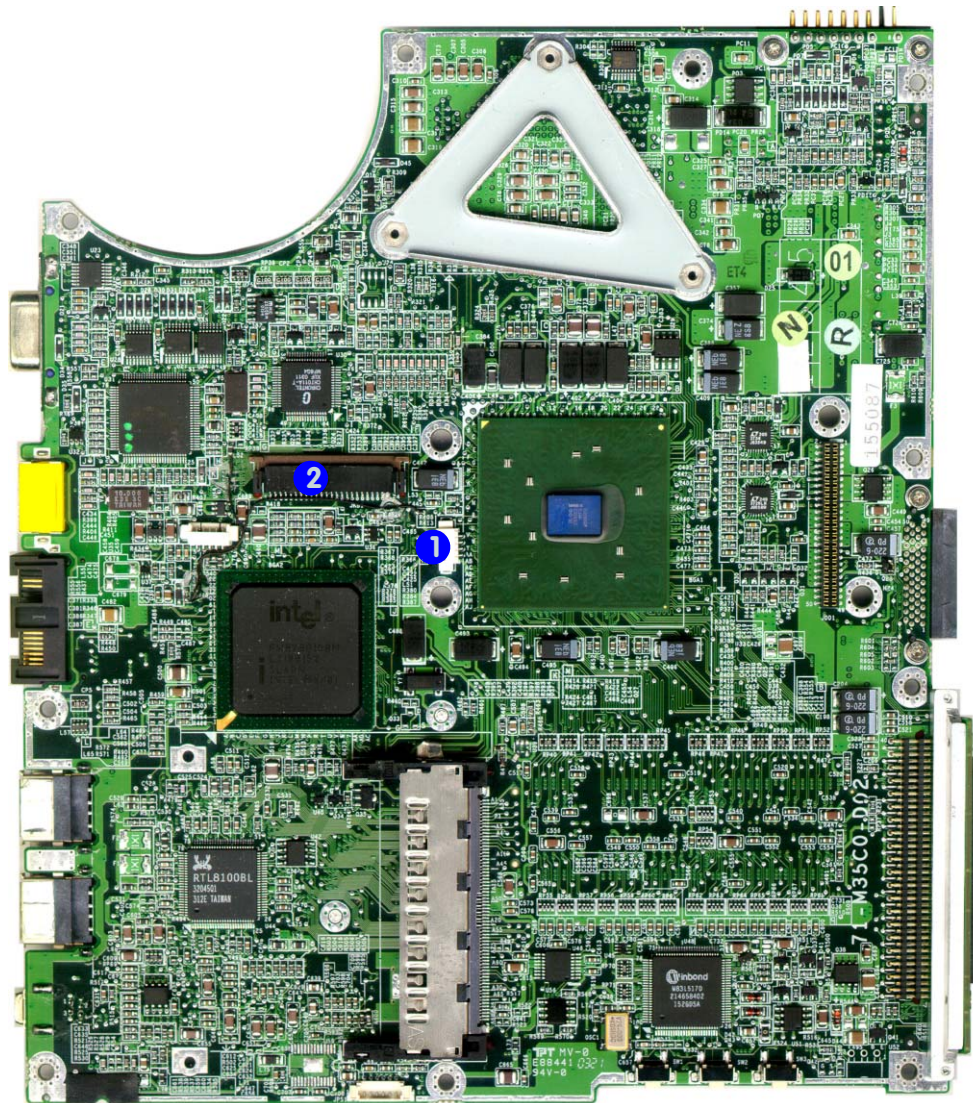

*Figure 10*  
**Mainboard Top  
Connectors**

1. TouchPad Cable Connector (JTP1)
2. Keyboard Connector (JKB1)

## Introduction

*Figure 11*  
**Mainboard Bottom  
Connectors**

## Mainboard Overview - Bottom (Connectors)

1. Battery Connector (JBATT1)
2. RTC (JBAT1)
3. Power Cable Connector (JPWR1)
4. Multi-function Board Cable Connector (JMFC1)
5. CD-ROM Connector (JCD1)
6. Hard Disk Connector (JHDD1)
7. Wireless LAN Cable Connector (JWLAN1)
8. Audio Board Cable Connector (JAUDIO1)
9. Int. MIC (JMIC1)
10. 1394 Connector
11. USB Connector (JUSB1 & JUSB2)
12. Int. Speaker Cable Connector (JSPK1)
13. LAN Connector (JMLAN1)
14. Modem Cable Connector (JMODEM1)
15. TV-Out Connector (JSVIDEO1)
16. VGA-Out Connector (JVGA1)
17. Inverter Connector (JINV1)
18. LCD (LVDS) Connector (JLCD1)
19. Fan Cable Connector (JFAN1 & JFAN2)
20. Modem Connector (JMDC1)

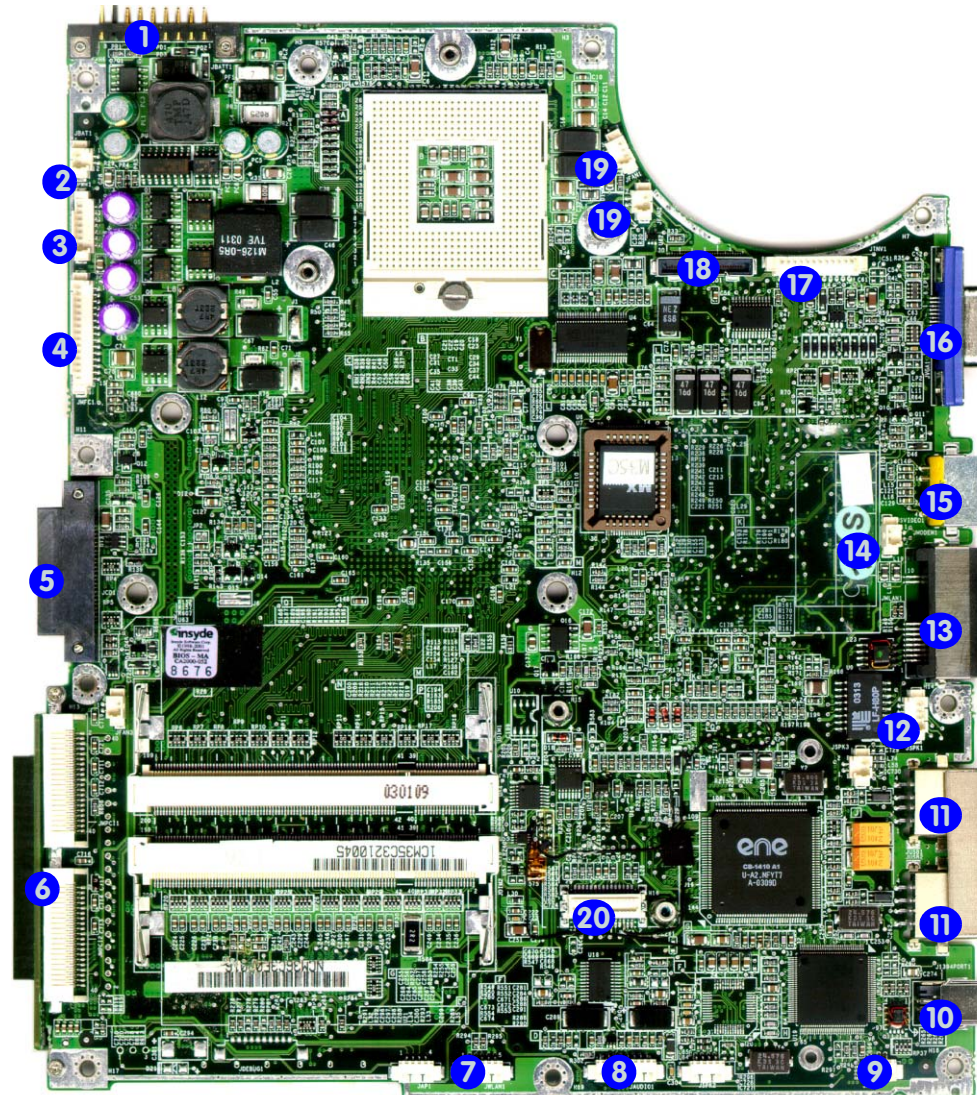

# 2: Disassembly



## Overview

This chapter provides step-by-step instructions for disassembling the *M350C/M360C* series notebook's parts and sub-systems. When it comes to reassembly, reverse the procedures (unless otherwise indicated).

We suggest you completely review any procedure before you take the computer apart.

Procedures such as upgrading/replacing the RAM, CD device and hard disk are included in the User's Manual but are repeated here for your convenience.

To make the disassembly process easier each section may have a box in the page margin. Information contained under the figure # will give a synopsis of the sequence of procedures involved in the disassembly procedure. A box with a  lists the relevant parts you will have after the disassembly process is complete. **Note:** The parts listed will be for the disassembly procedure listed ONLY, and not any previous disassembly step(s) required. Refer to the part list for the previous disassembly procedure. The amount of screws you should be left with will be listed here also.

A box with a  will also provide any possible helpful information. A box with a  contains warnings.

An example of these types of boxes are shown in the sidebar.

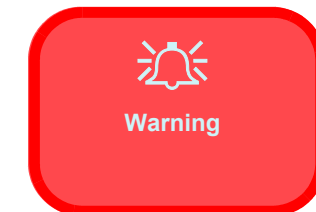
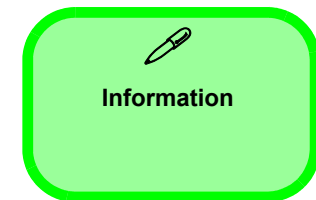



## Disassembly

---

**NOTE:** All disassembly procedures assume that the system is turned **OFF**, and disconnected from any power supply (the battery is removed too).

### Maintenance Tools

The following tools are recommended when working on the notebook PC:

- M3 Philips-head screwdriver
- M2.5 Philips-head screwdriver (magnetized)
- M2 Philips-head screwdriver
- Small flat-head screwdriver
- Pair of needle-nose pliers
- Anti-static wrist-strap

### Connections

Connections within the computer are one of four types:

Locking collar sockets for ribbon connectors	To release these connectors, use a small flat-head screwdriver to gently pry the locking collar away from its base. When replacing the connection, make sure the connector is oriented in the same way. The pin1 side is usually not indicated.
Pressure sockets for multi-wire connectors	To release this connector type, grasp it at its head and gently rock it from side to side as you pull it out. Do not pull on the wires themselves. When replacing the connection, do not try to force it. The socket only fits one way.
Pressure sockets for ribbon connectors	To release these connectors, use a small pair of needle-nose pliers to gently lift the connector away from its socket. When replacing the connection, make sure the connector is oriented in the same way. The pin1 side is usually not indicated.
Board-to-board or multi-pin sockets	To separate the boards, gently rock them from side to side as you pull them apart. If the connection is very tight, use a small flat-head screwdriver - use just enough force to start.

## Maintenance Precautions

The following precautions are a reminder. To avoid personal injury or damage to the computer while performing a removal and/or replacement job, take the following precautions:

1. **Don't drop it.** Perform your repairs and/or upgrades on a stable surface. If the computer falls, the case and other components could be damaged.
2. **Don't overheat it.** Note the proximity of any heating elements. Keep the computer out of direct sunlight.
3. **Avoid interference.** Note the proximity of any high capacity transformers, electric motors, and other strong magnetic fields. These can hinder proper performance and damage components and/or data. You should also monitor the position of magnetized tools (i.e. screwdrivers).
4. **Keep it dry.** This is an electrical appliance. If water or any other liquid gets into it, the computer could be badly damaged.
5. **Be careful with power.** Avoid accidental shocks, discharges or explosions.
  - Before removing or servicing any part from the computer, turn the computer off and detach any power supplies.
  - When you want to unplug the power cord or any cable/wire, be sure to disconnect it by the plug head. Do not pull on the wire.
6. **Peripherals** – Turn off and detach any peripherals.
7. **Beware of static discharge.** ICs, such as the CPU and main support chips, are vulnerable to static electricity. Before handling any part in the computer, discharge any static electricity inside the computer. When handling a printed circuit board, do not use gloves or other materials which allow static electricity buildup. We suggest that you use an anti-static wrist strap instead.
8. **Beware of corrosion.** As you perform your job, avoid touching any connector leads. Even the cleanest hands produce oils which can attract corrosive elements.
9. **Keep your work environment clean.** Tobacco smoke, dust or other air-borne particulate matter is often attracted to charged surfaces, reducing performance.
10. **Keep track of the components.** When removing or replacing any part, be careful not to leave small parts, such as screws, loose inside the computer.

## Cleaning

Do not apply cleaner directly to the computer, use a soft clean cloth.

Do not use volatile (petroleum distillates) or abrasive cleaners on any part of the computer.



### Power Safety Warning

Before you undertake any upgrade procedures, make sure that you have turned off the power, and disconnected all peripherals and cables (including telephone lines). It is advisable to also remove your battery in order to prevent accidentally turning the machine on.

### Disassembly Steps

The following table lists the disassembly steps, and on which page to find the related information. **PLEASE PERFORM THE DISASSEMBLY STEPS IN THE ORDER INDICATED.**

#### To remove the Battery:

1. Remove the battery [page 2 - 7](#)

#### To remove the HDD & WLAN:

1. Remove the battery [page 2 - 7](#)
2. Remove the HDD & WLAN [page 2 - 8](#)

#### To remove the System Memory:

1. Remove the battery [page 2 - 7](#)
2. Remove the system memory [page 2 - 10](#)

#### To remove the CD Device:

1. Remove the battery [page 2 - 7](#)
2. Remove the CD device [page 2 - 12](#)

#### To remove the Modem:

1. Remove the battery [page 2 - 7](#)
2. Remove the modem [page 2 - 13](#)

#### To remove the Processor:

1. Remove the battery [page 2 - 7](#)
2. Remove the processor [page 2 - 14](#)

#### To remove the Keyboard:

1. Remove the battery [page 2 - 7](#)
2. Remove the keyboard [page 2 - 16](#)

#### To remove the Bottom Case:

1. Remove the battery [page 2 - 7](#)
2. Remove the HDD & WLAN [page 2 - 8](#)
3. Remove the system memory [page 2 - 10](#)
4. Remove the CD device [page 2 - 12](#)
5. Remove the processor [page 2 - 14](#)
6. Remove the bottom case [page 2 - 17](#)

#### To remove the Audioboard:

1. Remove the battery [page 2 - 7](#)
2. Remove the HDD & WLAN [page 2 - 8](#)
3. Remove the CD device [page 2 - 12](#)
4. Remove the processor [page 2 - 14](#)
5. Remove the bottom case [page 2 - 17](#)
6. Remove the audioboard [page 2 - 18](#)

**To remove the Multi-function board:**

1. Remove the battery [page 2 - 7](#)
2. Remove the HDD & WLAN [page 2 - 8](#)
3. Remove the CD device [page 2 - 12](#)
4. Remove the processor [page 2 - 14](#)
5. Remove the bottom case [page 2 - 17](#)
6. Remove the multi-function board [page 2 - 19](#)

**To remove the Mainboard:**

1. Remove the battery [page 2 - 7](#)
2. Remove the HDD & WLAN [page 2 - 8](#)
3. Remove the system memory [page 2 - 10](#)
4. Remove the CD device [page 2 - 12](#)
5. Remove the modem [page 2 - 13](#)
6. Remove the processor [page 2 - 14](#)
7. Remove the keyboard [page 2 - 16](#)
8. Remove the bottom case [page 2 - 17](#)
9. Remove the audioboard [page 2 - 18](#)
10. Remove the multi-function board [page 2 - 19](#)
11. Remove the mainboard [page 2 - 20](#)

**To remove the TouchPad & Click Board:**

1. Remove the battery [page 2 - 7](#)
2. Remove the HDD & WLAN [page 2 - 8](#)
3. Remove the system memory [page 2 - 10](#)
4. Remove the CD device [page 2 - 12](#)
5. Remove the modem [page 2 - 13](#)
6. Remove the processor [page 2 - 14](#)
7. Remove the keyboard [page 2 - 16](#)
8. Remove the bottom case [page 2 - 17](#)
9. Remove the audioboard [page 2 - 18](#)
10. Remove the multi-function board [page 2 - 19](#)
11. Remove the mainboard [page 2 - 20](#)
12. Remove the touchpad & click board [page 2 - 21](#)

**To remove the Inverter:**

1. Remove the battery [page 2 - 7](#)
2. Remove the inverter [page 2 - 22](#)

**To remove the Speakers:**

1. Remove the battery [page 2 - 7](#)
2. Remove the HDD & WLAN [page 2 - 8](#)
3. Remove the CD device [page 2 - 12](#)
4. Remove the processor [page 2 - 14](#)
5. Remove the bottom case [page 2 - 17](#)
6. Remove the multi-function board [page 2 - 19](#)
7. Remove the mainboard [page 2 - 20](#)
8. Remove the inverter [page 2 - 22](#)
9. Remove the speakers [page 2 - 23](#)

## Disassembly

---

### To remove the LCD Panel:

1. Remove the battery *page 2 - 7*
2. Remove the HDD & WLAN *page 2 - 8*
3. Remove the CD device *page 2 - 12*
4. Remove the processor *page 2 - 14*
5. Remove the bottom case *page 2 - 17*
6. Remove the multi-function board *page 2 - 19*
7. Remove the inverter *page 2 - 22*
8. Remove the LCD panel *page 2 - 24*

### To remove the PC Camera:

1. Remove the battery *page 2 - 7*
2. Remove the inverter *page 2 - 22*
3. Remove the PC Camera *page 2 - 24*

# Removing the Battery

1. Turn the computer **off**, and turn it over.
2. Locate the battery release latch **1** (*Figure 1a*).
3. Latch **1** should slide to the left, and you will need to hold it in place (*Figure 1b*).
4. Slide the Battery **2** out (*Figure 1c*).

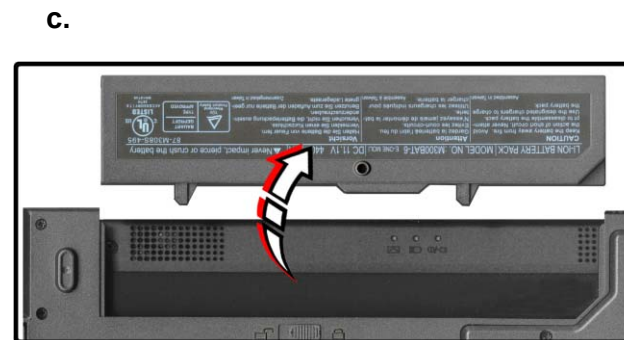
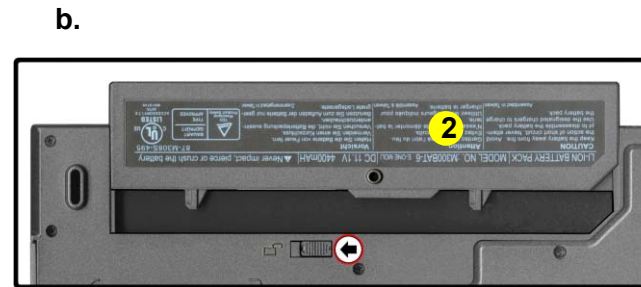
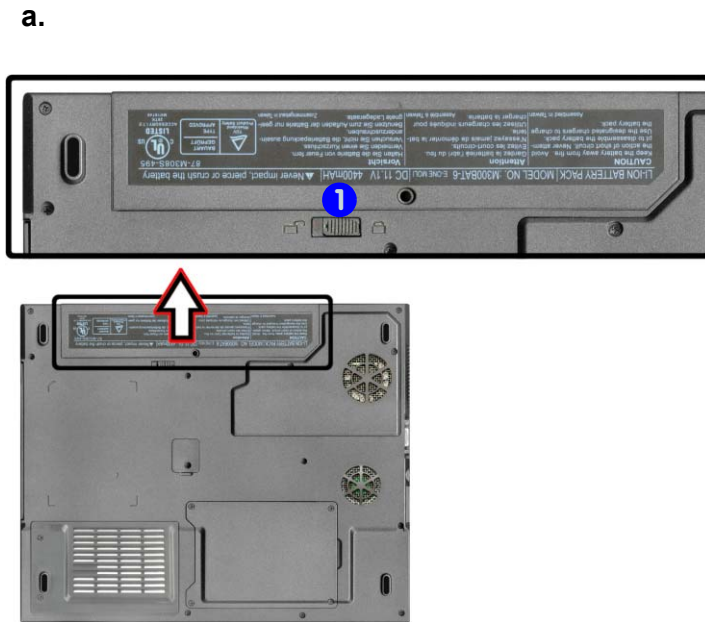
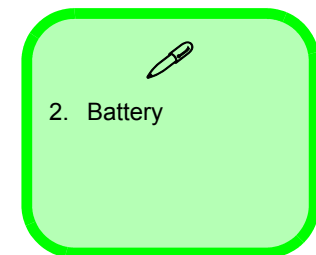

Figure 1  
Battery Removal

- a. Locate the battery release latch.
- b. Slide the latch to the left and hold.
- c. Slide the battery out.



## Removing the Hard Disk Drive and Wireless LAN

The hard disk drive is mounted in a removable case and can be taken out to accommodate other 2.5" IDE hard disk drives with a height of 9.5mm (h). Follow your operating system's installation instructions, and install all necessary drivers and utilities (as outlined in **Chapter 4 of the User's Manual**) when setting up a new hard disk.

*Figure 2*  
**HDD Assembly & Wireless LAN Removal**

### Hard Disk Upgrade Process

- a. Remove the 2 screws.
  - b. Remove the cover.
  - c. Disconnect the cables from the Wireless LAN module.
1. Turn **off** the computer, remove the battery ([page 2 - 7](#)) and turn it over.
  2. Remove screws **1** & **2** ([Figure 2a](#)), and remove the hard disk cover **3**.



#### HDD System Warning

New HDD's are blank. Before you begin make sure:

You have backed up any data you want to keep from your old HDD.

You have all the CD-ROMs and FDDs required to install your operating system and programs.

If you have access to the internet, download the latest application and hardware driver updates for the operating system you plan to install. Copy these to a removable medium.



- 3. Hard Disk Cover
- 2 Screws

a.

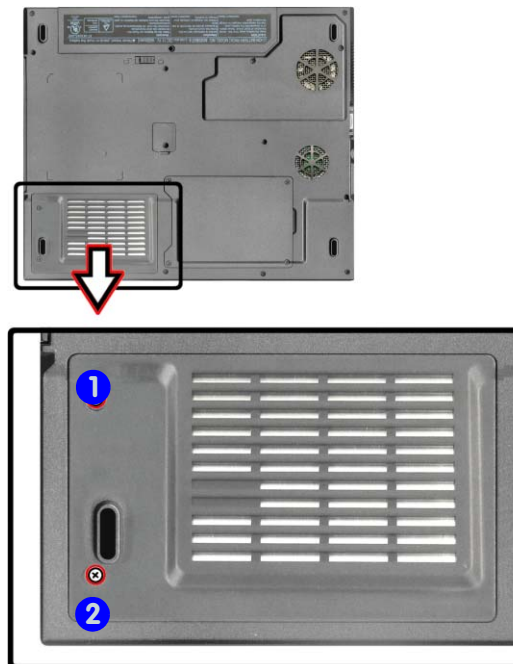

b.

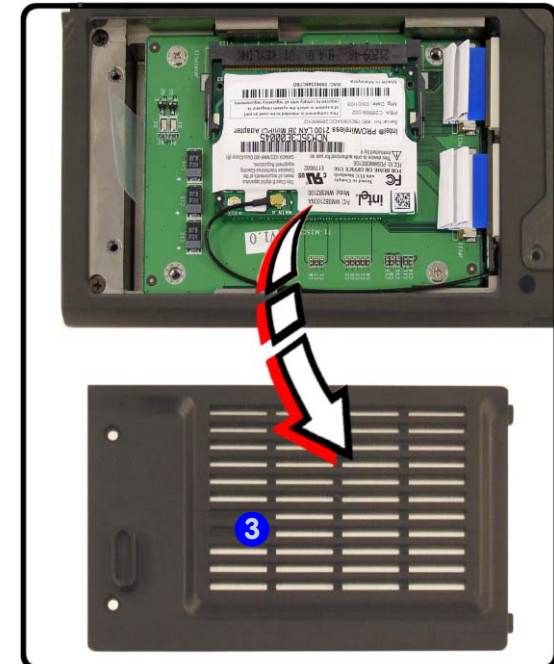

3. Carefully disconnect the Wireless LAN antenna cable ①, and slide the hard disk assembly in the direction of the arrow ② (Figure 3a).
4. Carefully lift the hard disk assembly up out off the computer (the cables ③ & ④ will be released as you lift out the hard disk and Mini-PCI board).
5. Remove screws ⑤ - ⑧ in order to separate the Mini-PCI board ⑩ from the hard disk ⑨ (Figure 3d).
6. Gently pull the release latches ⑪, and slide the Wireless LAN module as indicated by the arrow ⑫ (Figure 3e).
7. The Wireless LAN module ⑬ will pop-up, and you can remove it (Figure 3d).
8. Reverse the process to install a new hard disk (pay careful attention to the orientation of the disk in the case) or replace the Wireless LAN module.

Figure 3  
HDD Assembly &  
Wireless LAN  
Removal (Cont.)

- a. Disconnect antenna cable and slide out the HDD assembly.
- b. Lift the HDD assembly out of the bay.
- c. Remove the screws.
- d. Separate the Mini PCI board and HDD.
- e. Pull the release latches.
- f. Remove the Wireless LAN module from the Mini PCI board.

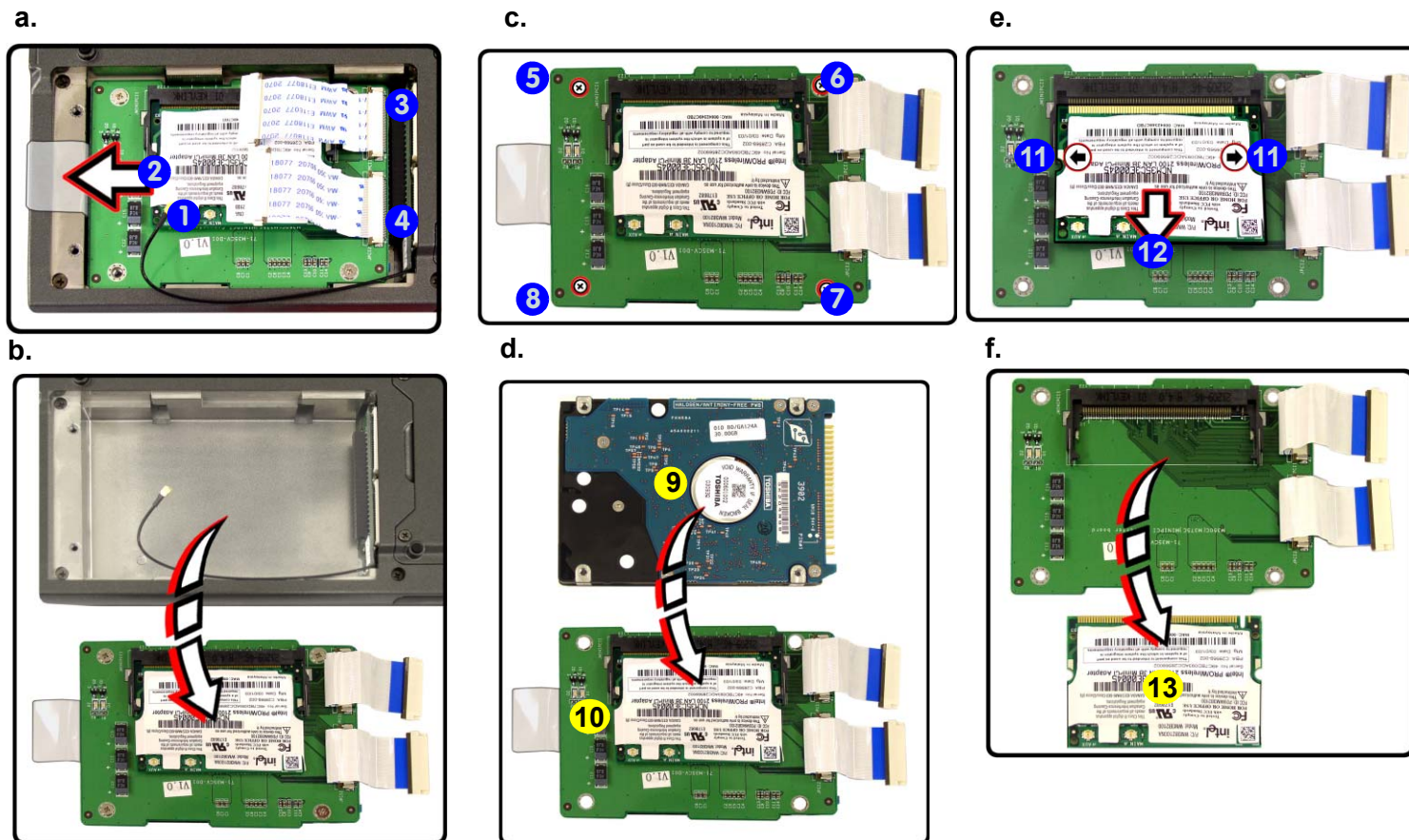

✍

9. Hard Disk  
10. Mini PCI Board  
13. Wireless LAN Module

- 4 Screws



# Removing the System Memory (RAM)

The computer has two memory sockets for 200 pin Small Outline Dual In-line Memory Modules (SO-DIMM) supporting DDR 200/266/333MHz. The main memory can be expanded up to 1024MB. The SO-DIMM modules supported are 128Mb, 256Mb, and 512Mb. The total memory size is automatically detected by the POST routine once you turn on your computer.

*Figure 4*  
**Memory Socket Cover Removal**

- a. Remove the screws.
- b. Carefully lift the cover off the computer.

### Memory Upgrade Process

1. Turn **off** the computer, remove the battery ([page 2 - 7](#)) and turn it over.
2. Remove screws **1** - **4** ([Figure 4a](#)) from the memory socket cover.
3. Carefully lift up the memory socket cover **5** off the computer ([Figure 4b](#)).
4. If there is a module currently installed which needs to be upgraded/replaced then remove it.

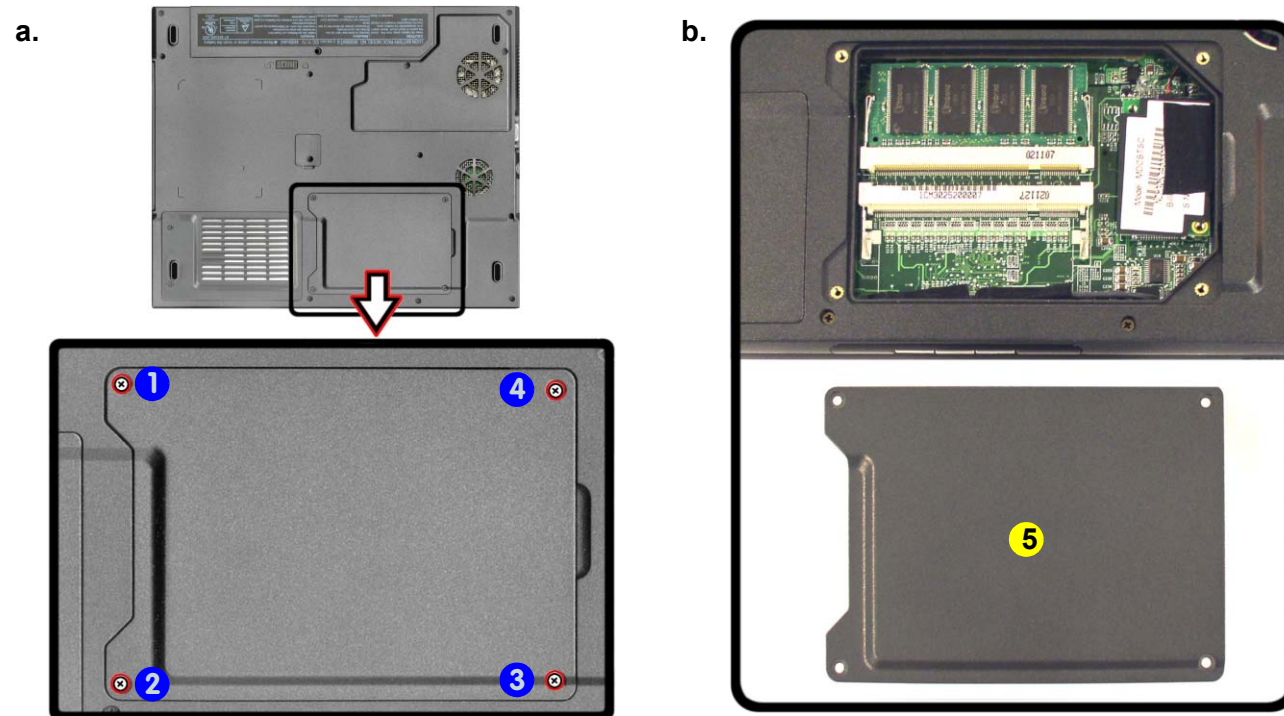

5. Socket Cover

- 4 Screws

- Gently pull the two release latches (1 & 2) on the sides of the memory socket toward the sides of the computer.

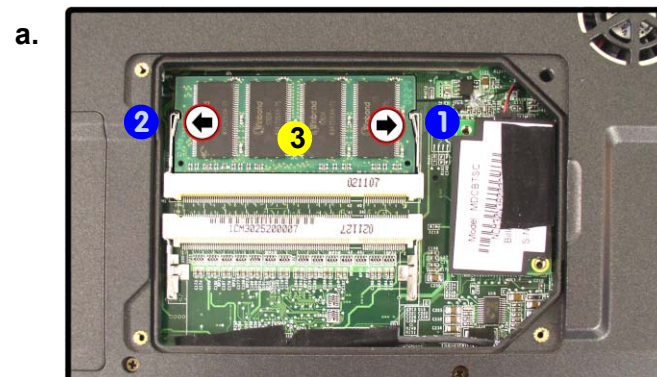

- The module 3 (Figure 5b) will pop-up, and you can remove it.
- Repeat the process for the second module if necessary.
- Insert a new module holding it at about a 30° angle and fit the connectors firmly into the memory slot.
- The module will only fit one way as defined by its pin alignment. Make sure the module is seated as far into the slot as it will go. DO NOT FORCE IT; it should fit without much pressure.

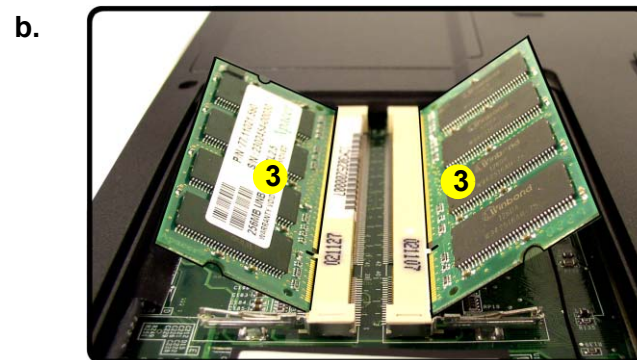

- Press the module down towards the mainboard until the slot levers click into place to secure the module.
- Replace the memory socket cover and the 4 screws (see page 2 - 10).
- Restart the computer.
- The BIOS will register the new memory configuration as it starts up.

*Figure 5*  
**Removing/  
Installing a RAM  
Module**

- Pull the release latches.
- Remove the module.



**Contact Warning**

Be careful not to touch the metal pins on the module's connecting edge. Even the cleanest hands have oils which can attract particles, and degrade the module's performance.



3. RAM Module

## Disassembly

### Removing the CD Device

Figure 6

#### CD Device Removal

- Remove the screws.
- Carefully lift the cover off the computer.
- Push the CD device out off the computer at point 2.
- Remove the CD device.

- Turn **off** the computer, remove the battery ([page 2 - 7](#)) and turn it over.
- Remove screw **1** ([Figure 6a](#)) and carefully lift up the CD device removal cover **2** ([Figure 6b](#)).
- Use a screwdriver to carefully push the CD device assembly **3** out of the computer at point **4** ([Figure 6c](#)).
- Insert the new device and carefully slide it into the computer (the device only fits one way. **DO NOT FORCE IT**; The screw holes should line up).
- Replace the CD device removal cover and the screw.
- Restart the computer to allow it to automatically detect the new device.

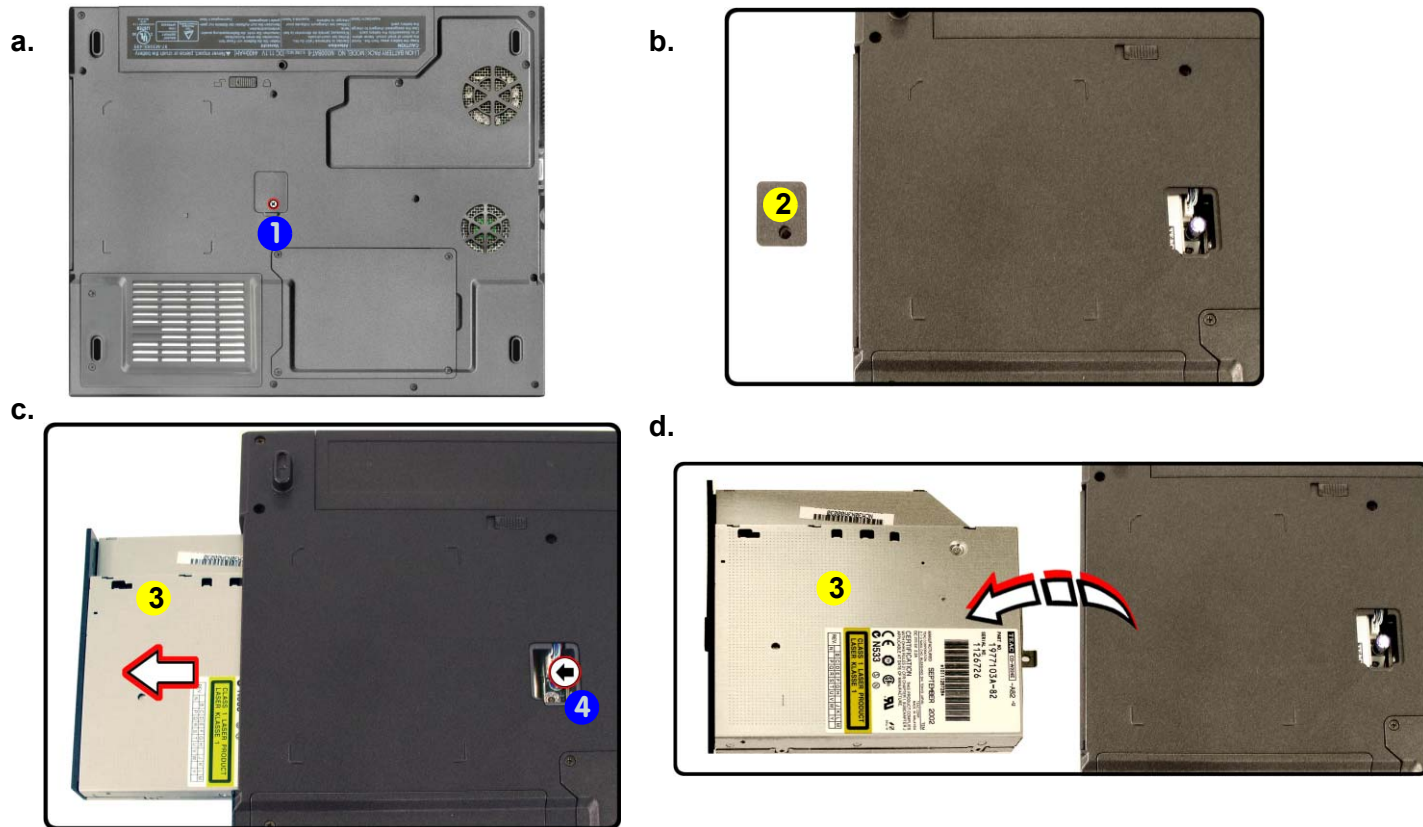

- 2. CD Device Removal Cover
- 3. CD Device
- 1 Screw

## Removing the Modem

1. Turn **off** the computer, remove the battery ([page 2 - 7](#)) and turn it over.
2. Remove screws **1** - **4** from the memory socket cover ([Figure 7a](#)).
3. Carefully lift up the memory socket cover **5** off the computer.
4. Remove screws **6** - **7** ([Figure 7b](#)), and carefully disconnect cables **8** - **9** and connector **10**.
5. Lift the modem **11** ([Figure 7d](#)) off the computer.

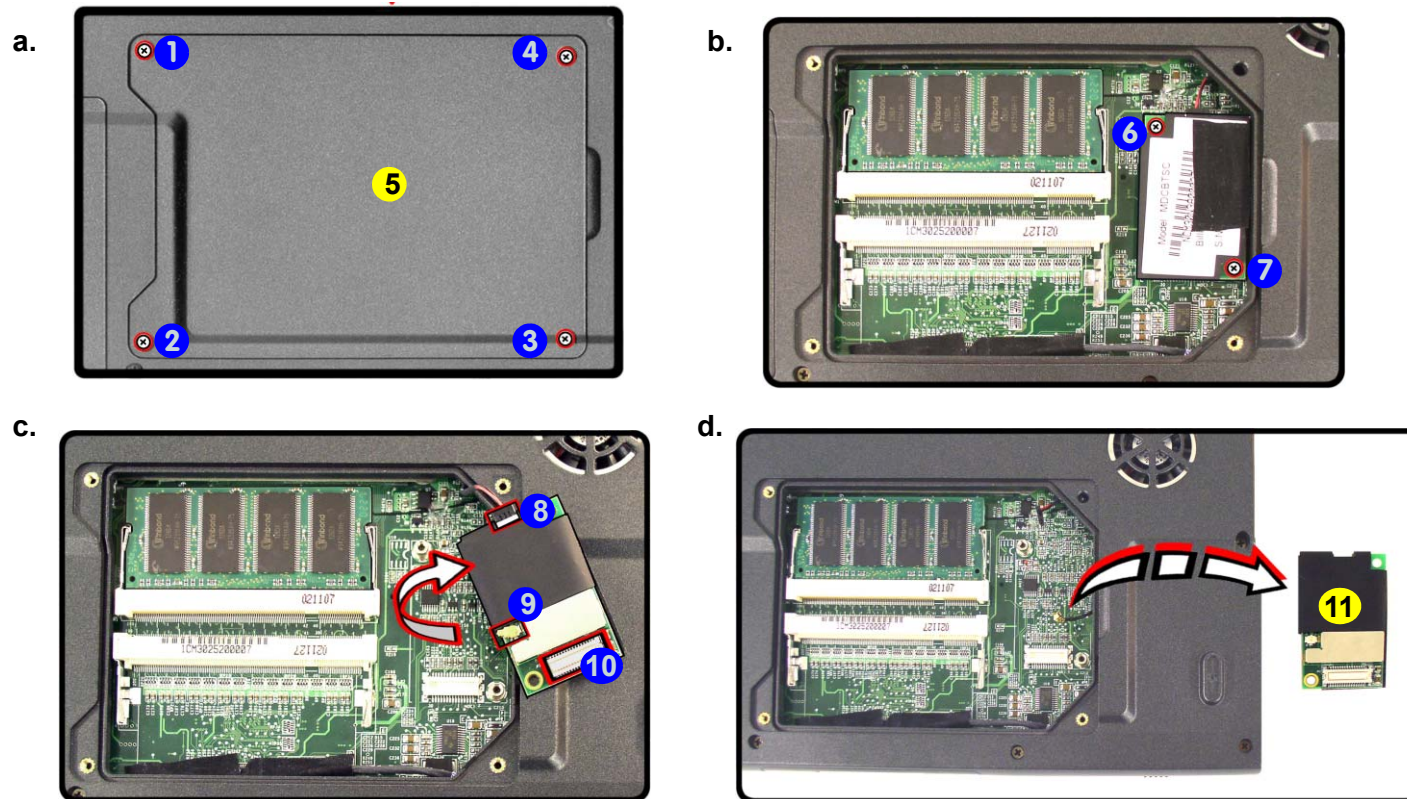

*Figure 7*  
**Modem Removal**

- a. Remove the screws.
- b. Lift the cover off the computer.
- c. Carefully disconnect the cables and connector.
- d. Remove the modem.

5. Socket Cover  
11. Modem

- 6 Screws

## Removing the Processor

Figure 8

### Processor Removal

- a. Remove the screws.
- b. Carefully lift the cover off the computer.
- c. Remove the screws in the order indicated.
- d. Remove the heat sink.

1. Turn off the computer, remove the battery (page 2 - 7) and turn it over.
2. Remove screws 1 - 2 from the CPU cover.
3. Carefully lift up the CPU cover 3 off the computer.
4. Remove screws 4 - 6 (Figure 8c) from the heat sink.
5. Carefully lift up the heat sink 7 (Figure 8d) off the computer.

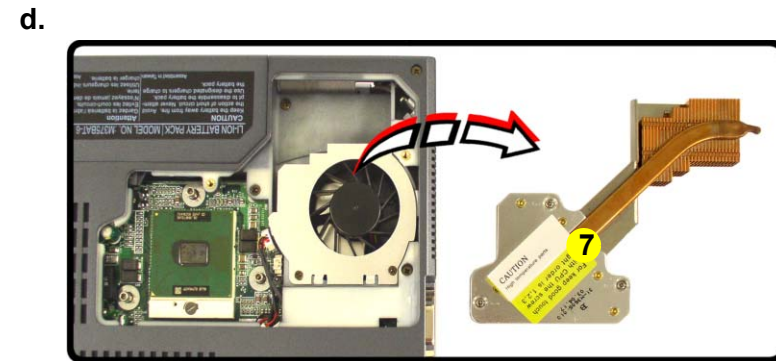
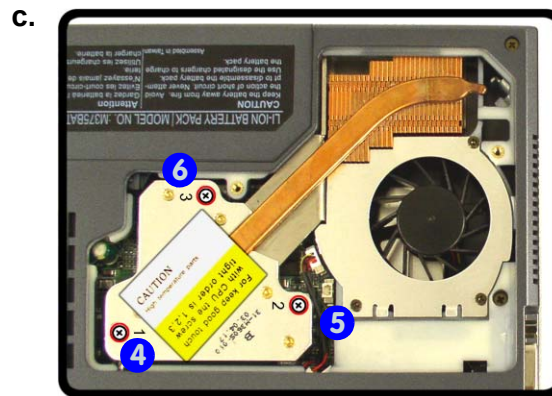
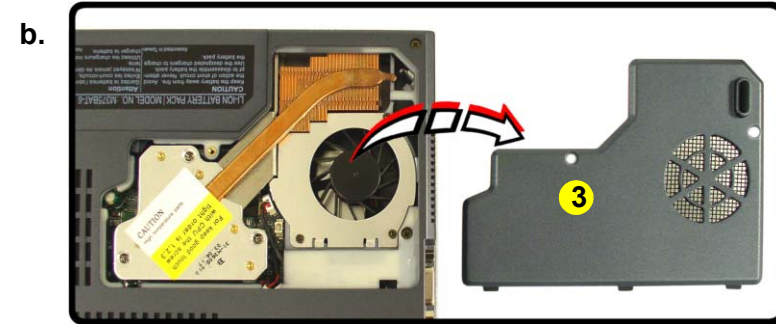
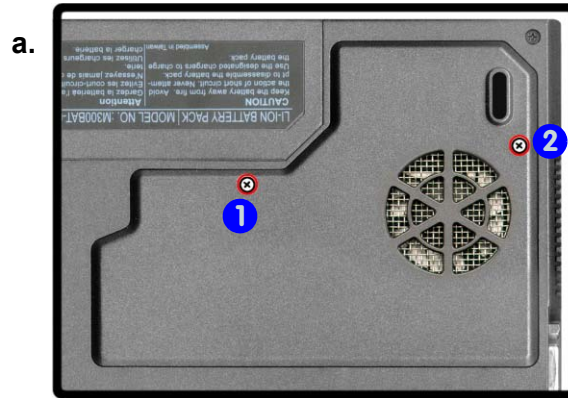



3. CPU Cover  
7. Heat Sink

- 5 Screws

6. Turn the release latch **1** towards the unlock symbol , to unlock the CPU (*Figure 9a*).
7. Carefully (it may be hot) lift the CPU **2** up out of the socket (*Figure 9b*).
8. When re-inserting the CPU, pay careful attention to the pin alignment, it will fit only one way (don't force it!).

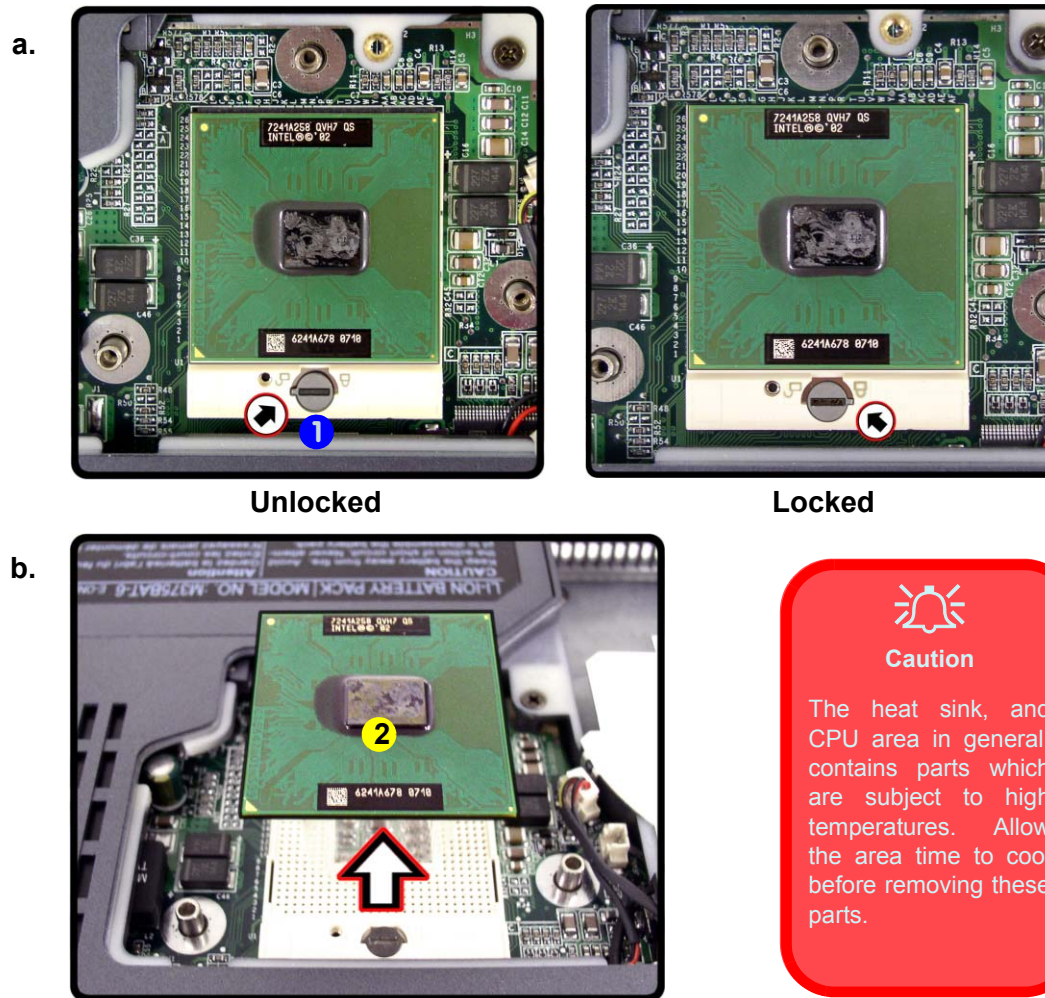

*Figure 9*  
**Processor Removal**  
**(cont'd)**

- a. Turn the release latch to unlock the CPU.
- b. Lift the CPU out of the socket.

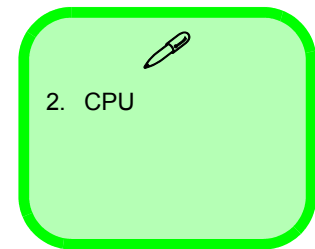

## Disassembly

Figure 10  
Keyboard Removal

- Press the latches to elevate the keyboard.
- Disconnect the keyboard cable from the locking collar socket.
- Remove the keyboard.

## Removing the Keyboard

- Turn **off** the computer, remove the battery ([page 2 - 7](#)).
- Press the **three** keyboard latches at the top of the keyboard to elevate the keyboard from its normal position (you may need to use a small screwdriver to do this).
- Carefully lift the keyboard up and out, being careful not to bend the keyboard ribbon cable **1** ([Figure 10b](#)).
- Disconnect the keyboard ribbon cable from the locking collar socket **2** ([Figure 10b](#)) and lift the keyboard **3** up out of the computer.

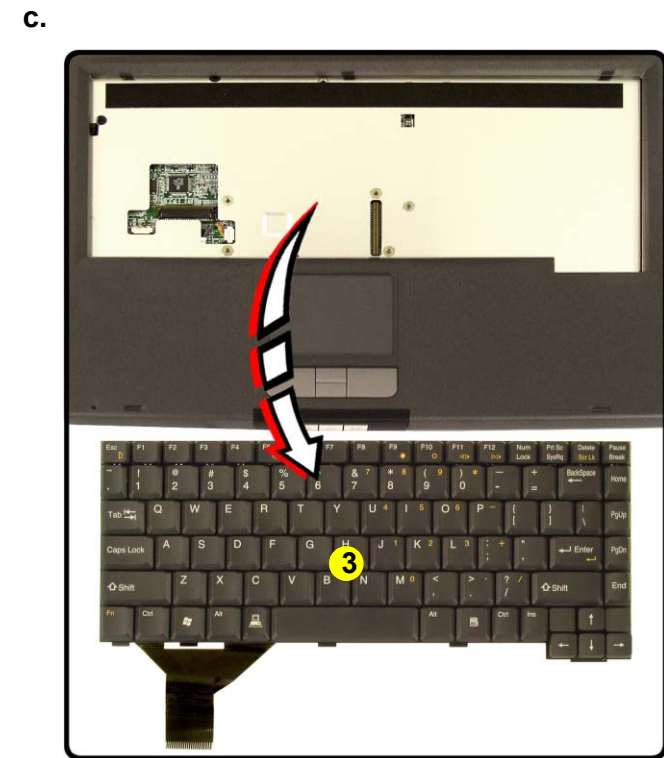
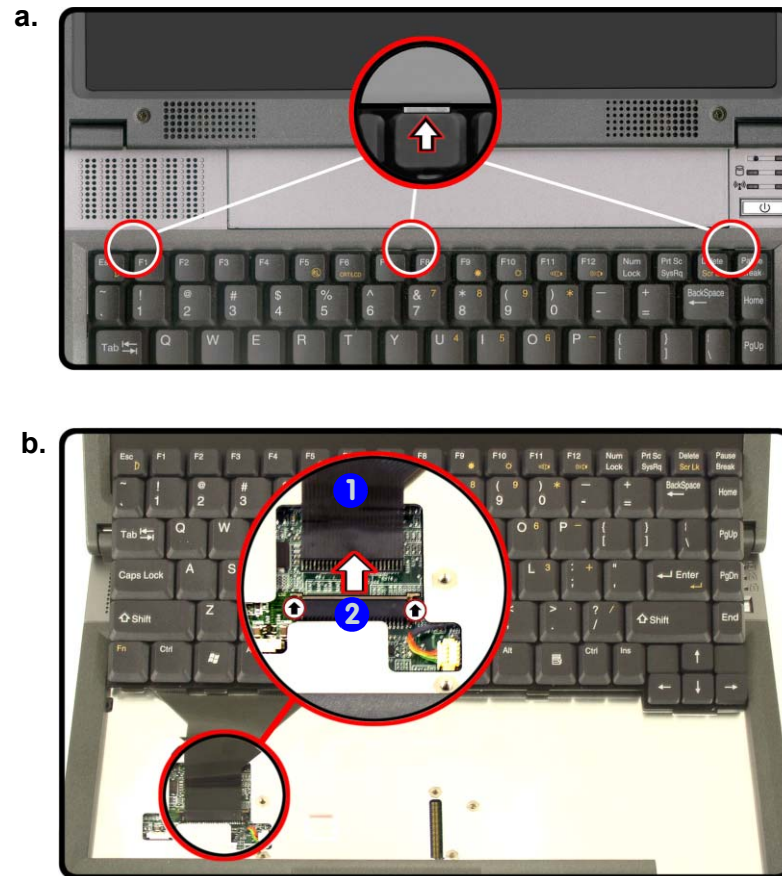

3. Keyboard

## Removing the Bottom Case

1. Turn **off** the computer, remove the battery ([page 2 - 7](#)), hard disk ([page 2 - 8](#)), RAM ([page 2 - 10](#)), CD Device ([page 2 - 12](#)), and CPU ([page 2 - 14](#)).
2. Remove screws **1** - **13** ([Figure 11a](#)) from the bottom of the computer.
3. Remove screws **14** - **17** from the fan shield cover and disconnect cables **18** & **19** ([Figure 11b](#)).
4. Lift the fan shield cover **20** out of the computer ([Figure 11c](#)), and remove screws **21** - **22** ([Figure 11d](#)).
5. Carefully lift the bottom case **24** off the LCD and top case assembly **23** ([Figure 11e](#)).

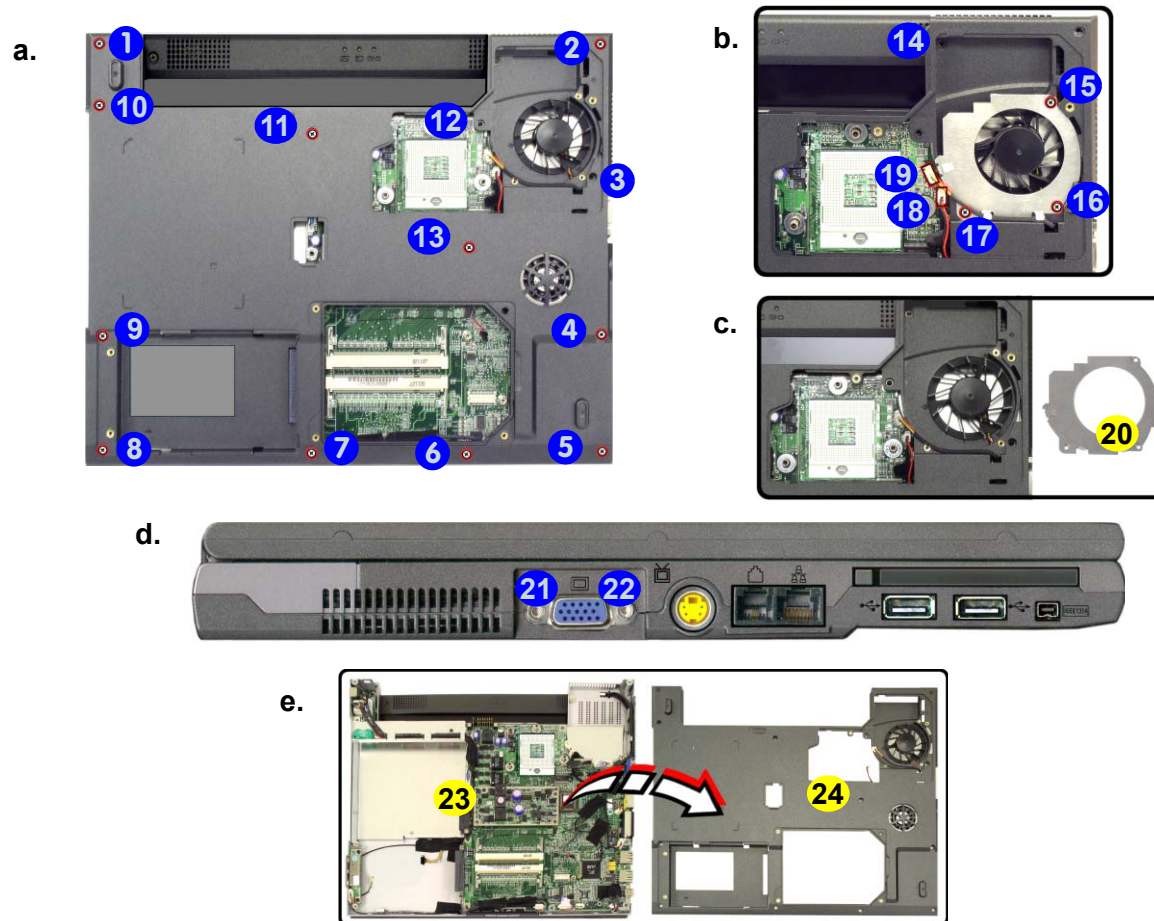

*Figure 11*  
**LCD & Bottom Case Removal**

- a. Remove the screws from the bottom of the computer.
- b. Remove the screws and disconnect the cables.
- c. Lift the fan shield cover.
- d. Remove the screws from the side of the computer.
- e. Lift the bottom case off the LCD and top case assembly.



19. Fan shield cover  
22. LCD & top case  
23. Bottom case

- 19 Screws



### Removing the Audioboard

*Figure 12*  
**Audioboard Removal**

1. Turn **off** the computer, remove the battery ([page 2 - 7](#)), hard disk ([page 2 - 8](#)), CD Device ([page 2 - 12](#)), CPU ([page 2 - 14](#)), and bottom case ([page 2 - 17](#)).
2. Remove screws **1** - **2** and disconnect cables **3** & **4**.
3. Lift the audioboard **5** off the mainboard assembly ([Figure 14b](#)).

- a. Remove screws and disconnect the cables.
- d. Lift the audioboard off the mainboard.

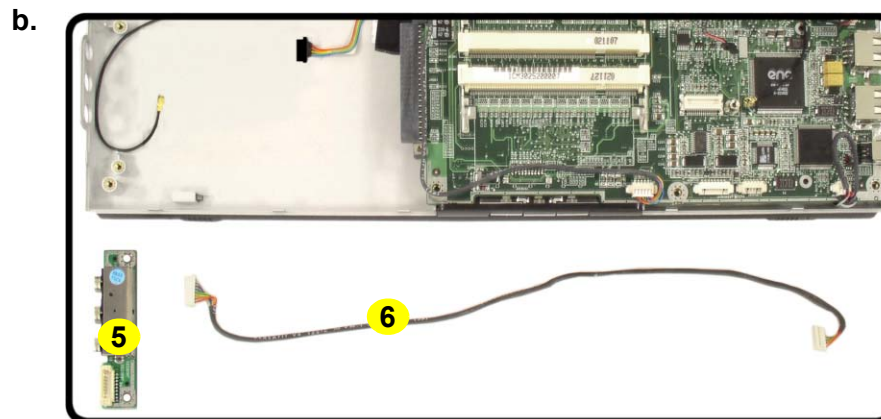
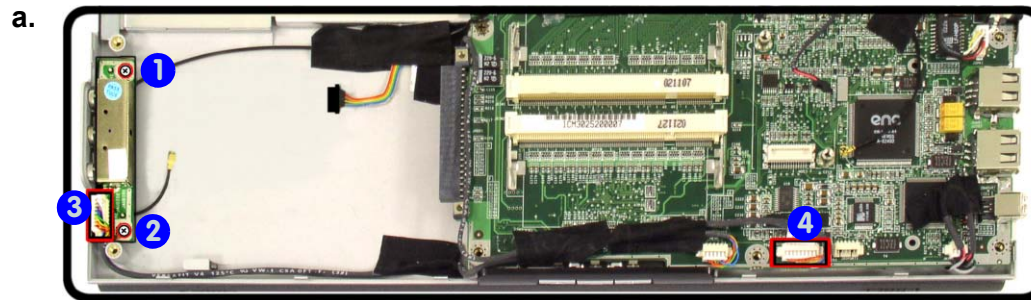

- 5. Audioboard
- 6. Audio Cable

- 2 Screws

## Removing the Multi-function board

1. Turn **off** the computer, remove the battery ([page 2 - 7](#)), hard disk ([page 2 - 8](#)), CD Device ([page 2 - 12](#)), CPU ([page 2 - 14](#)), and bottom case ([page 2 - 17](#)).
2. Remove screws **1** & **2** and disconnect cables **3** - **8** ([Figure 14a](#)).
3. Lift the multi-function board **9** and bracket **10** off the mainboard assembly ([Figure 14b](#)).

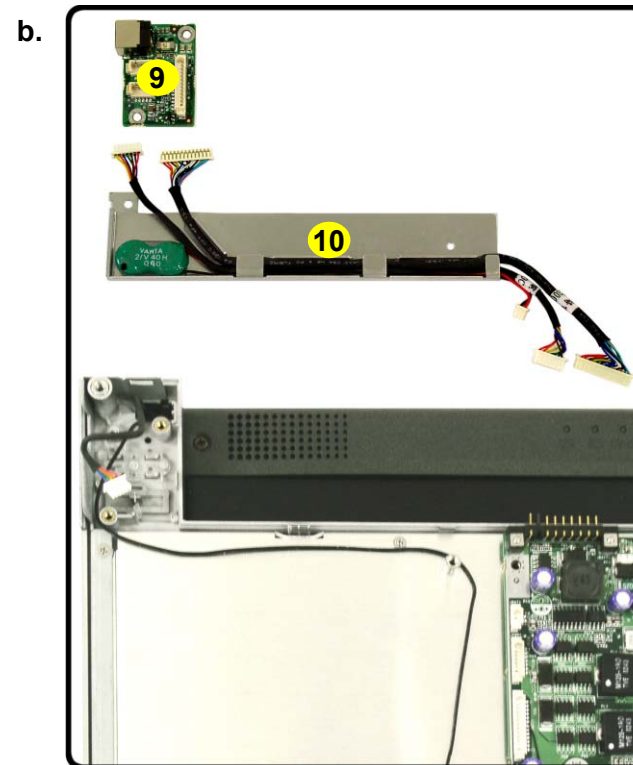
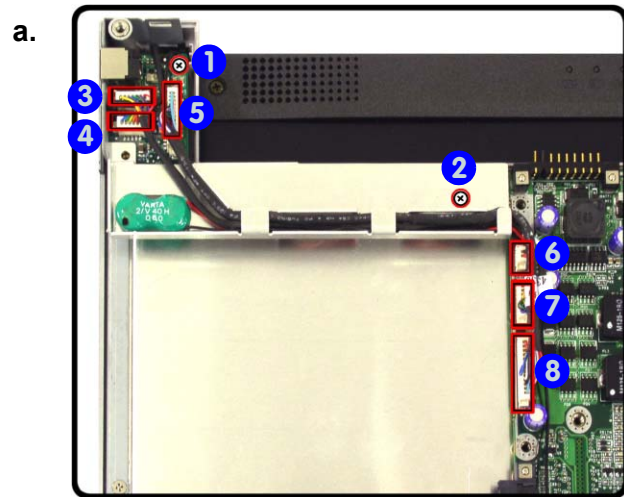

*Figure 13*  
**Multi-function board Removal**

- a. Remove screws and disconnect the cables.
- d. Lift the multi-function-board and bracket off the mainboard assembly.



5. Multi-function board  
10. Bracket

- 2 Screws

### Removing the Mainboard

Figure 14  
Mainboard Removal

- Remove screws.
- Lift the DC/DC board off the mainboard.
- Disconnect the cables and remove the screws.
- Separate the mainboard, and top case. Disconnect the TouchPad cable.

- Turn off the computer, remove the battery (page 2 - 7), hard disk (page 2 - 8), RAM (page 2 - 10), CD Device (page 2 - 12), modem (page 2 - 13), CPU (page 2 - 14), keyboard (page 2 - 16), bottom case (page 2 - 17), and audioboard (page 2 - 18).
- Remove screws 1 - 3 and lift the DC/DC board 4 from the mainboard 5.
- Disconnect cables 6 - 9 and remove screws 10 - 11 (Figure 14c).
- Separate the mainboard 5, and top case 12. Disconnect the TouchPad cable 13 (Figure 14d).

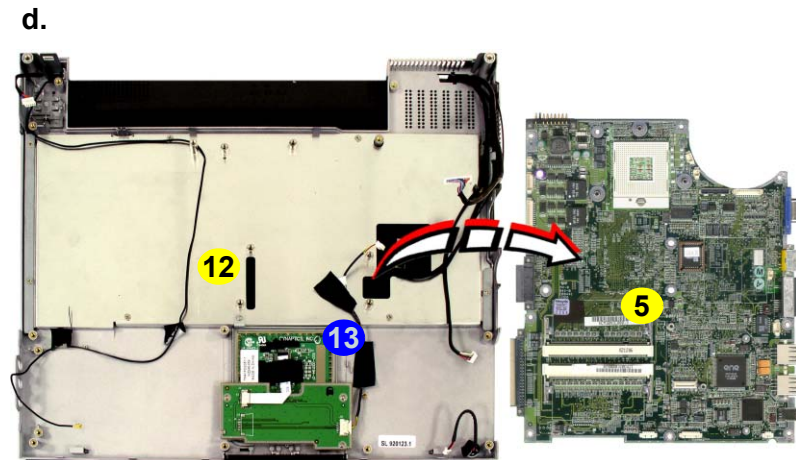
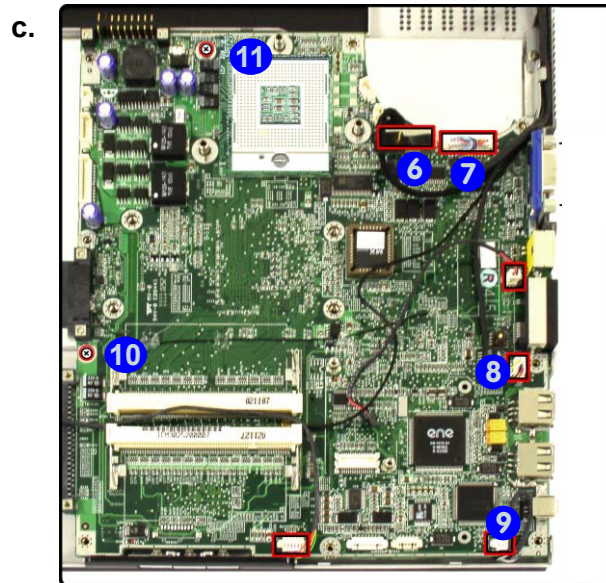
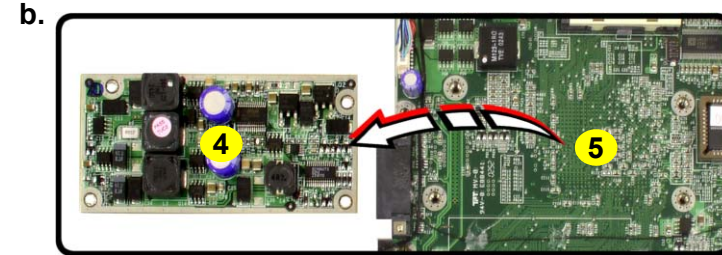
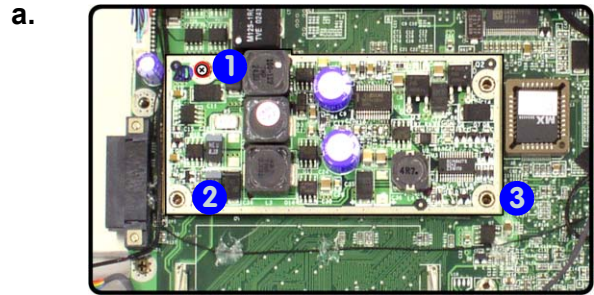

- 4. DC/DC board
- 5. Mainboard
- 16. Bottom case
- 5 Screws

## Removing the TouchPad and Click Board

1. Turn **off** the computer, remove the battery ([page 2 - 7](#)), hard disk ([page 2 - 8](#)), RAM ([page 2 - 10](#)), CD Device ([page 2 - 12](#)), modem ([page 2 - 13](#)), CPU ([page 2 - 14](#)), keyboard ([page 2 - 16](#)), bottom case ([page 2 - 17](#)), audio board ([page 2 - 18](#)), and mainboard ([page 2 - 20](#)).
2. Remove screws **1** - **4** ([Figure 15a](#)) and disconnect cables **5** & **6** from the click board assembly **7**, and lift the assembly off the top case ([Figure 15b](#)).
3. Remove screws **8** - **9** ([Figure 15c](#)).
4. Lift the TouchPad **10** off the top case and separate the TouchPad from its casing **11** ([Figure 15d](#)).

*Figure 15*  
**TouchPad and Click Board Removal**

- a. Remove the screws.
- b. Separate the click board from the top case.
- c. Remove the screws.
- d. Separate the touchpad from the top case.

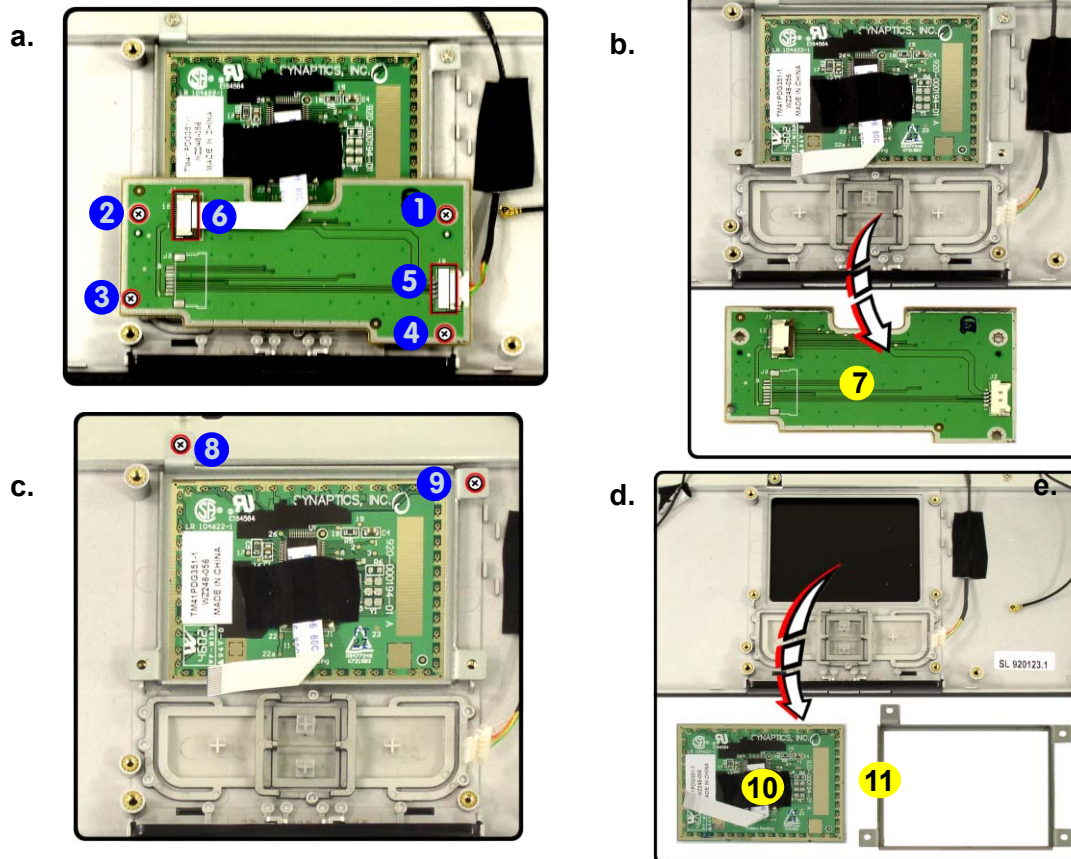



7. Click Board  
10. TouchPad  
11. Casing

- 6 Screws

## Disassembly

### Removing the Inverter

Figure 16

#### Inverter Removal

- Remove the rubber covers and screws.
- Unsnap the frame from the LCD front panel module.
- Remove screw from inverter and disconnect the cables.
- Lift the inverter off the LCD assembly.

- Turn **off** the computer, remove the battery ([page 2 - 7](#)).
- Remove the rubber covers and screw ① - ④ from the LCD ([Figure 16a](#)).
- Run your finger around the middle of the frame to carefully unsnap the LCD front panel module ⑤ from the back.
- Remove screw ⑥ from the inverter over and disconnect the cables ⑦ & ⑧ from the rear of the inverter .
- Lift the inverter ⑨ off the LCD assembly ([Figure 16d](#)).

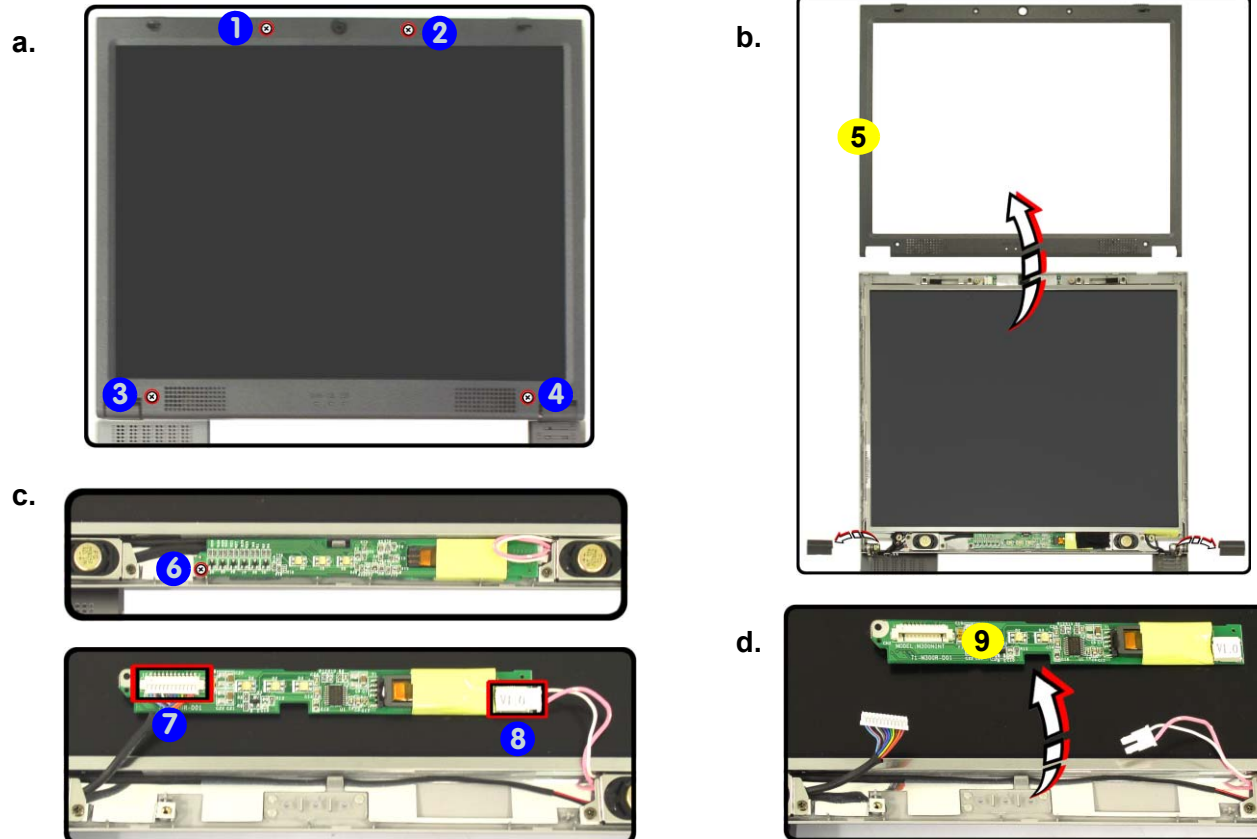

5. LCD Front Panel  
9. Inverter

- 4 Rubber covers
- 5 Screws

## Removing the Speakers

1. Turn **off** the computer, remove the battery ([page 2 - 7](#)), hard disk ([page 2 - 8](#)), CD Device ([page 2 - 12](#)), CPU ([page 2 - 14](#)), bottom case ([page 2 - 17](#)), mainboard ([page 2 - 20](#)), and inverter ([page 2 - 22](#)).
2. Remove the screws **1** - **4** ([Figure 17a](#)) from the speakers.
3. Separate the speakers **5** ([Figure 17b](#)) from the LCD front panel assembly.

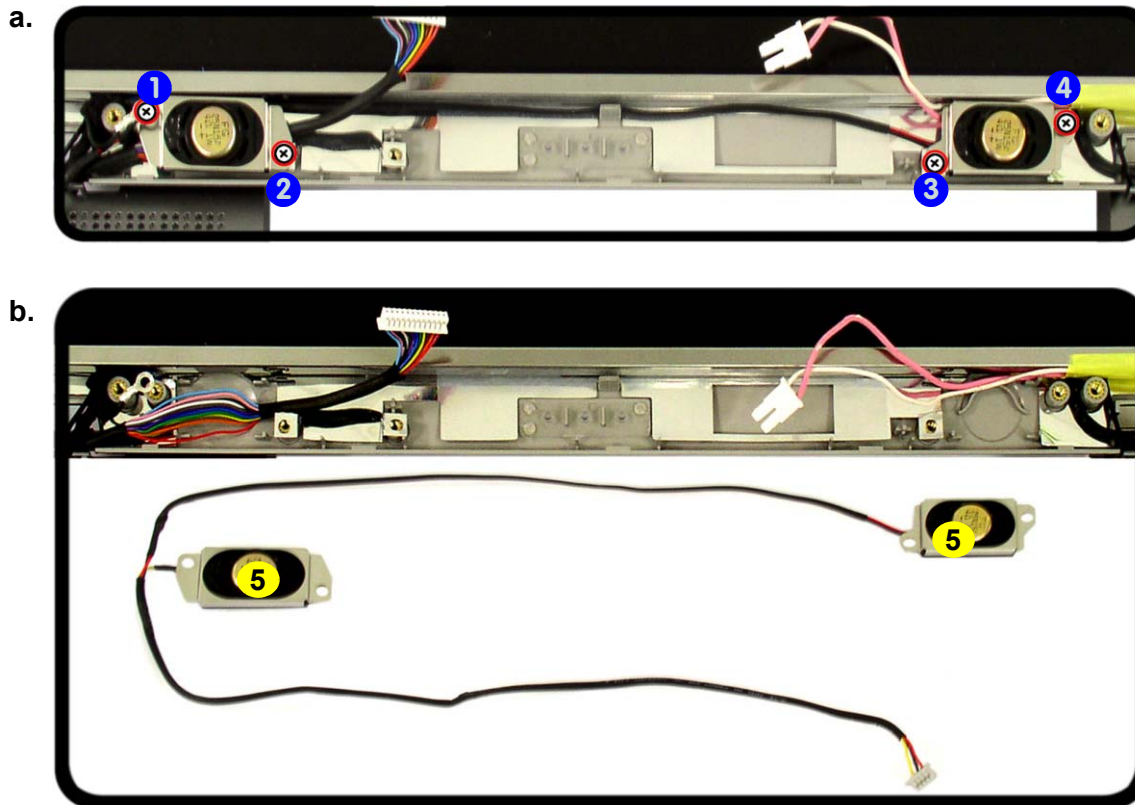

*Figure 17*  
**Speakers Removal**

- a. Remove the screws.
- b. Separate the speakers from the LCD front panel assembly.



5. Speakers
- 4 Screws

## Disassembly

*Figure 18*  
**LCD Panel Removal**

- Remove screws from the side of the LCD panel.
- Lift the LCD panel off the LCD assembly.

## Removing the LCD Panel

- Turn **off** the computer, remove the battery ([page 2 - 7](#)), hard disk ([page 2 - 8](#)), CD Device ([page 2 - 12](#)), CPU ([page 2 - 14](#)), bottom case ([page 2 - 17](#)), mainboard ([page 2 - 20](#)), and inverter ([page 2 - 22](#)).
- Remove screws ① - ④ from the side of the LCD panel ([Figure 18a](#)).
- Gently lift the LCD panel ⑦ off the LCD assembly ([Figure 18b](#)).

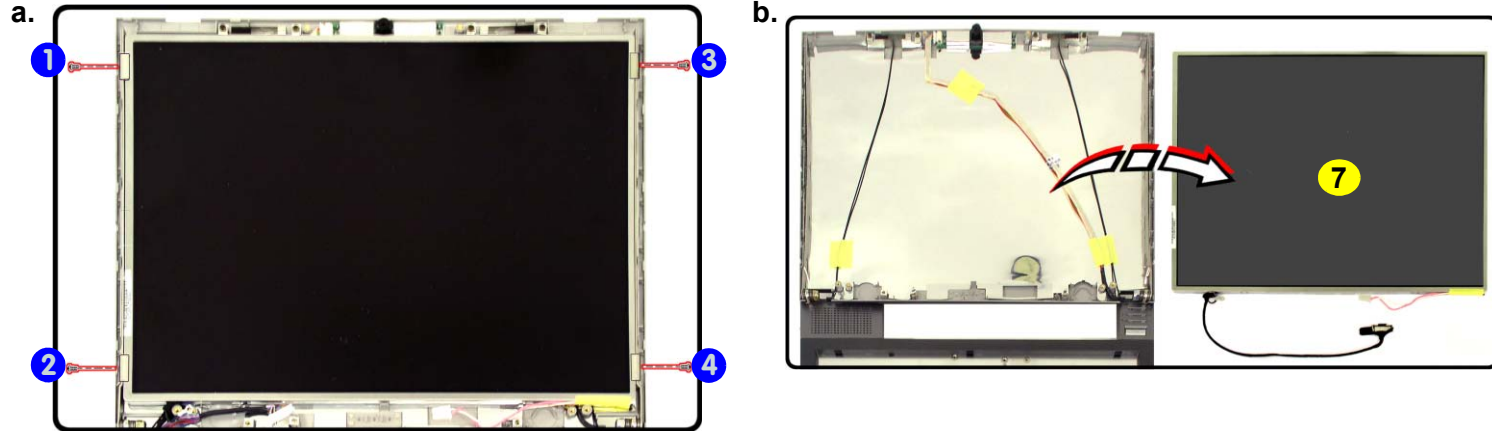

## Removing the PC Camera Module

*Figure 19*  
**PC Camera Removal**

- Disconnect the cable.
- Lift the PC Camera off the LCD assembly.

- Turn **off** the computer, remove the battery ([page 2 - 7](#)), and inverter ([page 2 - 22](#)).
- Disconnect cable ① from the PC camera module ([Figure 19a](#)).
- Lift the PC camera module ② ([Figure 19b](#)) off the LCD assembly.

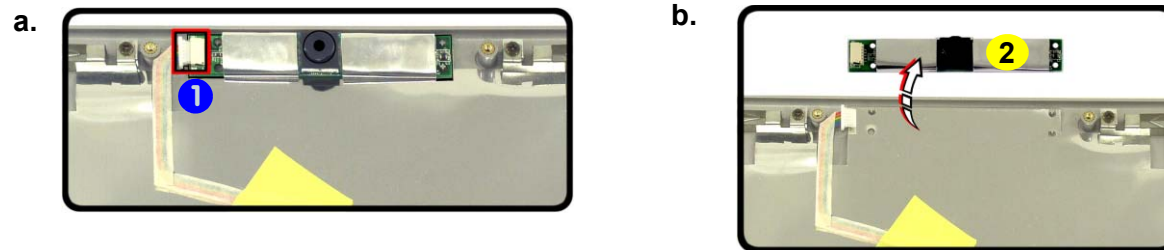

- 7. LCD Panel
- 4 Screws

*Figure 19*  
**PC Camera Removal**

- Disconnect the cable.
- Lift the PC Camera off the LCD assembly.

- Turn **off** the computer, remove the battery ([page 2 - 7](#)), and inverter ([page 2 - 22](#)).
- Disconnect cable ① from the PC camera module ([Figure 19a](#)).
- Lift the PC camera module ② ([Figure 19b](#)) off the LCD assembly.

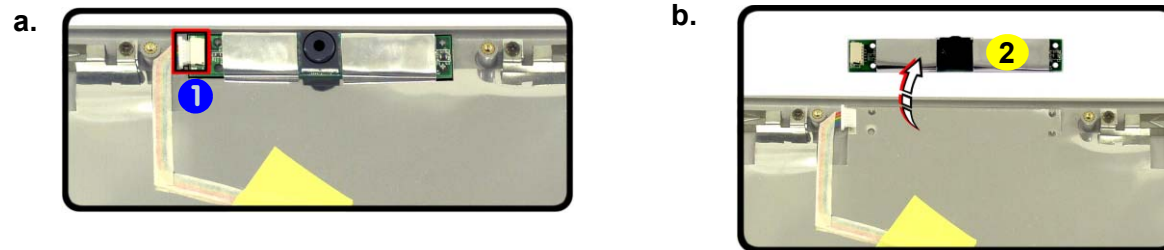

- 2. PC Camera

# Appendix A:Part Lists

This appendix breaks down the *M350C/M360C* series notebook's construction into a series of illustrations. The component part numbers are indicated in the tables opposite the drawings.

**Note:** This section indicates the *manufacturer's* part numbers. Your organization may use a different system, so be sure to cross-check any relevant documentation.

**Note:** Some assemblies may have parts in common (especially screws). However, the part lists DO NOT indicate the total number of duplicated parts used.

**Note:** Be sure to check any update notices. The parts shown in these illustrations are appropriate for the system at the time of publication. Over the product life, some parts may be improved or re-configured, resulting in *new* part numbers.



## Part List Illustration Location

The following table indicates where to find the appropriate part list illustration.

*Table 1 - 1*  
Part List Illustration  
Location

Part	M350C	M360C
Top	<i>page A - 3</i>	<i>page A - 14</i>
Bottom	<i>page A - 4</i>	<i>page A - 15</i>
LCD	<i>page A - 5</i>	<i>page A - 16</i>
CD-ROM Drive - QSI	<i>page A - 6</i>	<i>page A - 17</i>
CD-ROM Drive - SAMSUNG	<i>page A - 7</i>	<i>page A - 18</i>
CD-RW Drive - KME	<i>page A - 8</i>	<i>page A - 19</i>
CD-RW Drive - TEAC	<i>page A - 9</i>	<i>page A - 20</i>
Combo Drive - QSI	<i>page A - 10</i>	<i>page A - 21</i>
Combo Drive - TEAC-SAMSUNG	<i>page A - 11</i>	<i>page A - 22</i>
DVD-ROM Drive - QSI	<i>page A - 12</i>	<i>page A - 23</i>
DVD-ROM Drive - TEAC	<i>page A - 13</i>	<i>page A - 24</i>

# Top (M350C)

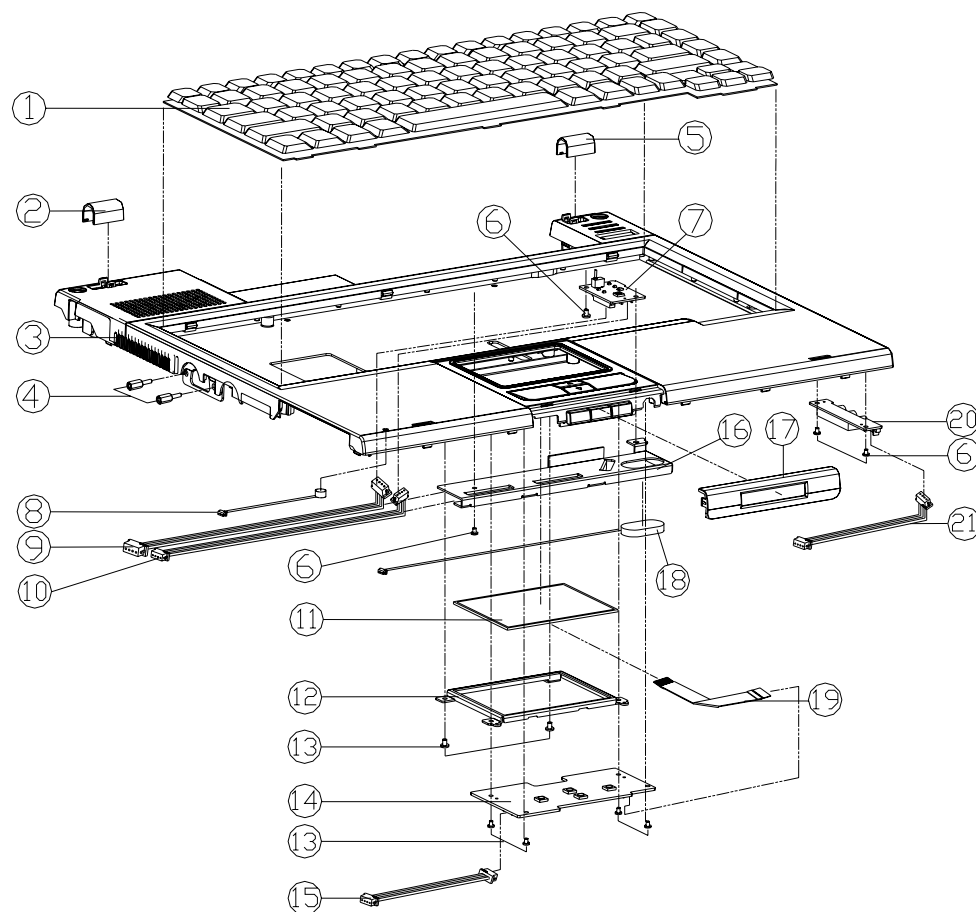

Figure 1  
Top (M350C)

ITEM	PART NAME	PART NO	REMARK
1	KEYBOARD(OPTION)	80-M3008-7G0	
2	HINGE COVER (L)	42-M300Y-040	
3	TOP CASE MODULE	39-M3002-011	
4	HEX STUD (SUM22 NI-PL) 11MM	34-07009-011-A	
5	HINGE COVER(R)	42-M300Y-030	
6	SCREW M2.5*5L K1 BNI ICT NY	35-B9125-5R0	
7	MULTI FUNCTION BOARD	77-M300V-D02	
8	MIC (AMXSEMG050N-12V-10V 22 W/CABLE	23-E0610-55B	
9	WIRE CABLE FOR MULTI-FUNCTION BOARD L=190MM	43-M35C2-010	
10	WIRE CABLE FOR DC POWER L=180MM	43-M300C-010	
11	TOUCH PAD SYNAPTICS TMA1PBG351-1	49-42002-010	
12	TOUCH PAD BRACKET	33-M3002-010	
13	SCREW M2*4L K1 NI ICT NY	35-B1120-4R0	
14	CLICK BOARD	77-M3002-D02	
15	WIRE CABLE FOR CLICK BOARD L=130MM	43-M3002-010	
16	CABLE ALINE PLATE MODULE	33-M3002-500	
17	LENS BASE	42-M3001-D40	
18	BAT. 135mm 2.4V 40mAh 071798P VARTA	23-21302-9B0	
19	CABLE FOR CLICK BOARD	43-32016-001	
20	AUTID ADAPTOR BOARD	77-M3008-D01	
21	WIRE CABLE FOR AUDIO BOARD L=285MM	43-M3008-010	

A.Part Lists

# Bottom (M350C)

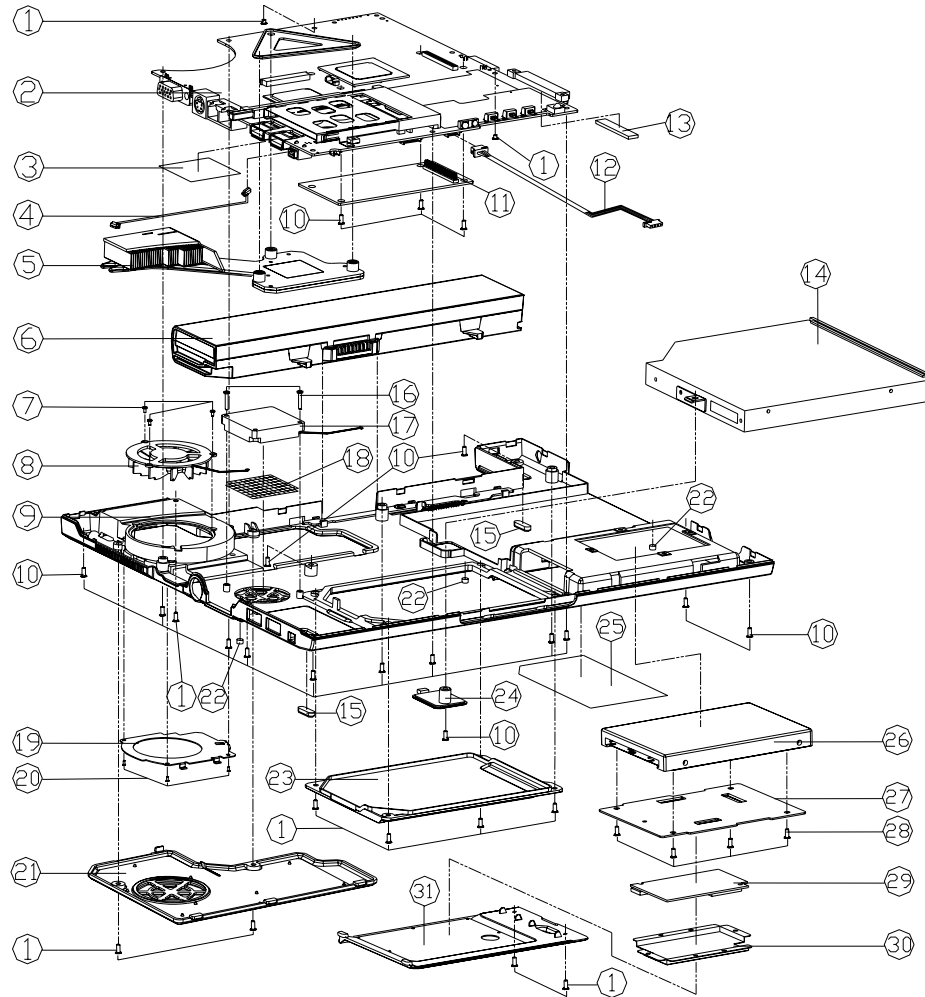
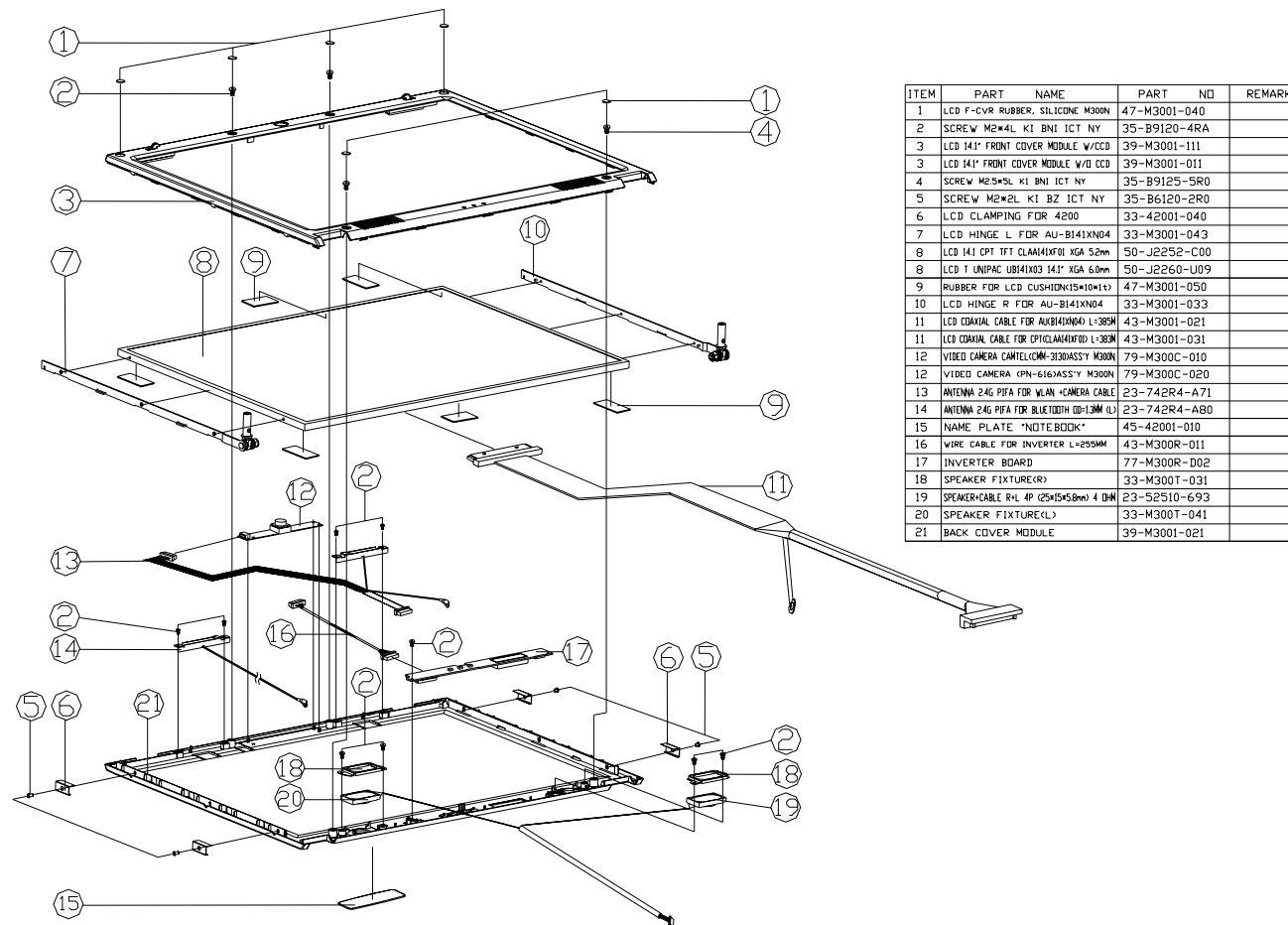

Figure 2  
Bottom (M350C)

ITEM	PART NAME	PART NO	REMARK
1	SCREW M2.5*0.45P*3L K1 BNI ICT NY	35-B9125-3R0	
2	MAIN BOARD	77-M35C0-D0X	FDR M350C
3	MYLAR FDR SYSTEM FAN	40-M300S-060	
4	WTRE CABLE FDR MDC L-70MM M300N	43-M300U-010	
5	CPU HEATSINK	31-M360S-010	
6	BATTERY(OPTION)	87-M308S-495	Reference Assy: Dns C99-M300S-1800
6	BATTERY(OPTION)	87-M300S-445	Reference Assy: Dns C99-M300S-1800
7	SCREW M1.7*3.5L K BZ TAP	35-86717-3R5	
8	FAN 45*45*10T 5V 0.3A CDN	23-A4512-460	
9	BOTTOM CASE MODULE M350C	39-M35C3-010	
10	SCREW M2.5*6L K1 BNI ICT NY	35-B9125-BR0	
11	D/D BOARD	77-M350C-D01	
12	WTRE CABLE FDR WIRELESS LAN L-229MM	43-M300Y-010-1	
13	GASKET(45L*44W*3.5t)	47-00190-454	
14	CD-ROM ASS'Y (OPTION)	79-M300Z-000	Reference Assy: Dns C99-M300S-1800
14	CD-RW ASS'Y (OPTION)	79-M300W-000	Reference Assy: Dns C99-M300S-1800
14	COMBD ASS'Y (OPTION)	79-M300X-000	Reference Assy: Dns C99-M300S-1800
14	DVD-ROM ASS'Y (OPTION)	79-M300V-000	Reference Assy: Dns C99-M300S-1800
15	RUBBER FRONT FOOT	47-D6211-011	
16	SCREW M1.7*6L F NI TAP	35-21717-BR0	
17	FAN 35*35*7.5T 5V 0.14A CDN	23-A3517-050	
18	MESH FDR SYSTEM FAN	33-M300S-040	
19	FAN COVER	33-M300S-020	
20	SCREW M2*4L K1 BNI ICT NY	35-B9120-4RA	
21	CPU COVER MODULE	42-M300S-100	
22	RUBBER FOOT (MIDDLE)	47-M3003-010	
23	RAM COVER MODULE M350C	42-M35C3-100	
24	CD-ROM LOCK COVER	42-M300Z-010	
25	PRODUCT LABEL M350C	45-M35C3-010	
26	W/D HDD ASS'Y	79-M3001-010	
27	HDD FRAME MODULE	33-M3001-100	
28	M3*0.5P*2.5L K1 NI ICT NY	35-B1130-2R5	
29	MINI-PCI WIRELESS LAN CARD INTEL CAPEX100 80211B	88-M3520-420	
30	WLAN SHIELDING FDR M300N	33-M3003-030	
31	HDD COVER MODULE M350C	42-M35C1-100	

# LCD (M350C)



ITEM	PART NAME	PART NO	REMARK
1	LCD F-CVR RUBBER, SILICONE M300N	47-M3001-040	
2	SCREW M2*4L K1 BNI ICT NY	35-B9120-4RA	
3	LCD 14.1" FRONT COVER MODULE W/O CCD	39-M3001-111	
3	LCD 14.1" FRONT COVER MODULE W/O CCD	39-M3001-011	
4	SCREW M2.5*5L K1 BNI ICT NY	35-B9125-5R0	
5	SCREW M2*2L K1 BZ ICT NY	35-B6120-2R0	
6	LCD CLAMPING FOR 4200	33-42001-040	
7	LCD HINGE L FOR AU-B141XN04	33-M3001-043	
8	LCD 14.1 OPT TFT CLAM4(XF01) XGA 52mm	50-J2252-C00	
8	LCD T UNIPAC UB141X03 14.1" XGA 6.0mm	50-J2260-U09	
9	RUBBER FOR LCD CUSHION(K15*10*1.5)	47-M3001-050	
10	LCD HINGE R FOR AU-B141XN04	33-M3001-033	
11	LCD COAXIAL CABLE FOR AK(B141XN04) L=383M	43-M3001-021	
11	LCD COAXIAL CABLE FOR OPTIC(LAM410FD) L=383M	43-M3001-031	
12	VIDEO CAMERA CAMEL(CM-310)ASSY M300N	79-M300C-010	
12	VIDEO CAMERA (PN-616)ASSY M300N	79-M300C-020	
13	ANTENNA 2.4G PIFA FOR WLAN *CAMERA CABLE	23-742R4-A71	
14	ANTENNA 2.4G PIFA FOR BLUETOOTH (D=1.3MM) (L)	23-742R4-A80	
15	NAME PLATE "NOTEBOOK"	45-42001-010	
16	WIRE CABLE FOR INVERTER L=255MM	43-M300R-011	
17	INVERTER BOARD	77-M300R-D02	
18	SPEAKER FIXTURE(R)	33-M300T-031	
19	SPEAKER CABLE R/L 4P (25*15*5.0mm) 4.0HM	23-52510-693	
20	SPEAKER FIXTURE(L)	33-M300T-041	
21	BACK COVER MODULE	39-M3001-021	

Figure 3  
LCD (M350C)

A.Part Lists

## CD-ROM Drive - QSI (M350C)

Figure 4  
CD-ROM Drive -  
QSI (M350C)

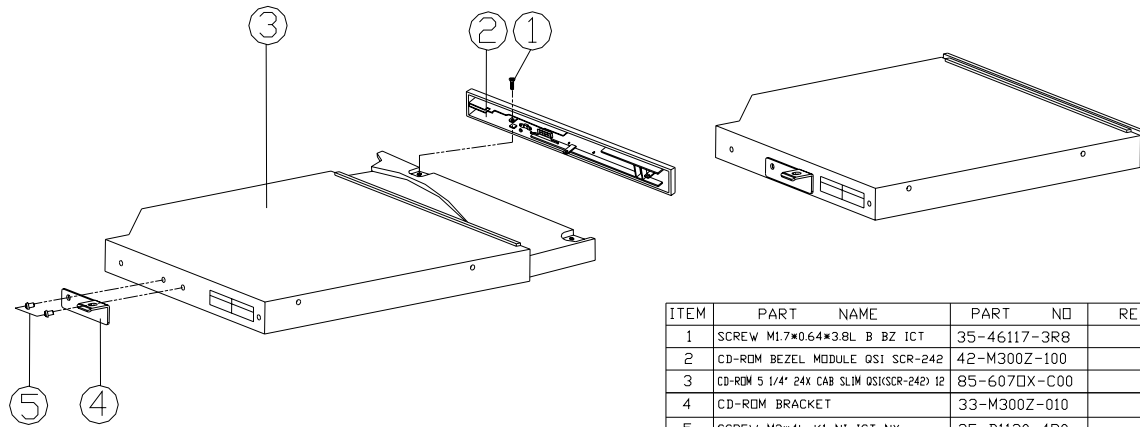

ITEM	PART NAME	PART NO	REMARK
1	SCREW M1.7*0.64*3.8L B BZ ICT	35-46117-3R8	
2	CD-ROM BEZEL MODULE QSI SCR-242	42-M300Z-100	
3	CD-ROM 5 1/4" 24X CAR SLIM QSI(SCR-242) 12	85-607□X-C00	
4	CD-ROM BRACKET	33-M300Z-010	
5	SCREW M2*4L K1 NI ICT NY	35-B1120-4R0	

# CD-ROM Drive - SAMSUNG (M350C)

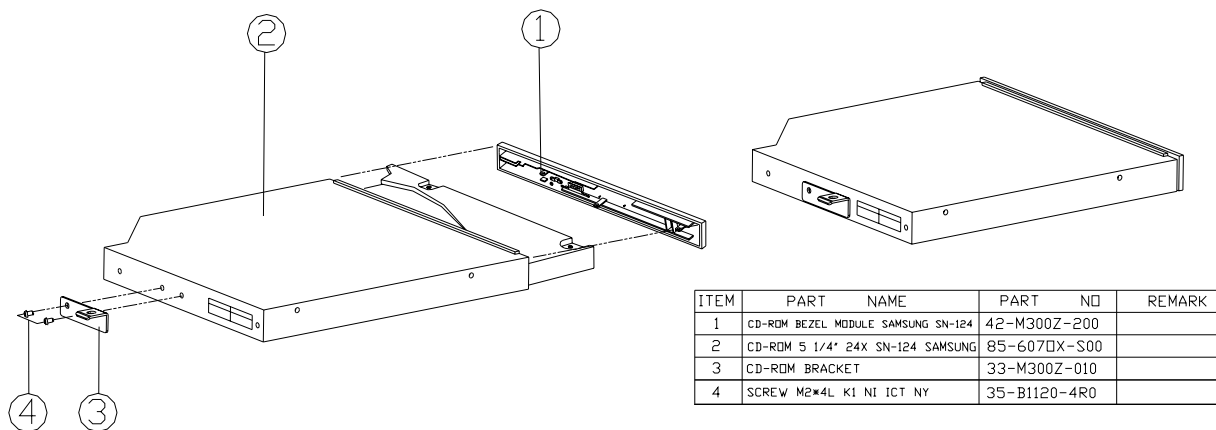

ITEM	PART NAME	PART NO	REMARK
1	CD-ROM BEZEL MODULE SAMSUNG SN-124	42-M300Z-200	
2	CD-ROM 5 1/4" 24X SN-124 SAMSUNG	85-607DX-S00	
3	CD-ROM BRACKET	33-M300Z-010	
4	SCREW M2*4L K1 NI ICT NY	35-B1120-4R0	

Figure 5  
CD-ROM Drive -  
SAMSUNG  
(M350C)

A.Part Lists

## CD-RW Drive - KME (M350C)

Figure 6  
CD-RW Drive -  
KME (M350C)

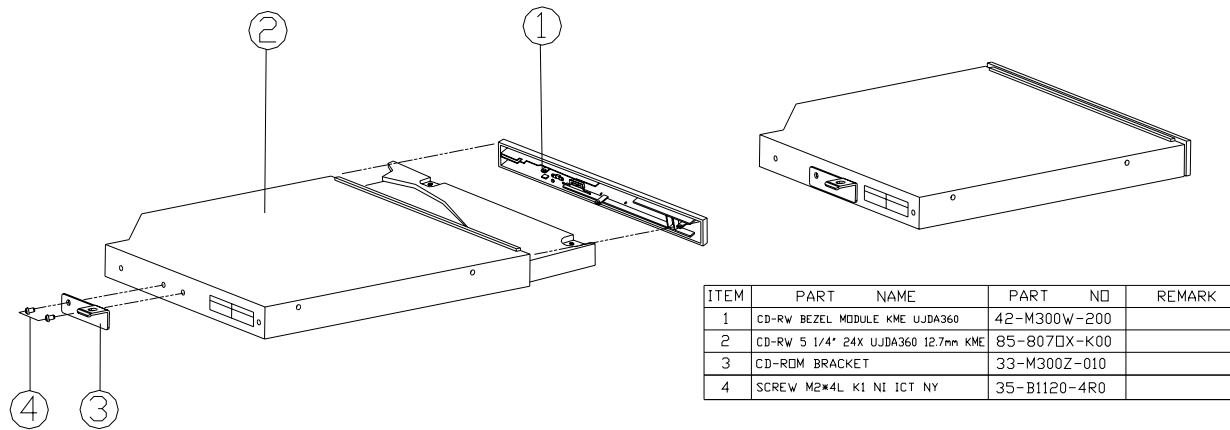

# CD-RW Drive - TEAC (M350C)

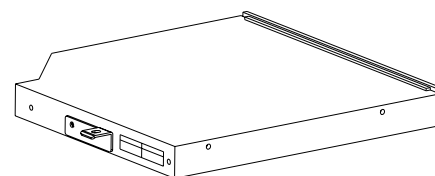
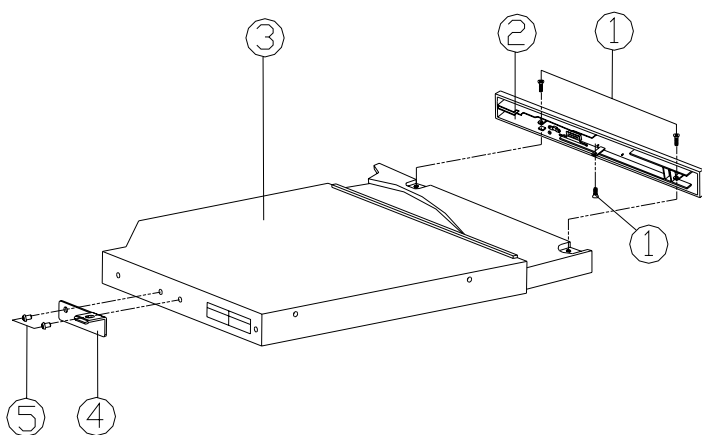

Figure 7  
CD-RW Drive -  
TEAC (M350C)

ITEM	PART NAME	PART NO	REMARK
1	SCREW M2*5L K1 BK/D TAP/	35-B4920-5R0	
2	CD-RW BEZEL MODULE TEAC CD-W224E-AB2	42-M300W-100	
3	CD-RW 5 1/4" 24X CD-W224E-AB2 12.7mm TEAC	85-8070X-700	
4	CD-ROM BRACKET	33-M300Z-010	
5	SCREW M2*4L K1 NI ICT NY	35-B1120-4R0	



## Combo Drive - QSI (M350C)

Figure 8  
Combo Drive - QSI  
(M350C)

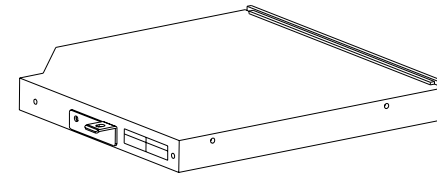
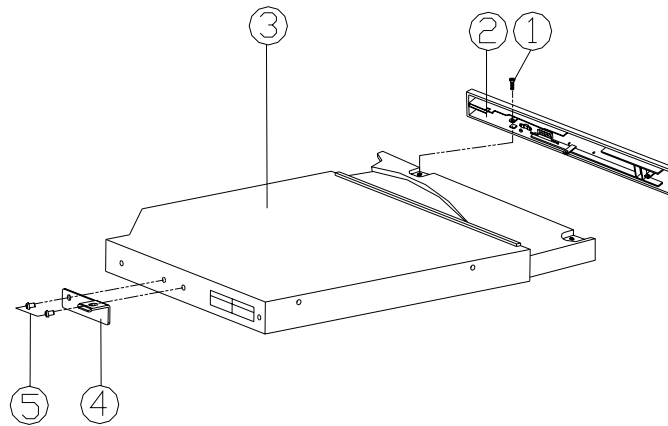

ITEM	PART NAME	PART NO	REMARK
1	SCREW M1.7*0.64*3.8L B BZ ICT	35-46117-3R8	
2	COMBO DRIVE BEZEL MODULE QSI SBW-241	42-M300X-100	
3	CD-RW/DVD 5 1/4" 24X 12.7mm SBW-241 QSI	85-907DX-C00	
4	CD-R/DVD BRACKET	33-M300Z-010	
5	SCREW M2*4L K1 NI ICT NY	35-B1120-4R0	

# Combo Drive - TEAC-SAMSUNG (M350C)

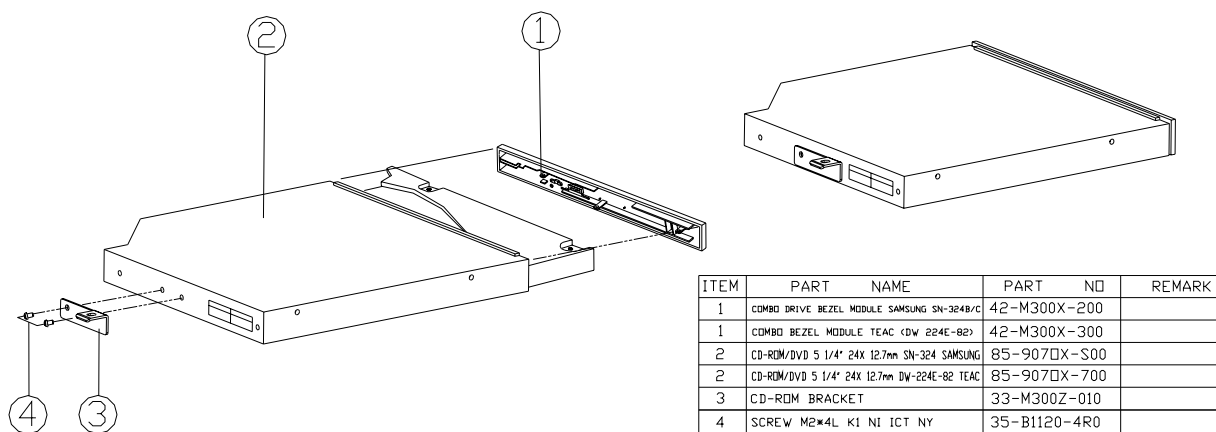
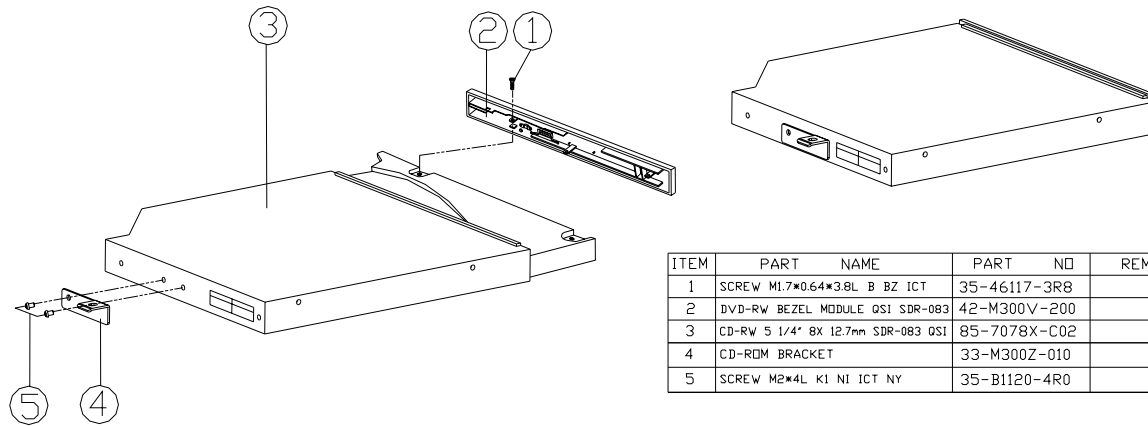

Figure 9  
 Combo Drive -  
 TEAC-SAMSUNG  
 (M350C)

A.Part Lists

## DVD-ROM Drive - QSI (M350C)

Figure 10  
DVD-ROM Drive -  
QSI (M350C)



ITEM	PART NAME	PART NO	REMARK
1	SCREW M1.7*0.64*3.8L B BZ ICT	35-46117-3R8	
2	DVD-RW BEZEL MODULE QSI SDR-083	42-M300V-200	
3	CD-RW S 1/4" 8X 12.7mm SDR-083 QSI	85-7078X-C02	
4	CD-ROM BRACKET	33-M300Z-010	
5	SCREW M2*4L K1 NI ICT NY	35-B1120-4R0	

# DVD-ROM Drive - TEAC (M350C)

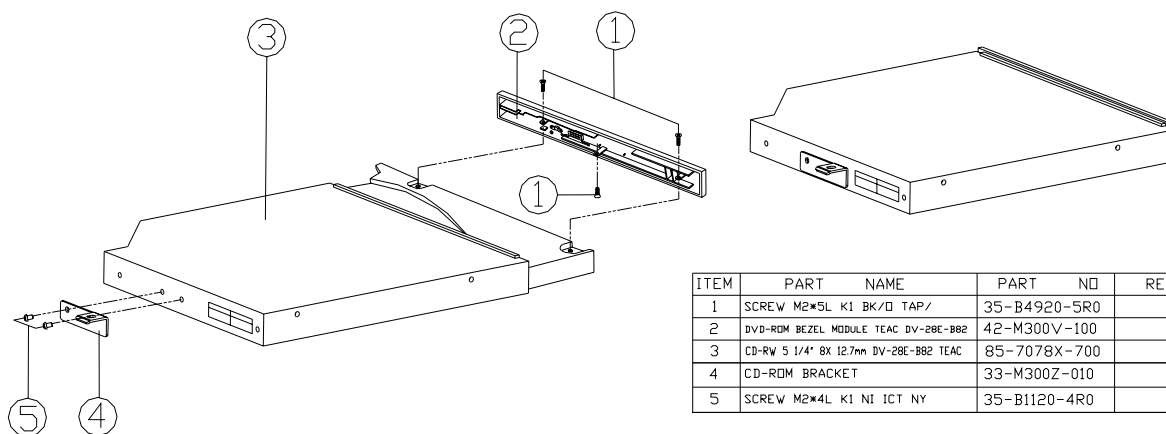

ITEM	PART NAME	PART NO	REMARK
1	SCREW M2*SL K1 BK/D TAP/	35-B4920-5R0	
2	DVD-ROM BEZEL MODULE TEAC DV-28E-B82	42-M300V-100	
3	CD-RW 5 1/4' 8X 12.7mm DV-28E-B82 TEAC	85-7078X-700	
4	CD-ROM BRACKET	33-M300Z-010	
5	SCREW M2*4L K1 NI ICT NY	35-B1120-4R0	

Figure 11  
DVD-ROM Drive -  
TEAC (M350C)

A.Part Lists

# Top (M360C)

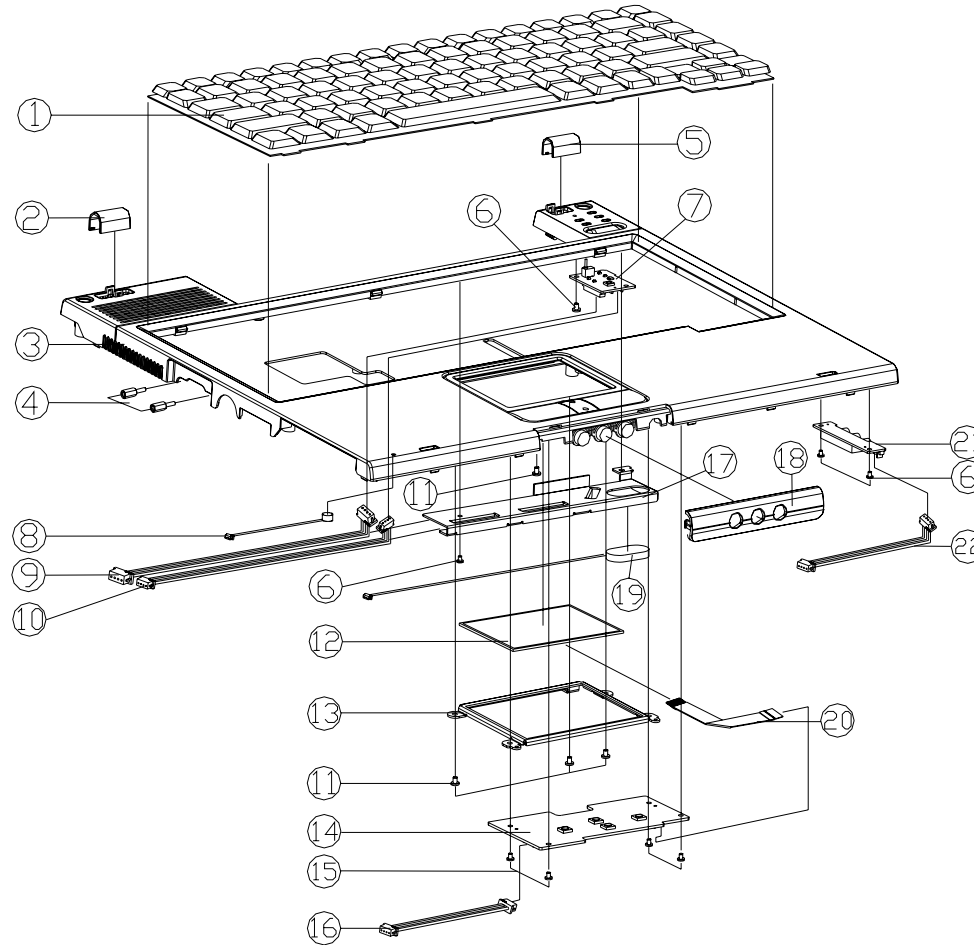
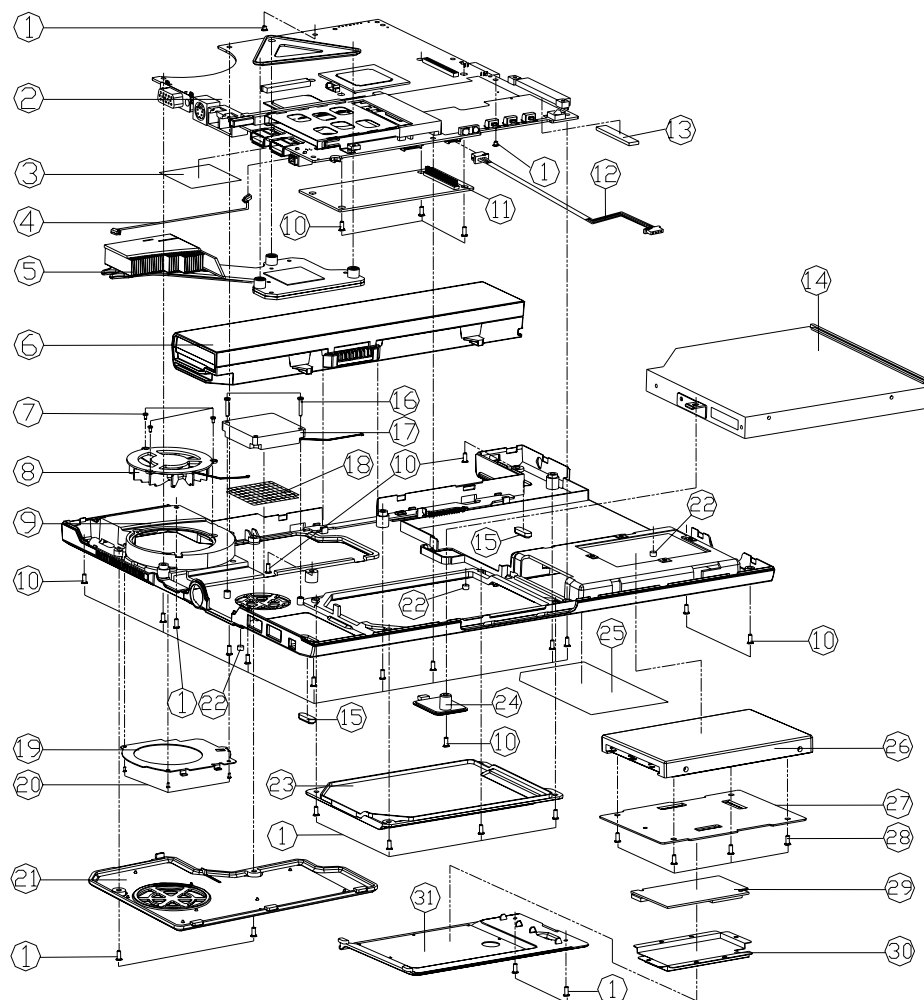

Figure 12  
Top (M360C)

ITEM	PART NAME	PART NO	REMARK
1	KEYBOARD(OPTION)	80-M3008-7G0	
2	HINGE COVER (L)	42-M360Y-040	
3	TOP CASE MODULE M360C	39-M3602-011	
4	HEX STUD (SUM22 NI-PL) 11MM	34-07009-011-A	
5	HINGE COVER(R)	42-M360Y-030	
6	SCREW M2.5*5L K1 BNI ICT NY	35-B9125-5R0	
7	MULTI FUNCTION BOARD	77-M300V-D02	
8	MIC 6MMX56MMX12V-0V 22 W/CABLE	23-E0610-55B	
9	WIRE CABLE FOR MULTI-FUNCTION BOARD L=180MM	43-M35C2-010	
10	WIRE CABLE FOR DC POWER L=180MM	43-M300C-010	
11	SCREW M2*3L K1 NI ICT	35-B1120-3R0	
12	TOUCH PAD SYNAPTICS TM41PG251-I	49-42002-010	
13	TOUCH PAD BRACKET	33-M3602-010	
14	CLICK BOARD	77-M3002-D02	
15	SCREW M2*4L K1 NI ICT NY	35-B1120-4R0	
16	WIRE CABLE FOR CLICK BOARD L=130MM	43-M3002-010	
17	CABLE ALINE PLATE MODULE	33-M3002-500	
18	LENS BASE	42-M3601-040	
19	BAT. 13.5mm 2.4V 40mAh 071798P VARTA	33-21302-9B0	
20	CABLE FOR CLICK BOARD	43-32016-001	
21	AUDIO ADAPTOR BOARD	77-M3008-D01	
22	WIRE CABLE FOR AUDIO BOARD L=285MM	43-M3008-010	

# Bottom (M360C)



ITEM	PART NAME	PART NO	REMARK
1	SCREW M2.5*0.45P*3L K1 BN ICT NY	35-B9125-3R0	
2	MAIN BOARD	77-M35CO-DOX	
3	MYLAR FDR SYSTEM FAN	40-M300S-060	
4	WIRE CABLE FOR HDD L*70MM M300N	43-M300U-010	
5	CPU HEATSINK FDR M360B	31-M360S-010	
6	BATTERY(OPTION)	87-M30BS-495	Reference Assy. Bkg (99-M300C-080)
6	BATTERY(OPTION)	87-M300S-445	Reference Assy. Bkg (99-M300S-080)
7	SCREW M1.7*3.5L K BZ TAP	35-86717-3R5	
8	FAN 45*45*10T 5V 0.3A CDL	23-A4512-460	
9	BOTTOM CASE MODULE M360C	39-M36C3-010	
10	SCREW M2.5*8L K1 BNI ICT NY	35-B9125-8R0	
11	D/D BOARD	77-M300C-D02	
12	WIRE CABLE FOR WIRELESS LAN L=225MM	43-M300Y-010-1	
13	GASKET(45L*4W*3.5t)	47-00190-454	
14	CD-ROM ASS'Y (OPTION)	79-M360Z-000	Reference Assy. Bkg (99-M360C-040)
14	CD-RW ASS'Y (OPTION)	79-M360V-000	Reference Assy. Bkg (99-M360C-050)
14	CDRW ASS'Y (OPTION)	79-M360X-000	Reference Assy. Bkg (99-M360C-060)
14	DVD-ROM ASS'Y (OPTION)	79-M360Y-000	Reference Assy. Bkg (99-M360C-070)
15	RUBBER FRONT FOOT	47-D6211-011	
16	SCREW M1.7*8L F NI TAP	35-21717-8R0	
17	FAN 35*35*7.5T 5V 0.14A CDL	23-A3517-050	
18	MESH FOR SYSTEM FAN	33-M300S-040	
19	FAN COVER	33-M300S-020	
20	SCREW M2*4L K1 BNI ICT NY	35-B9120-4RA	
21	CPU COVER MODULE	42-M360S-100	
22	RUBBER FOOT (MIDDLE)	47-M3003-010	
23	RAM COVER MODULE M360C	42-M36C3-100	
24	CD-ROM LOCK COVER	42-M360Z-010	
25	PRODUCT LABEL FDR M360C	45-M36C3-010	
26	W/O HDD ASS'Y	79-M3001-010	
27	HDD FRAME MODULE	33-M3001-100	
28	M3*0.5P*2.5L K1 NI ICT NY	35-B1130-2R5	
29	MINI-PCI WIRELESS LAN CARD INTEL CALEXRD 802.11b	88-M3520-420	
30	WLAN SHIELDING FDR M300N	33-M3003-030	
31	HDD COVER MODULE M360C	42-M36C1-100	

Figure 13  
Bottom (M360C)

A.Part Lists

# LCD (M360C)

Figure 14  
LCD (M360C)

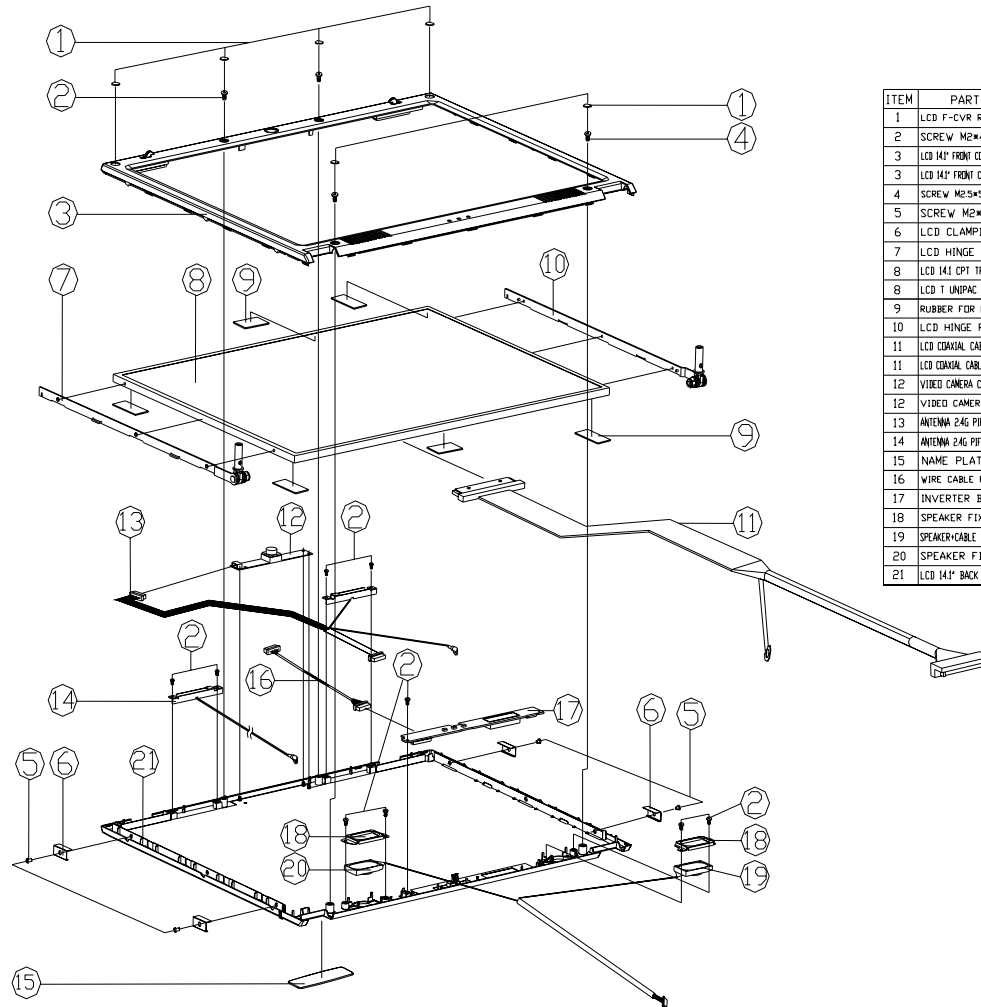

ITEM	PART NAME	PART NO	REMARK
1	LCD F-CVR RUBBER, SILICONE M360N	47-M36C1-040	
2	SCREW M2*4L K1 BNI ICT NY	35-B9120-4RA	
3	LED 141" FRONT COVER MODULE W/CCD FOR M360B	39-M3601-111	
3	LED 141" FRONT COVER MODULE W/0 CCD M360B	39-M3601-011	
4	SCREW M2*5SL K1 BNI ICT NY	35-B9125-5R0	
5	SCREW M2*4L K1 BNI ICT NY	35-B9120-4RA	
6	LCD CLAMPING FDR 4200	33-42001-040	
7	LCD HINGE L FDR AU-B141XN04	33-M3001-043	
8	LED 141 OPT TFT CLAMPING FOR XGA 52mm	50-J2252-C00	
8	LED 1 UNIPAC UB141X03 141" XGA 6.0mm	50-J2260-U09	
9	RUBBER FOR LCD CUSHION(15*10*1.5)	47-M3001-050	
10	LCD HINGE R FDR AU-B141XN04	33-M3001-033	
11	LED COAXIAL CABLE FOR AUR814XN04 L=385MM	43-M3001-021	
11	LED COAXIAL CABLE FOR OPTICLAN41XFD0 L=385MM	43-M3001-031	
12	VIDEO CAMERA CAMEL(CM-3130)ASSY M360N	79-M300C-010	
12	VIDEO CAMERA (PN-616)ASSY M360N	79-M300C-020	
13	ANTENNA 2.4G PIFA FOR WLAN +CAMERA CABLE	23-742R4-A71	
14	ANTENNA 2.4G PIFA FOR BLUETOOTH DB-13MM (L)	23-742R4-A80	
15	NAME PLATE "NOTE BOOK"	45-42001-010	
16	WIRE CABLE FOR INVERTER L=295MM	43-M300R-011	
17	INVERTER BOARD	77-M300R-D02	
18	SPEAKER FIXTURE(R)	33-M3001-031	
19	SPEAKER CABLE RHL 4P (25x15x58mm) 4 DM	23-52510-693	
20	SPEAKER FIXTURE(L)	33-M3001-041	
21	LCD 141" BACK COVER MODULE FOR M360B	39-M3601-021	

# CD-ROM Drive - QSI (M360C)

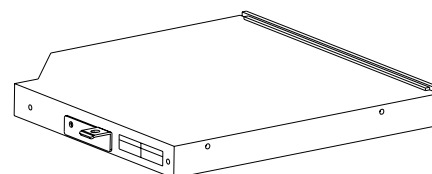
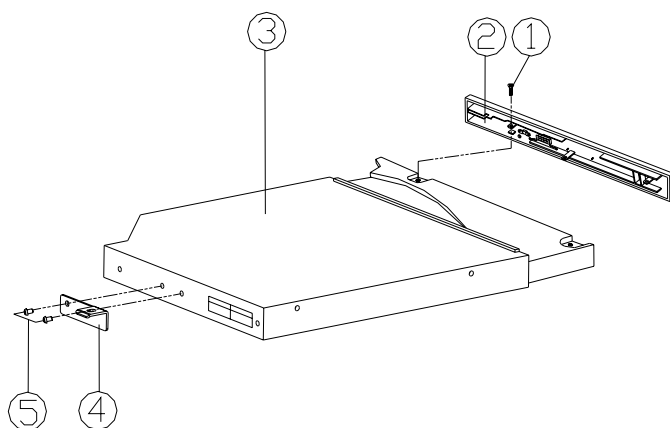

ITEM	PART NAME	PART NO	REMARK
1	SCREW M1.7*0.64*3.8L B BZ ICT	35-46117-3R8	
2	CD-ROM BEZEL MODULE QSI SCR-242	42-M360Z-100	
3	CD-ROM 5 1/4" 24X CAB SLIM QSI(SCR-242) 12.7MM	85-607DX-C00	
4	CD-ROM BRACKET	33-M300Z-010	
5	SCREW M2*4L K1 NI ICT NY	35-B1120-4R0	

Figure 15  
CD-ROM Drive -  
QSI (M360C)

A.Part Lists



## CD-ROM Drive - SAMSUNG (M360C)

Figure 16  
CD-ROM Drive -  
SAMSUNG  
(M360C)

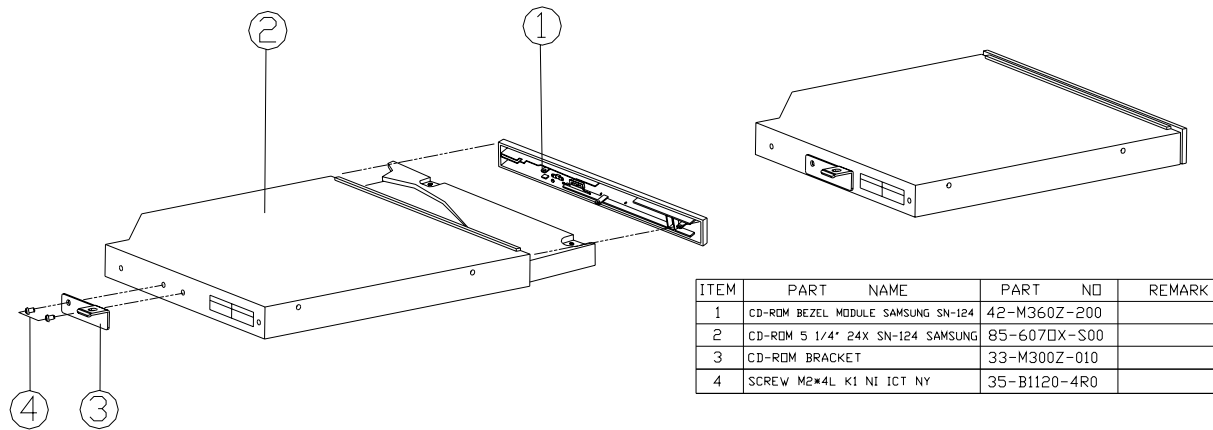

# CD-RW Drive - KME (M360C)

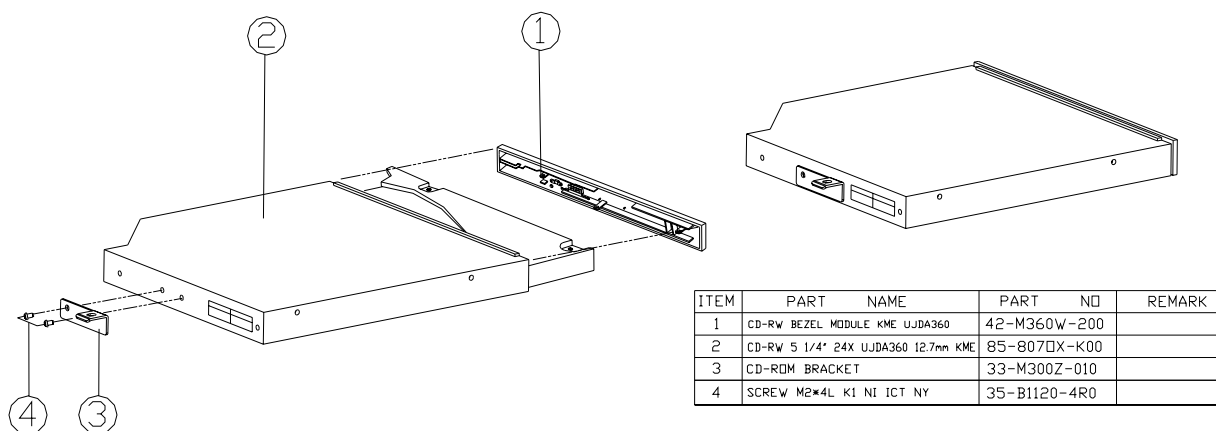
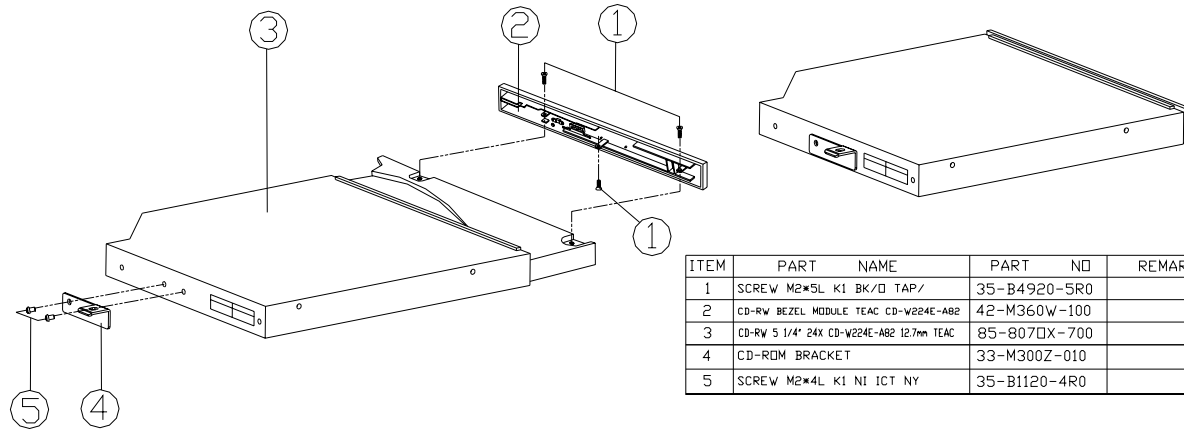

Figure 17  
CD-RW Drive -  
KME (M360C)

A.Part Lists

## CD-RW Drive - TEAC (M360C)

Figure 18  
CD-RW Drive -  
TEAC (M360C)



ITEM	PART NAME	PART NO	REMARK
1	SCREW M2*5L K1 BK/O TAP/	35-B4920-5R0	
2	CD-RW BEZEL MODULE TEAC CD-W224E-AB2	42-M360W-100	
3	CD-RW 5 1/4" 24x CD-W224E-AB2 12.7mm TEAC	85-807DX-700	
4	CD-ROM BRACKET	33-M300Z-010	
5	SCREW M2*4L K1 NI ICT NY	35-B1120-4R0	

# Combo Drive - QSI (M360C)

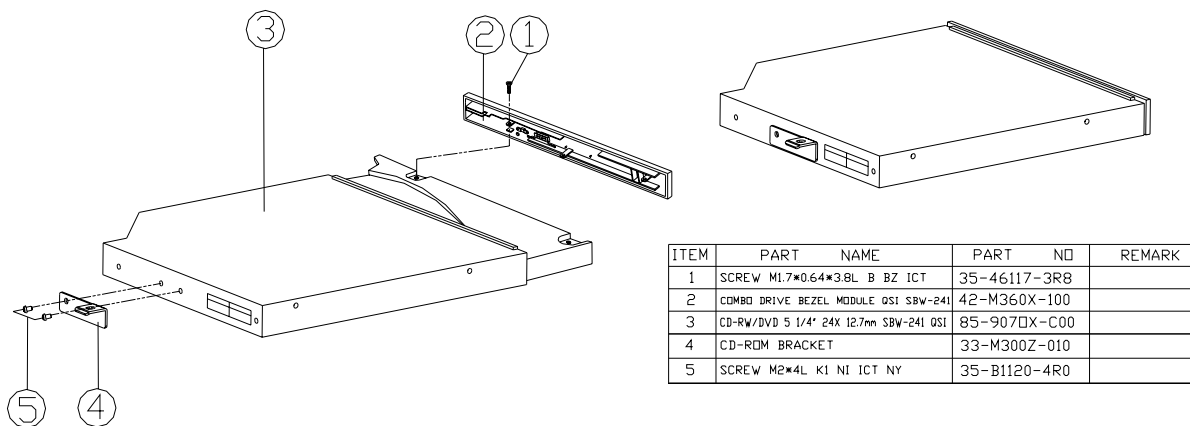
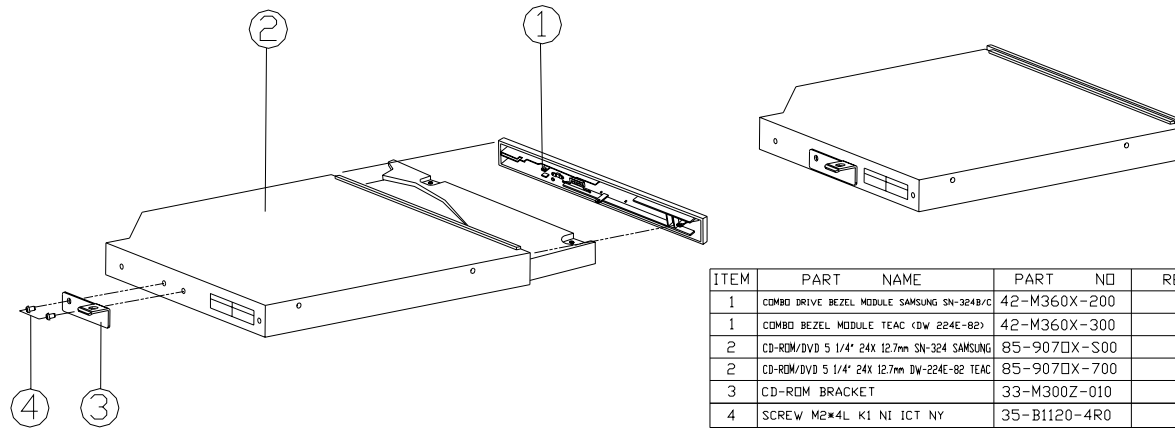

Figure 19  
Combo Drive - QSI  
(M360C)

## Combo Drive - TEAC-SAMSUNG (M360C)

Figure 20  
 Combo Drive -  
 TEAC-SAMSUNG  
 (M360C)



ITEM	PART NAME	PART NO	REMARK
1	COMBO DRIVE BEZEL MODULE SAMSUNG SN-324B/C	42-M360X-200	
1	COMBO BEZEL MODULE TEAC (DW 224E-82)	42-M360X-300	
2	CD-ROM/DVD 5 1/4" 24X 12.7mm SN-324 SAMSUNG	85-907□X-S00	
2	CD-ROM/DVD 5 1/4" 24X 12.7mm DW-224E-82 TEAC	85-907□X-700	
3	CD-ROM BRACKET	33-M300Z-010	
4	SCREW M2*4L K1 NI ICT NY	35-B1120-4R0	

# DVD-ROM Drive - QSI (M360C)

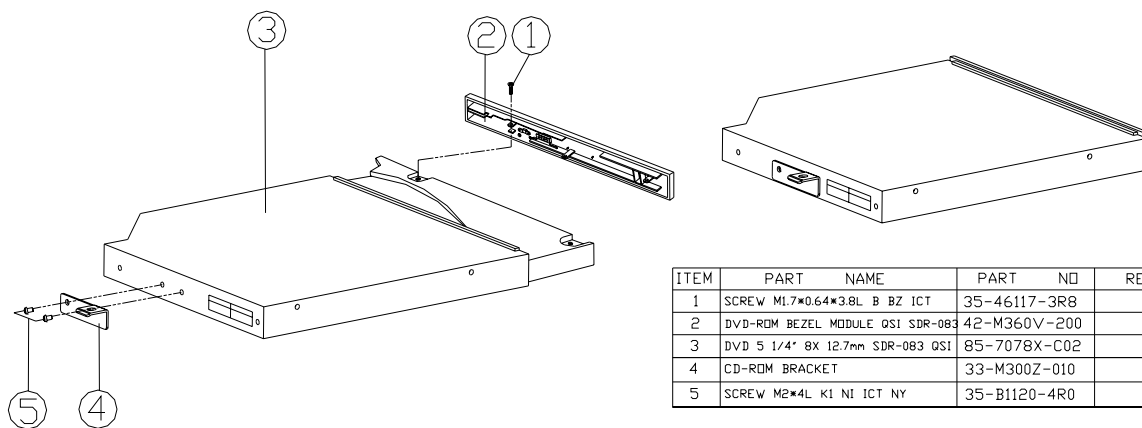

ITEM	PART NAME	PART NO	REMARK
1	SCREW M1.7*0.64*3.8L B BZ ICT	35-46117-3R8	
2	DVD-ROM BEZEL MODULE QSI SDR-083	42-M360V-200	
3	DVD 5 1/4" 8X 12.7mm SDR-083 QSI	85-7078X-C02	
4	CD-ROM BRACKET	33-M300Z-010	
5	SCREW M2*4L K1 NI ICT NY	35-B1120-4R0	

Figure 21  
DVD-ROM Drive -  
QSI (M360C)

A.Part Lists

## DVD-ROM Drive - TEAC (M360C)

Figure 22  
DVD-ROM Drive -  
TEAC (M360C)

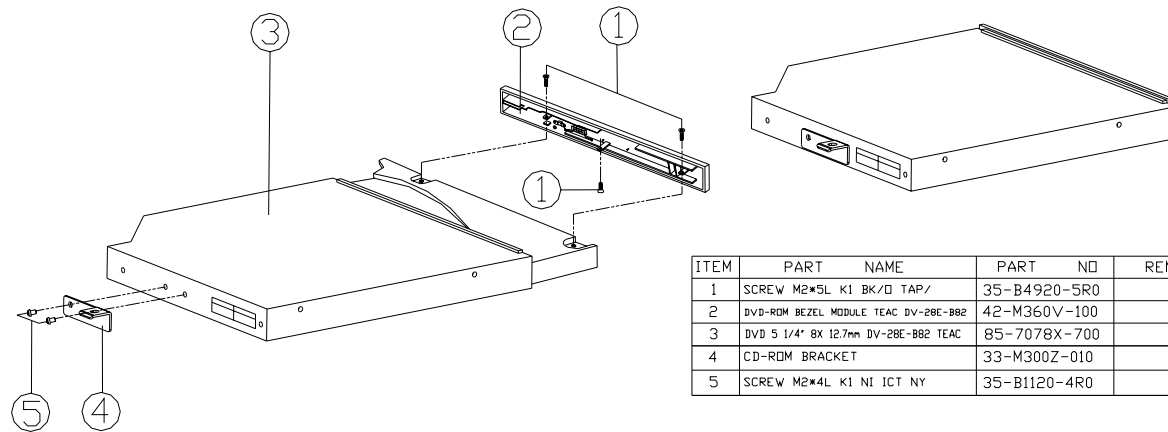

ITEM	PART NAME	PART NO	REMARK
1	SCREW M2*SL K1 BK/D TAP/	35-B4920-5R0	
2	DVD-ROM BEZEL MODULE TEAC DV-28E-BB2	42-M360V-100	
3	DVD 5 1/4" 8X 12.7mm DV-28E-BB2 TEAC	85-7078X-700	
4	CD-ROM BRACKET	33-M300Z-010	
5	SCREW M2*4L K1 NI ICT NY	35-B1120-4R0	

# Appendix B:Schematic Diagrams

This appendix has circuit diagrams of the *M350C/M360C* notebook's PCB's. The following table indicates where to find the appropriate schematic diagram.

Diagram - Page	Diagram - Page
<i>System Block Diagram - Page B - 2</i>	<i>HDD, CDROM - Page B - 17</i>
<i>Socket 479 - 1 of 2 - Page B - 3</i>	<i>LAN RTL8100BL - Page B - 18</i>
<i>Socket 479 - 2 of 2 - Page B - 4</i>	<i>ROM, W517 - Page B - 19</i>
<i>Montara GM-1 - Page B - 5</i>	<i>TI1394 (TSB43AB21) - Page B - 20</i>
<i>Montara GM-2 - Page B - 6</i>	<i>Hitachi H8S - Page B - 21</i>
<i>Montara GM-3 - Page B - 7</i>	<i>CON - Page B - 22</i>
<i>DDRAM - Page B - 8</i>	<i>Audio Codec ALC201 - Page B - 23</i>
<i>DDR Termination - Page B - 9</i>	<i>PCMCIA (ENE1410) - Page B - 24</i>
<i>Clock Generator - Page B - 10</i>	<i>PCMCIA Socket - Page B - 25</i>
<i>LVDS; CRT - Page B - 11</i>	<i>AC IN; Power Button - Page B - 26</i>
<i>ICH4-1 (1 of 3) - Page B - 12</i>	<i>CH7011; TV-Out - Page B - 27</i>
<i>ICH4-2 (2 of 3) - Page B - 13</i>	<i>V_CORE - Page B - 28</i>
<i>ICH4-3 (3 of 3) - Page B - 14</i>	<i>Charger - Page B - 29</i>
<i>USB 2.0, Wireless LAN - Page B - 15</i>	<i>Multi-Function Board - Page B - 30</i>
<i>MDC, BT, CCT - Page B - 16</i>	

*Table 1*  
Schematic  
Diagrams



# System Block Diagram

Sheet 1 of 29  
System Block  
Diagram

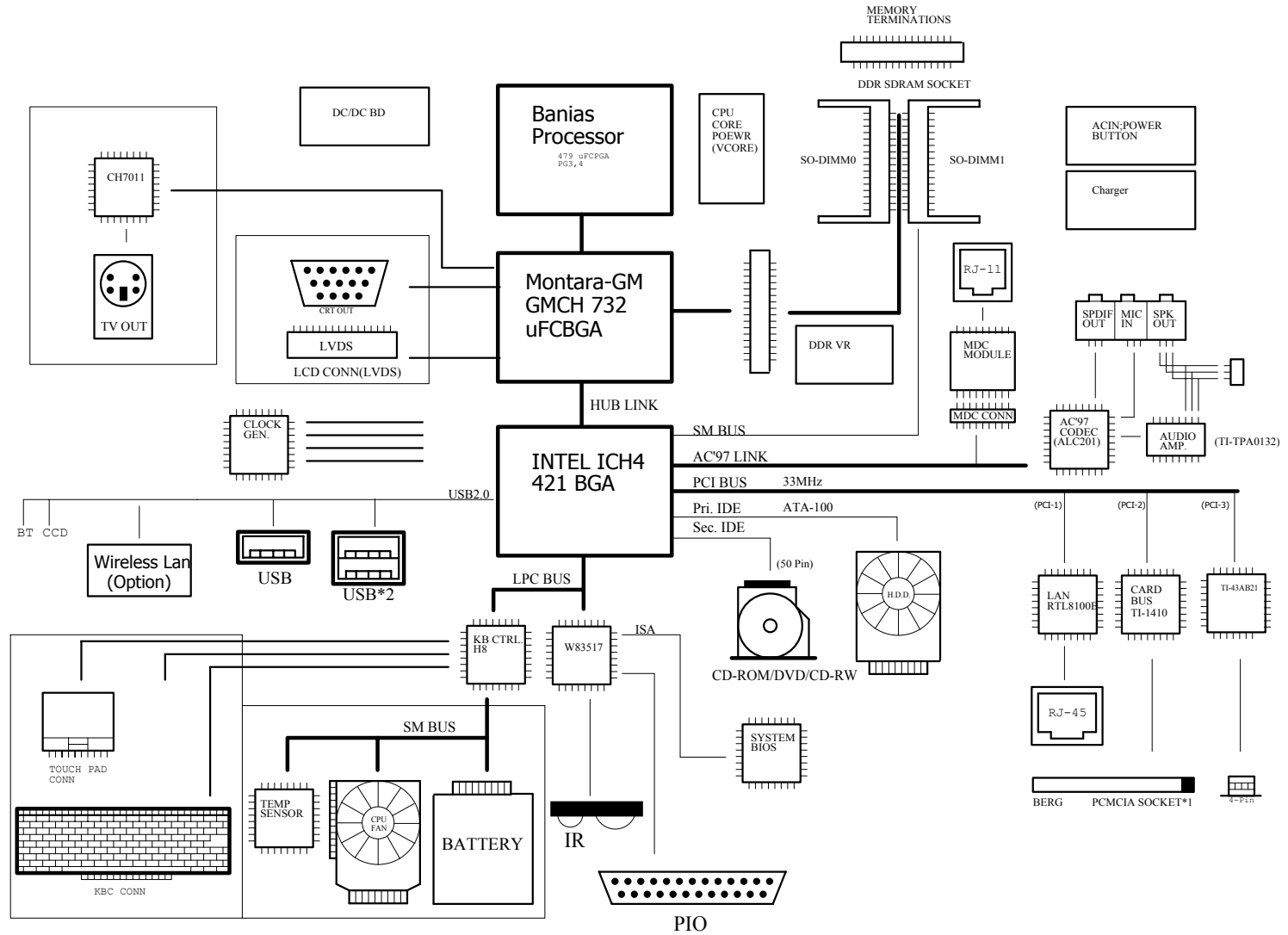



# Socket 479 - 2 of 2

Sheet 3 of 29  
Socket 478  
2 of 2

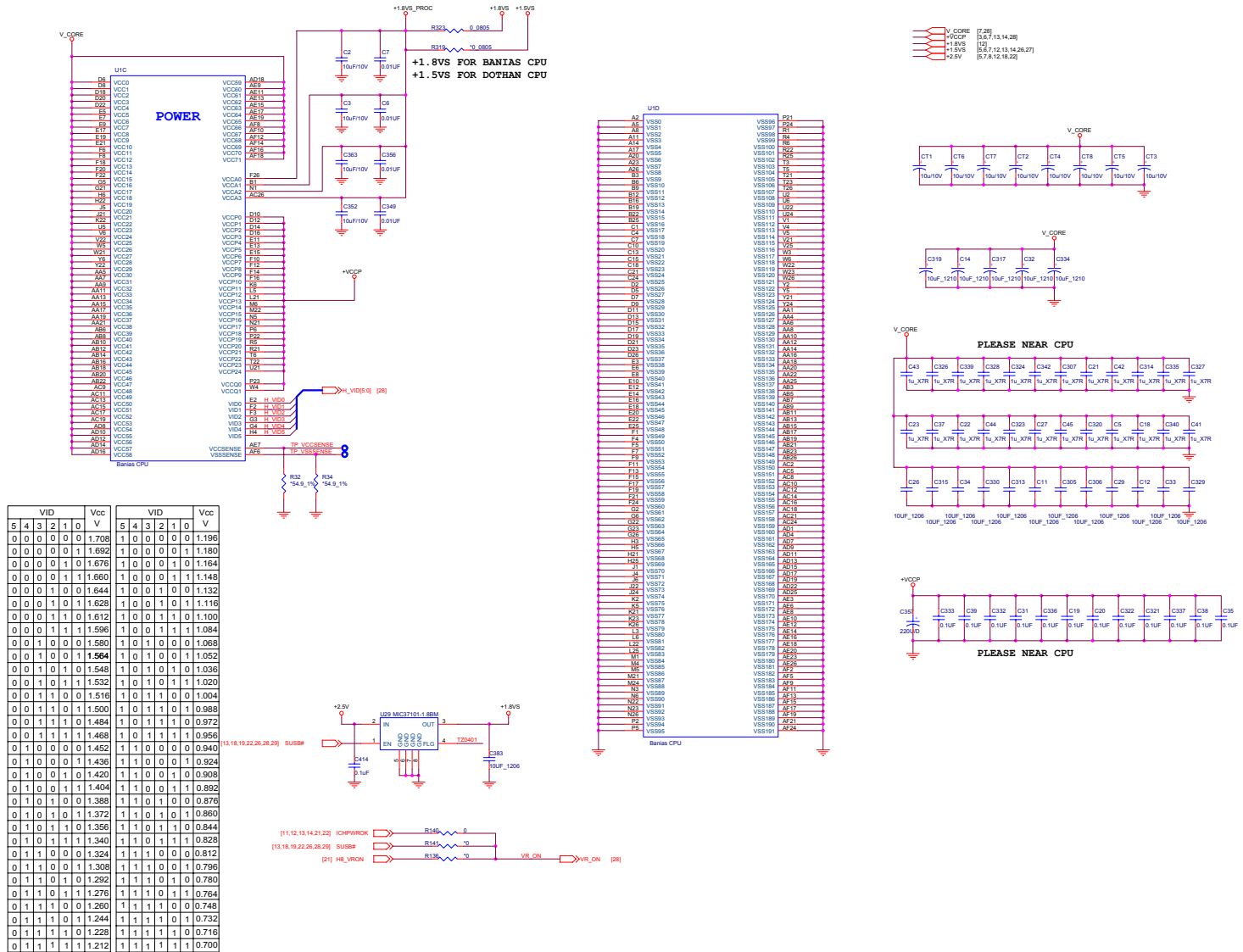

# Montara GM-1

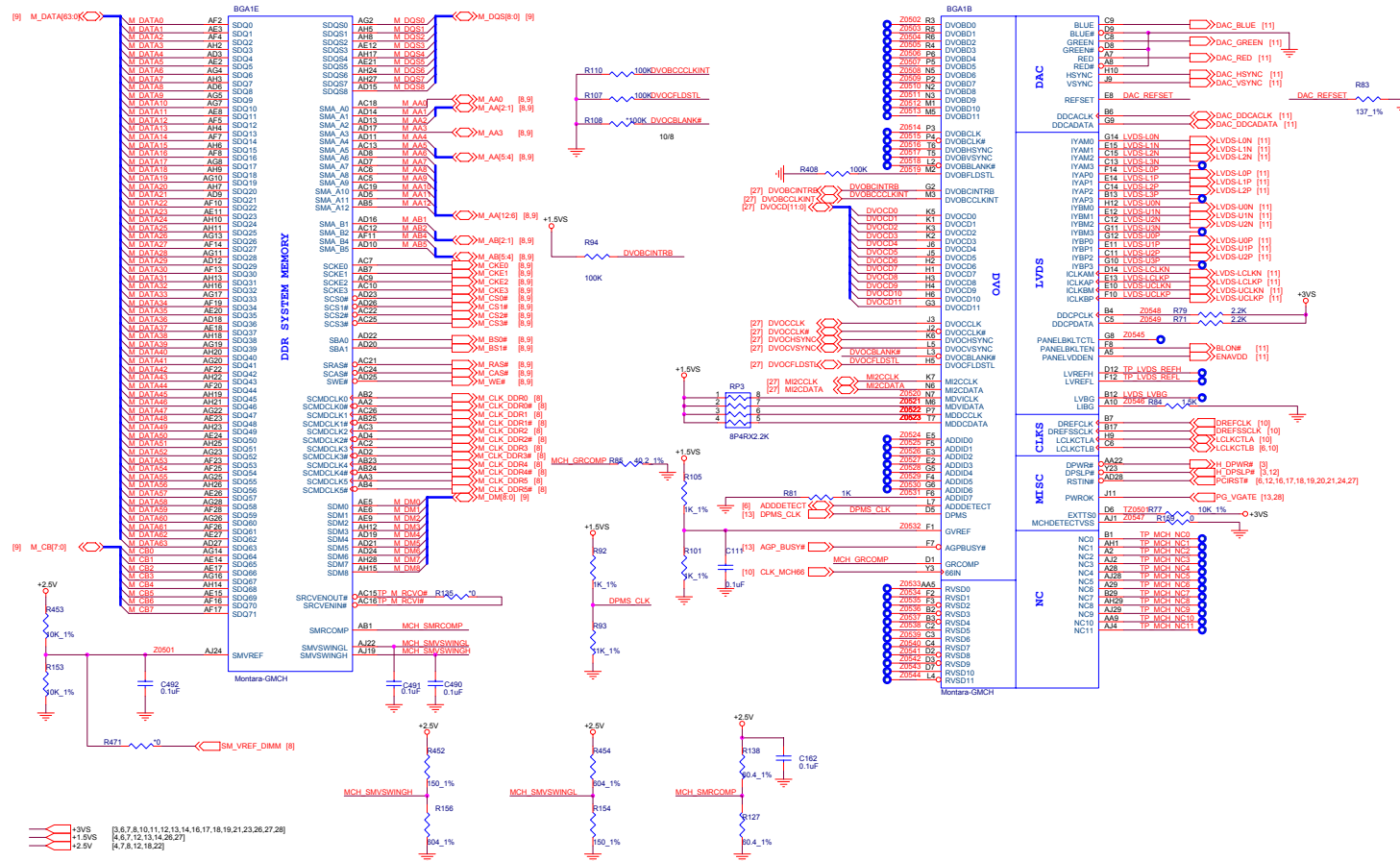

Sheet 4 of 29  
Montara GM-1

B. Schematic Diagrams

# Schematic Diagrams

## Montara GM-2

B.Schematic Diagrams

Sheet 5 of 29  
Montara GM-2

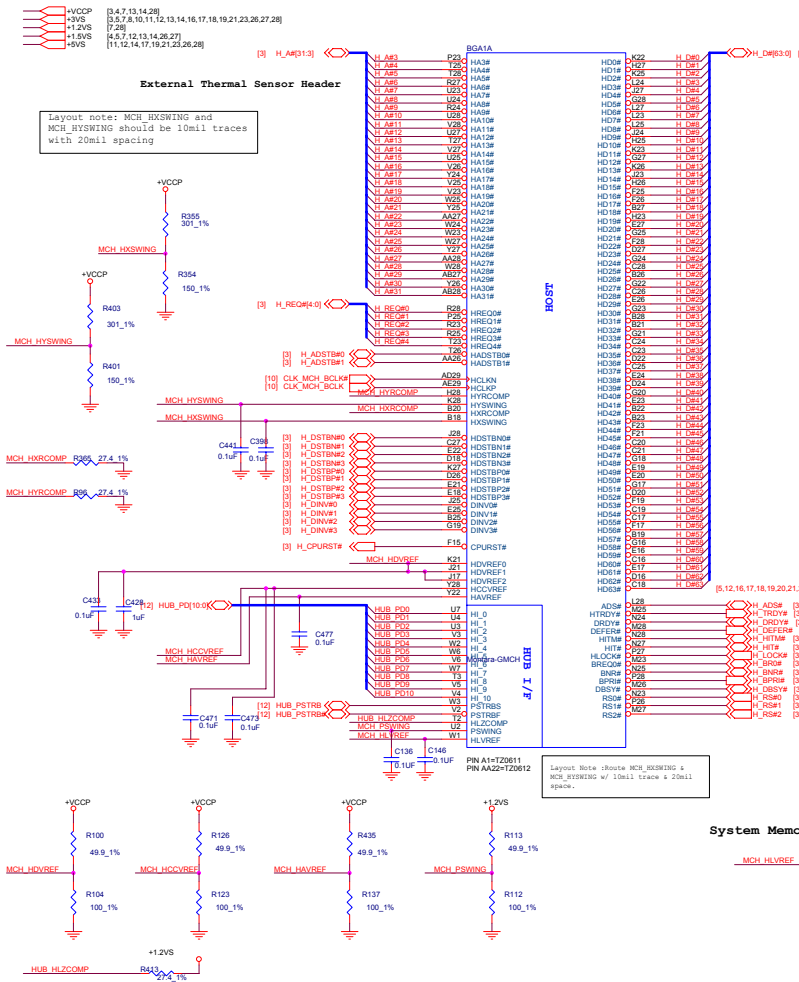

	FUNCTION	Board Default	Optional Override
R56	PSB Voltage Select	No JMP for 1.2VS	1.05V
R57	DVO Strap	No JMP for DVO	RESERVED
R58	CLOCK Configuration	NO JMP	
R59		NO JMP	
R60	Straps	NO JMP	

### GMCH Strapping Options

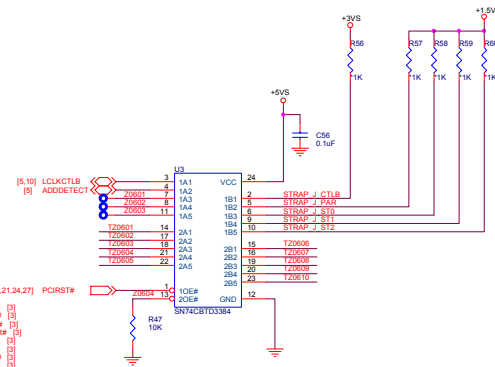

# Montara GM-3

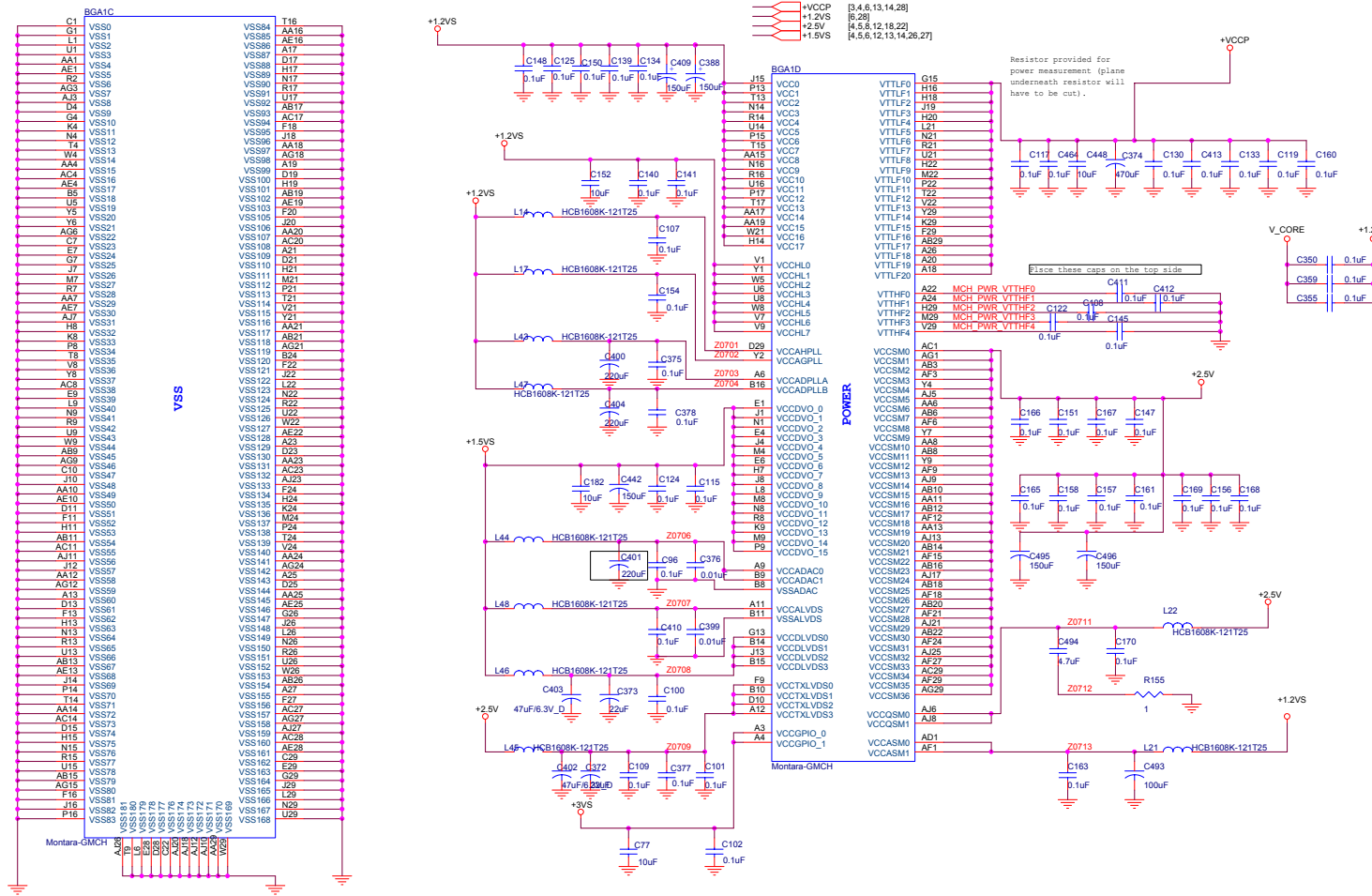

Sheet 6 of 29  
Montara GM-3

B. Schematic Diagrams

# Schematic Diagrams

## DDR4M

Sheet 7 of 29  
DDR4M

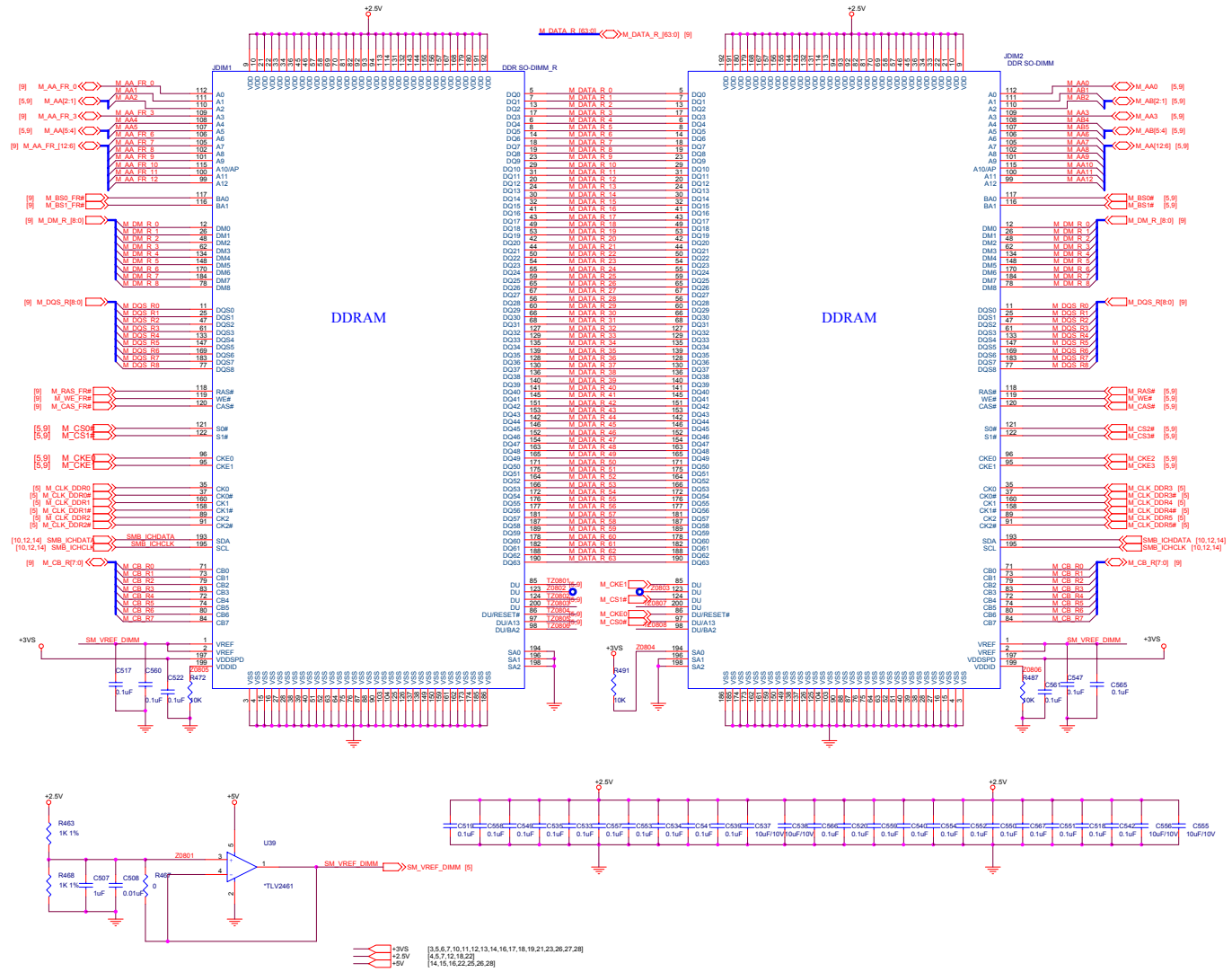

B - 8 DDR4M (71-M3500-D02)

# DDR Termination

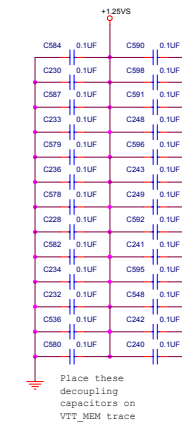
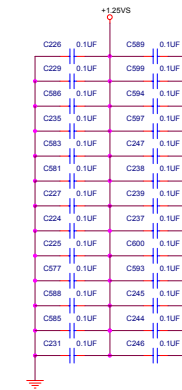
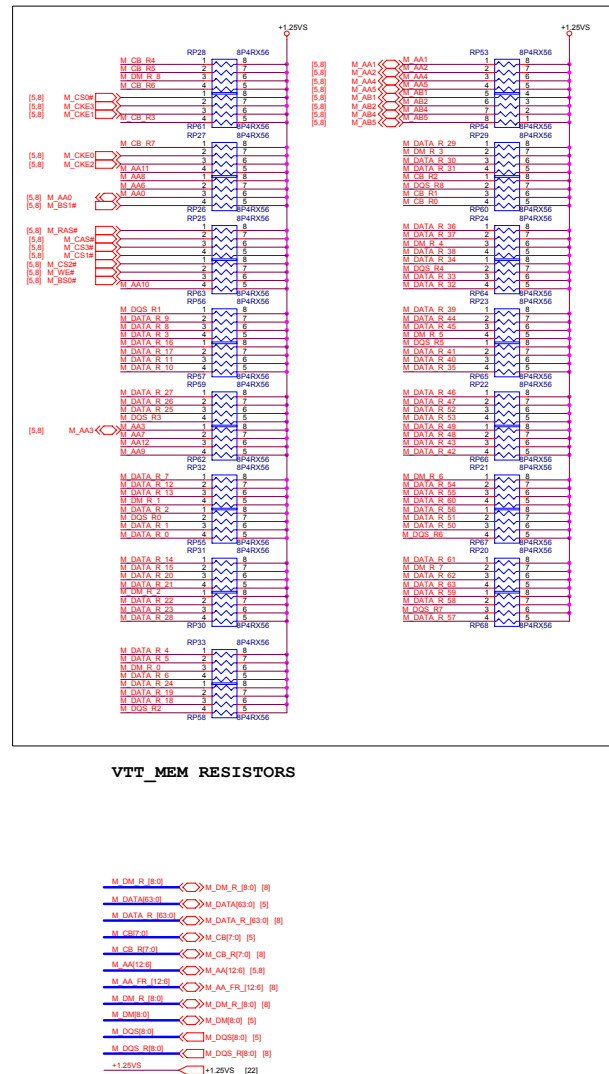
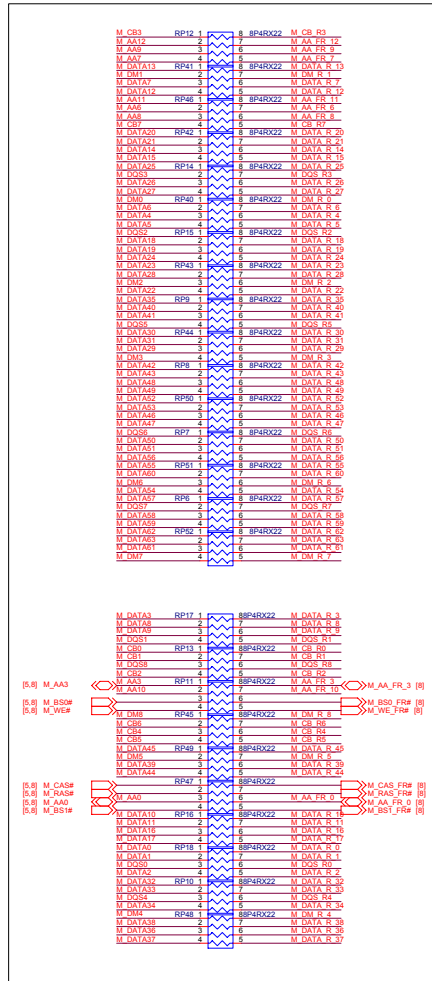

Sheet 8 of 29  
DDR Termination



# Schematic Diagrams

## Clock Generator

+3VS [3,5,6,7,8,11,12,13,14,16,17,18,19,21,23,26,27,28]

FREQUENCY SETUP TABLE							
(FS2)	(FS1)	(FS0)	CPU (MHz)	3V66 (MHz)	66MHz OUT (MHz)	PCI (MHz)	
0	0	0	66.66	66.66	66.66	33.33	
0	0	1	100	66.66	66.66	33.33	
0	1	0	200	66.66	66.66	33.33	
0	1	1	133	66.66	66.66	33.33	
1	0	0	66.66	66.66	66MHz_IN	66MHz_IN2	
1	0	1	100	66.66	66MHz_IN	66MHz_IN2	
1	1	0	200	66.66	66MHz_IN	66MHz_IN2	
1	1	1	133	66.66	66MHz_IN	66MHz_IN2	
Mid	0	0					
Mid	0	1					
Mid	1	0					
Mid	1	1					

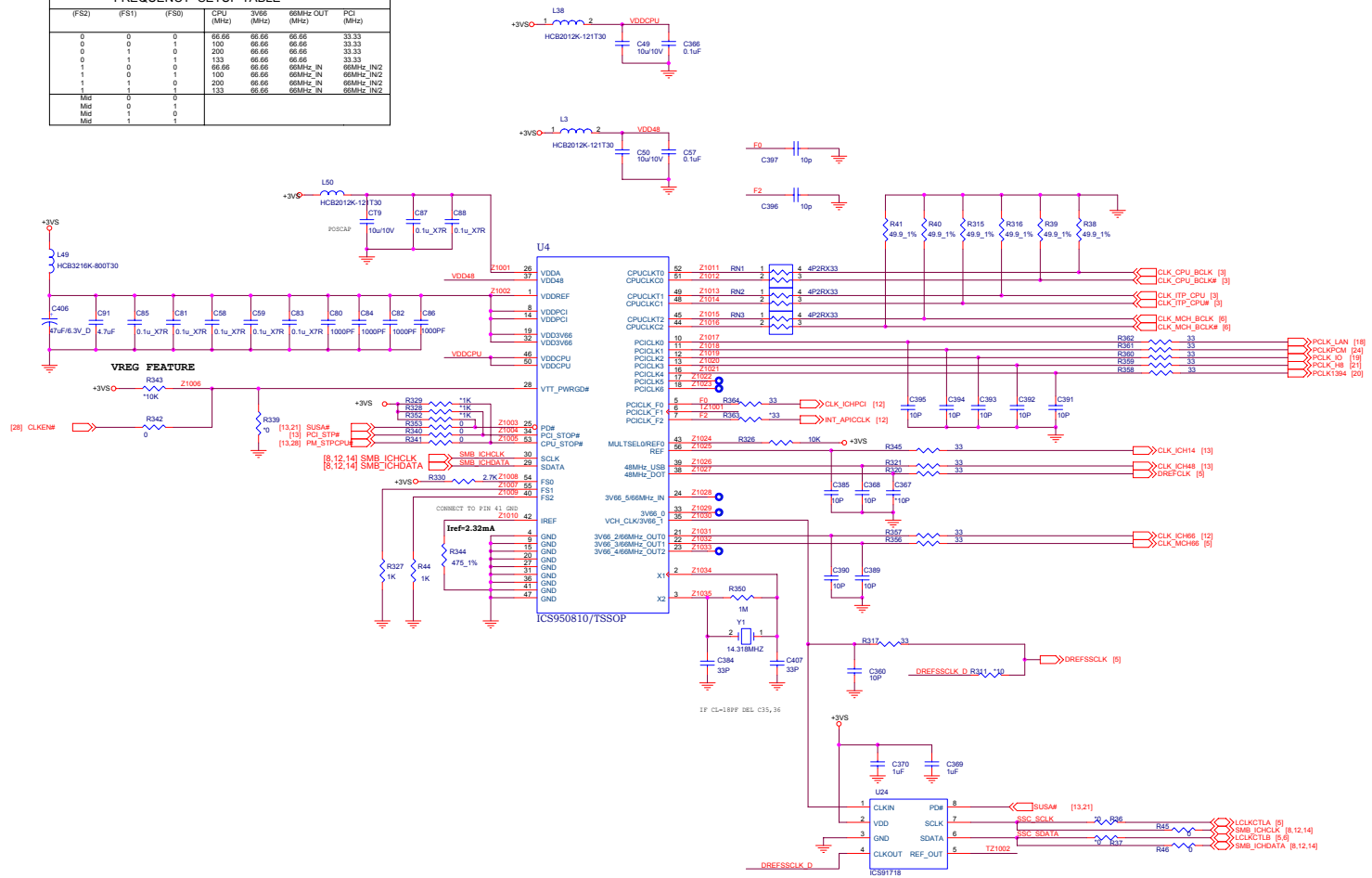

B.Schematic Diagrams

Sheet 9 of 29  
Clock Generator



# ICH4-1 (1 of 3)

Sheet 11 of 29  
**ICH4-1**  
 (1 of 3)

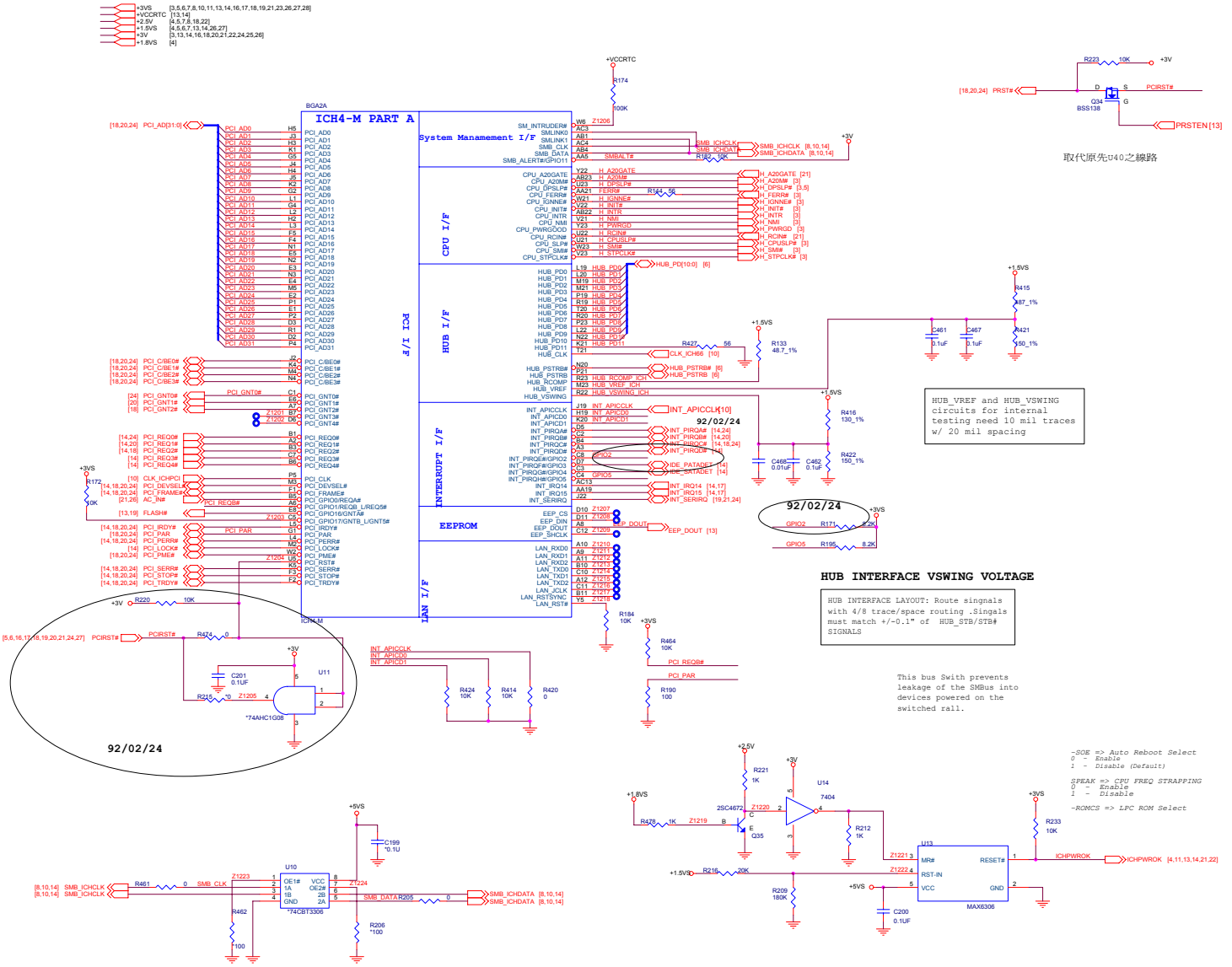

# ICH4-2 (2 of 3)

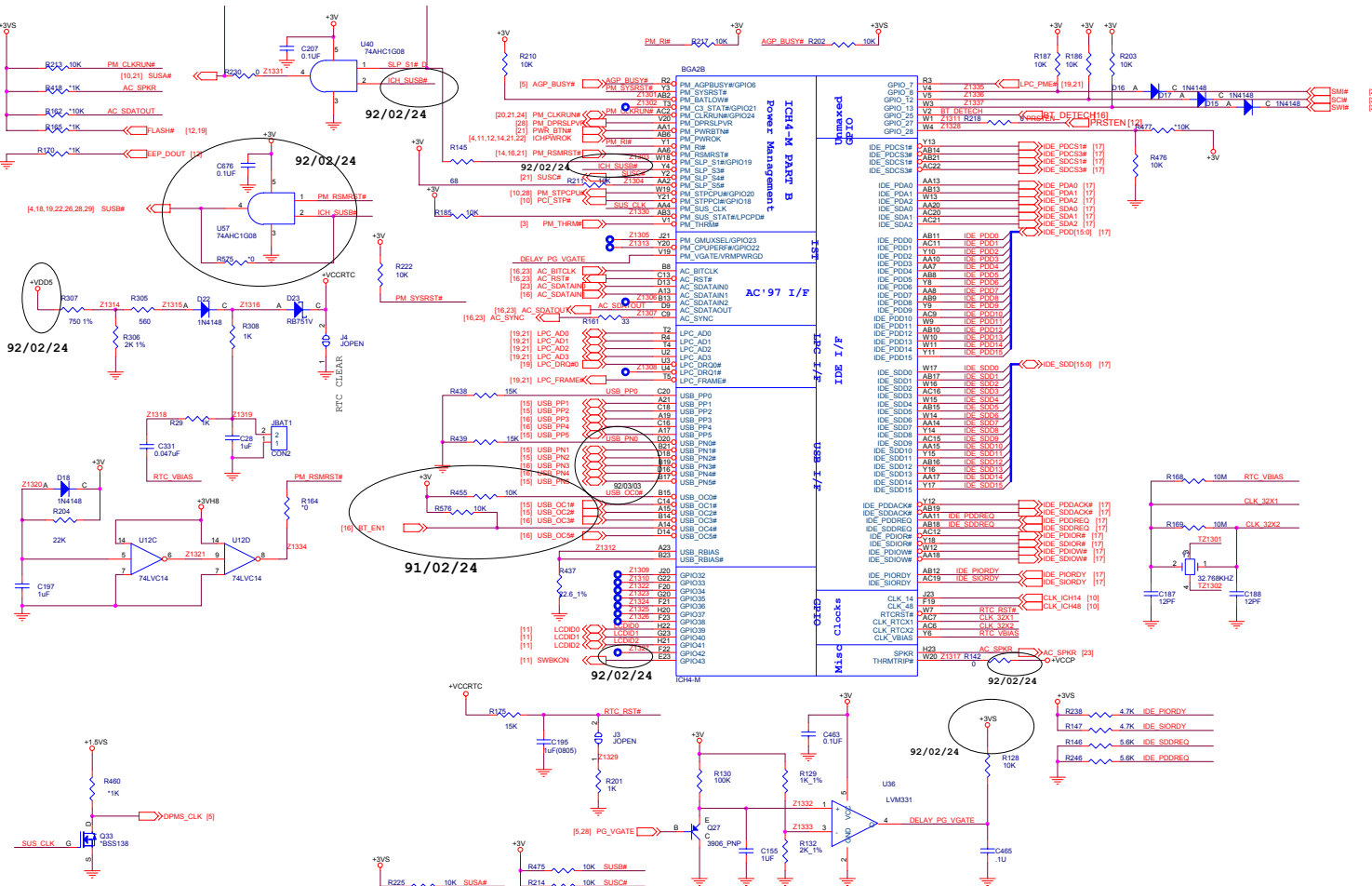

Sheet 12 of 29  
ICH4-2  
(2 of 3)

B.Schematic Diagrams

# Schematic Diagrams

## ICH4-3 (3 of 3)

B.Schematic Diagrams

Sheet 13 of 29  
ICH4-3  
(3 of 3)

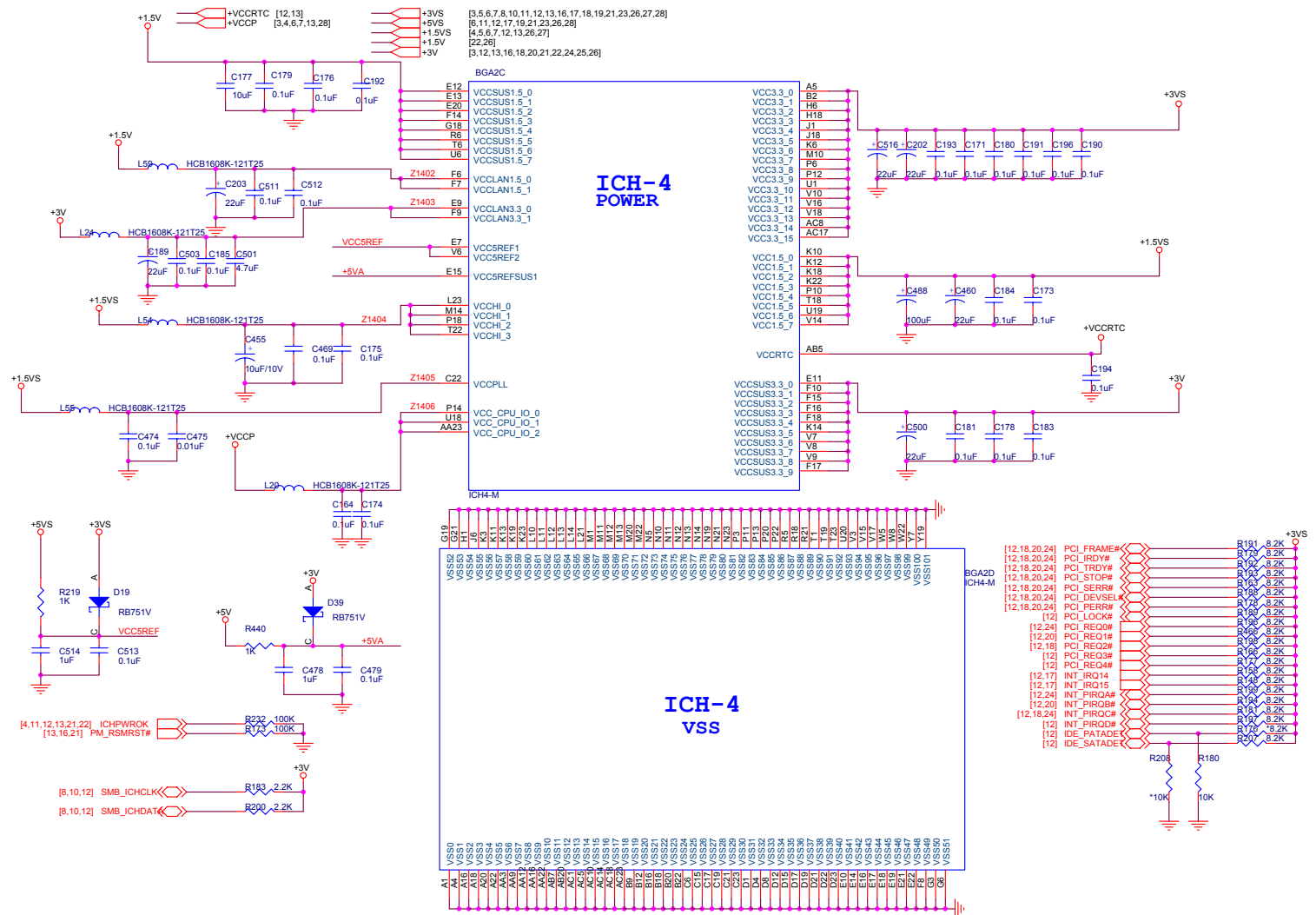

# USB 2.0, Wireless LAN

+3V/S [3,5,6,7,8,10,11,12,13,14,16,17,18,19,21,23,26,27,28]  
 +5V/S [6,11,12,14,17,19,21,23,26,28]

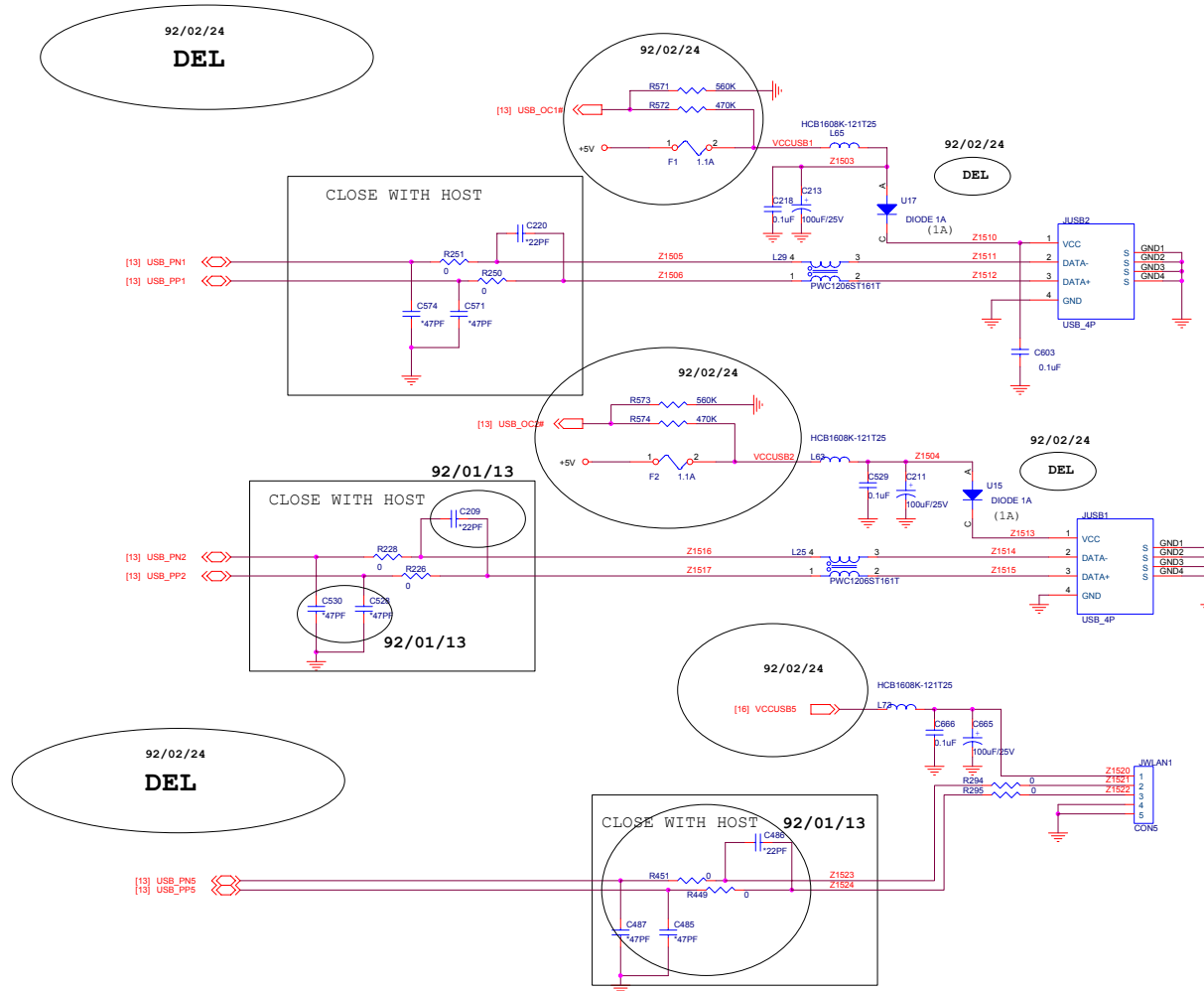

Sheet 14 of 29  
 USB 2.0,  
 Wireless LAN

Schematic Diagrams

MDC, BT, CCT

B.Schematic Diagrams

Sheet 15 of 29  
MDC, BT, CCT

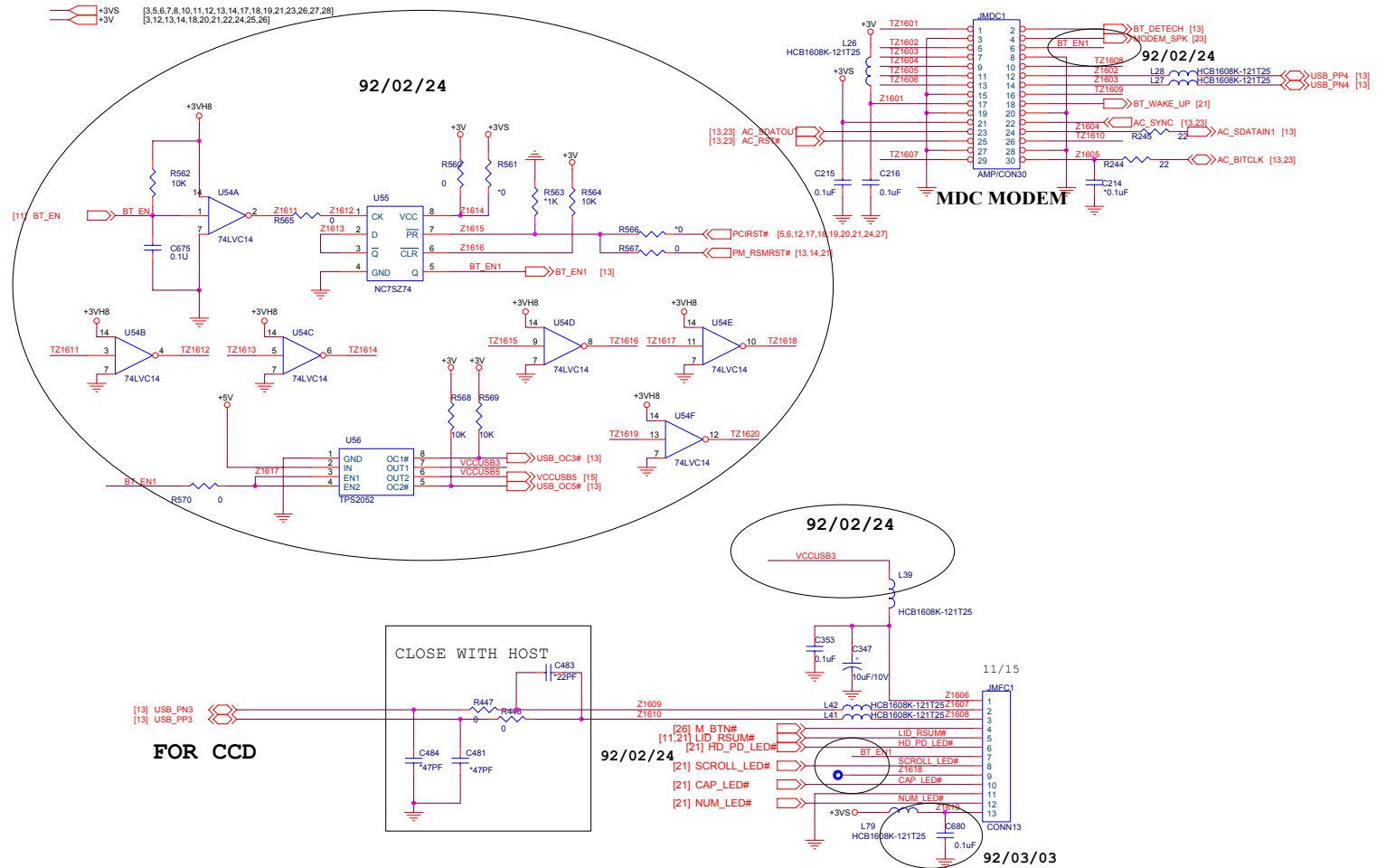

# HDD, CDROM

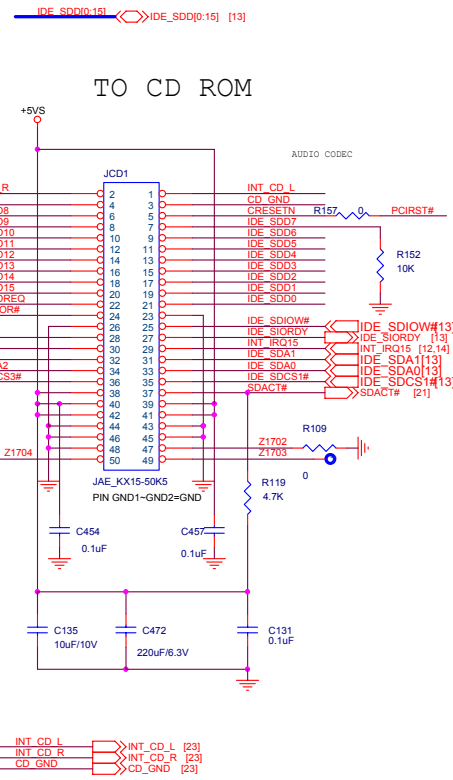
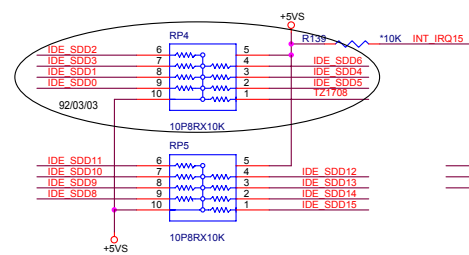
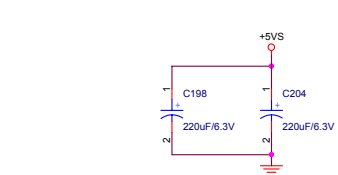
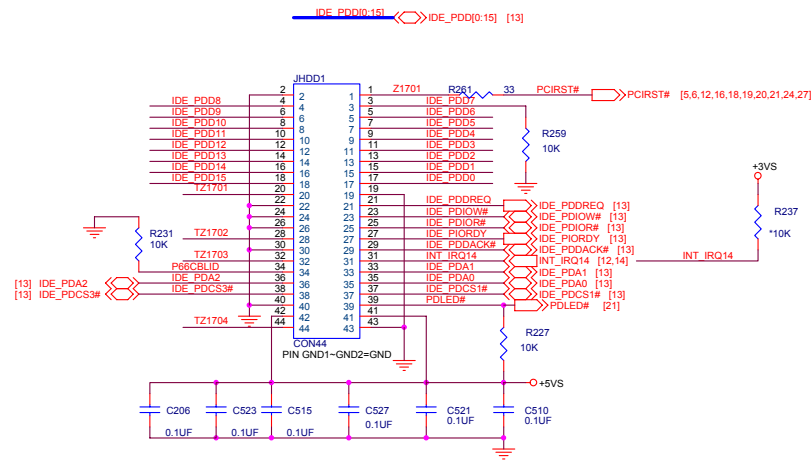
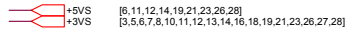

Sheet 16 of 29  
 HDD, CDROM

B. Schematic Diagrams



# Schematic Diagrams

## LAN RTL8100BL

Sheet 17 of 29  
LAN RTL8100BL

±2.5V [4,5,7,8,12,22]  
±3V [5,12,13,14,16,20,21,22,24,25,26]

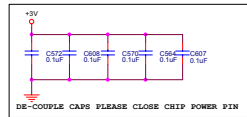

\*For RTL8100C application, all bead must be rated 300mA/100ohm@100kHz  
The maximum voltage drop when on should be less than 0.3V

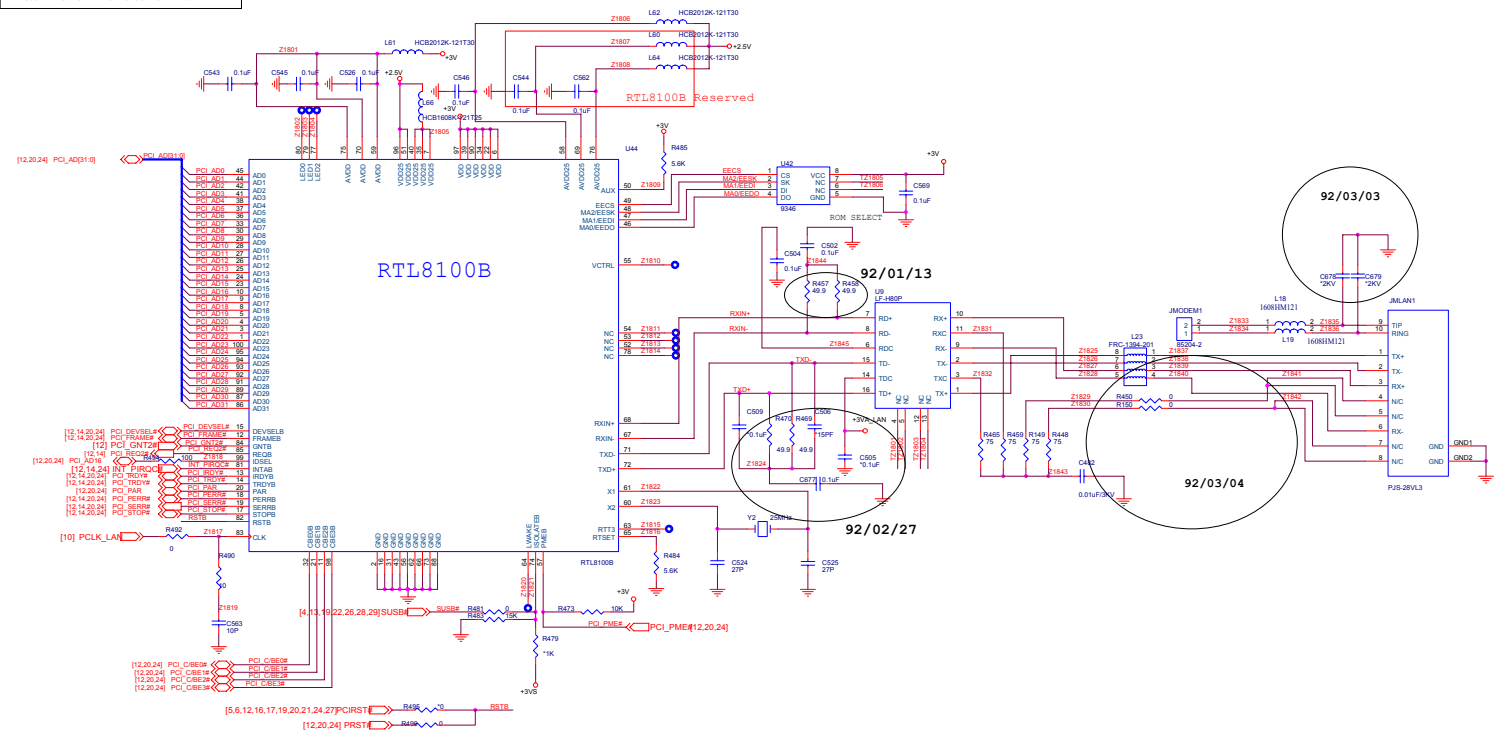

# ROM, W517

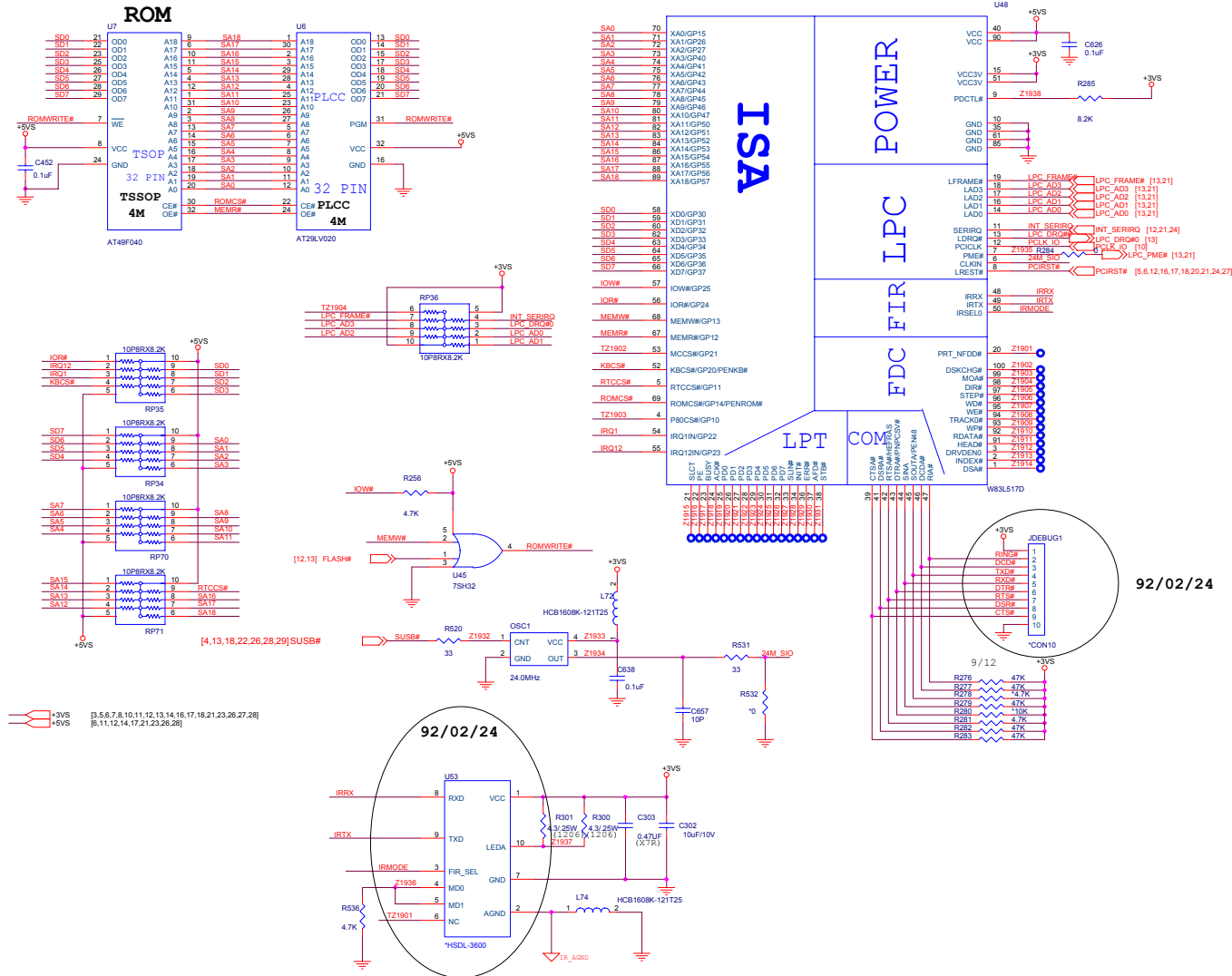

Sheet 18 of 29  
ROM, W517

B. Schematic Diagrams



# Hitachi H8S

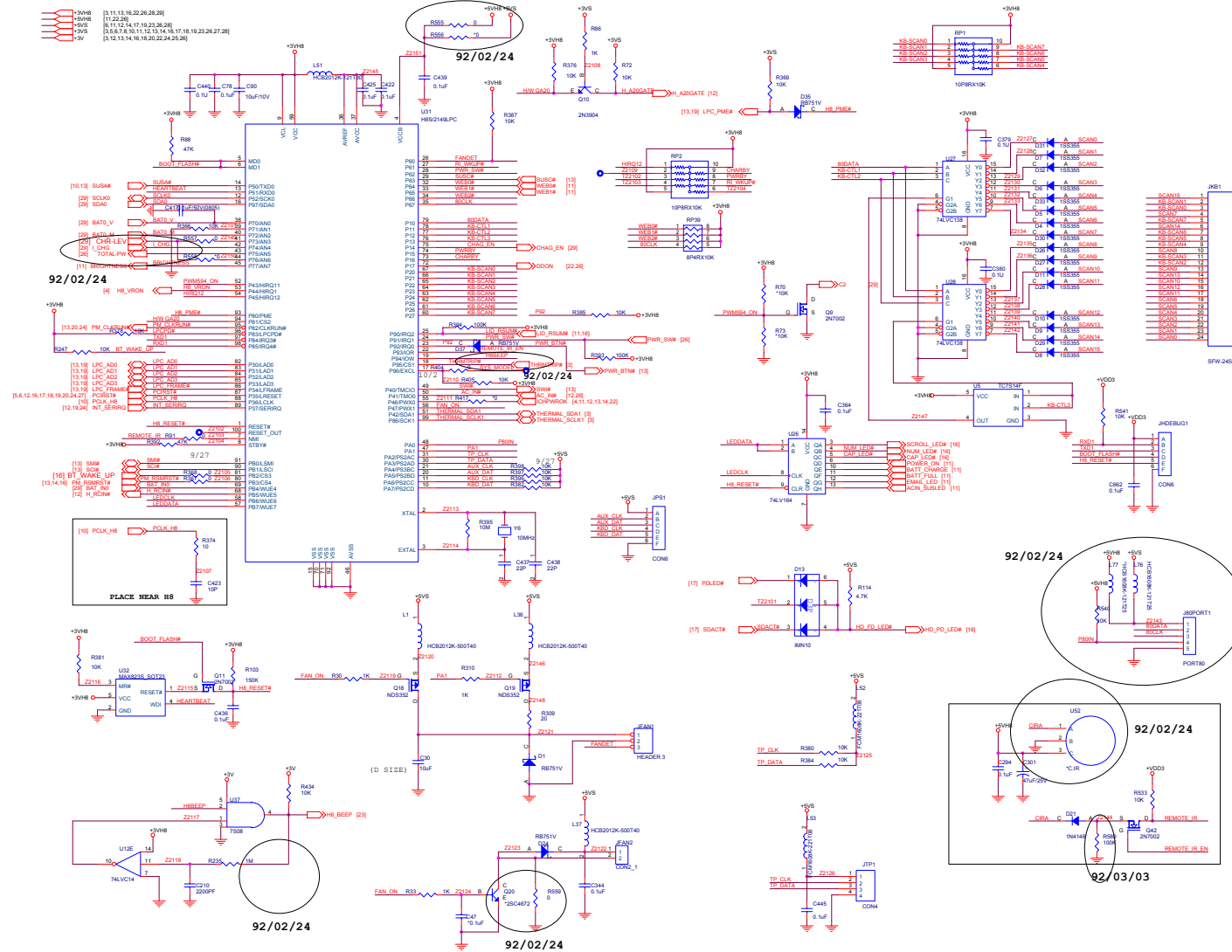

Sheet 20 of 29  
Hitachi H8S

B.Schematic Diagrams

# CON

Sheet 21 of 29  
CON

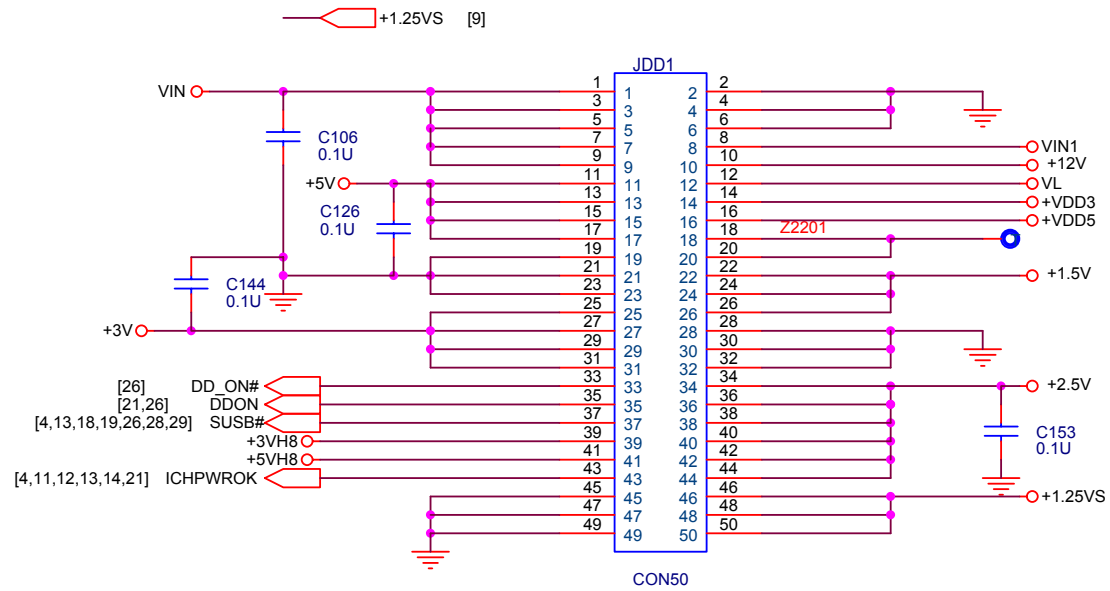

# Audio Codec ALC201

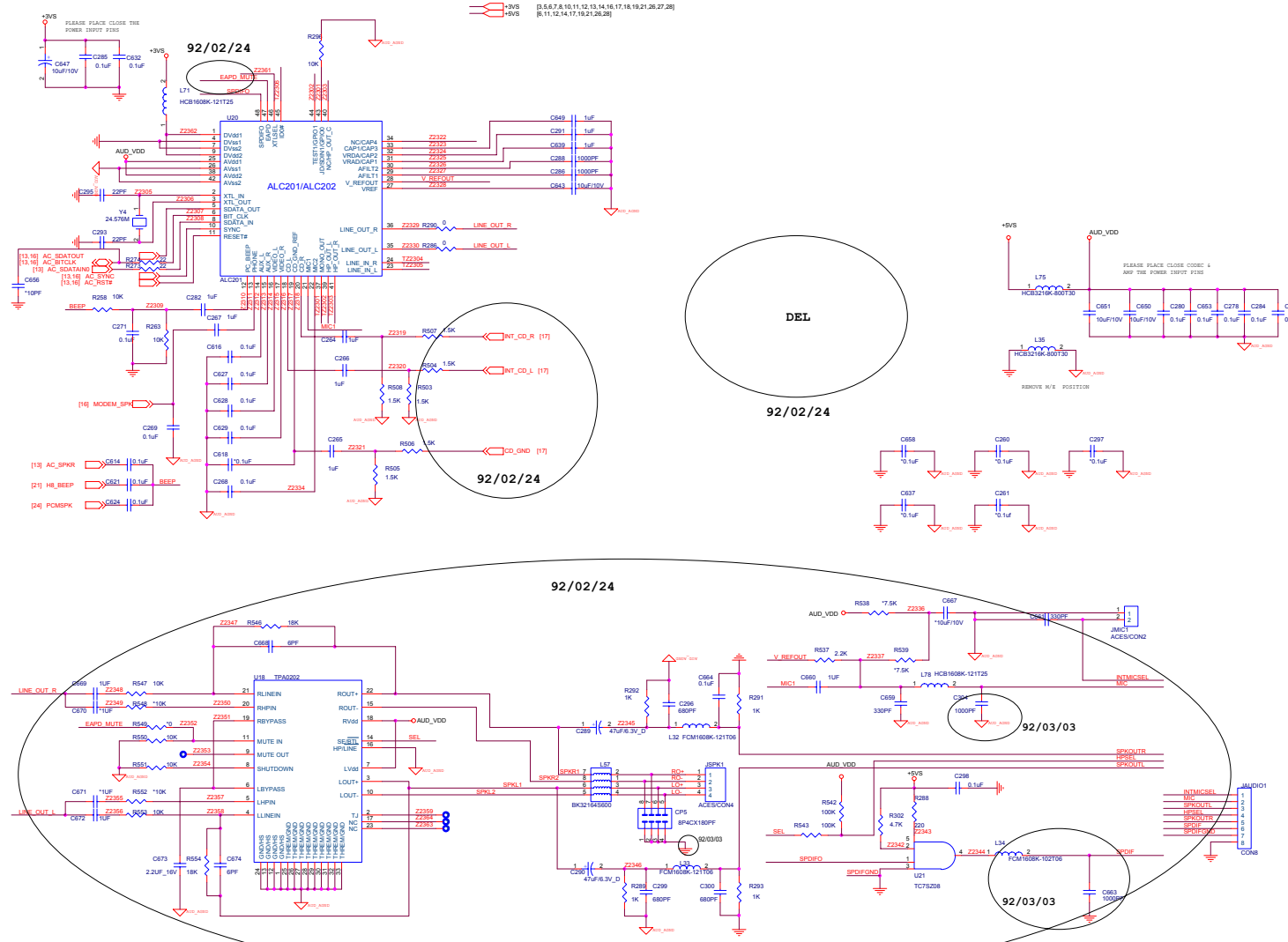

Sheet 22 of 29  
Audio Codec  
ALC201

# PCMCIA (ENE1410)

3V [3,12,13,14,16,18,20,21,22,25,26]

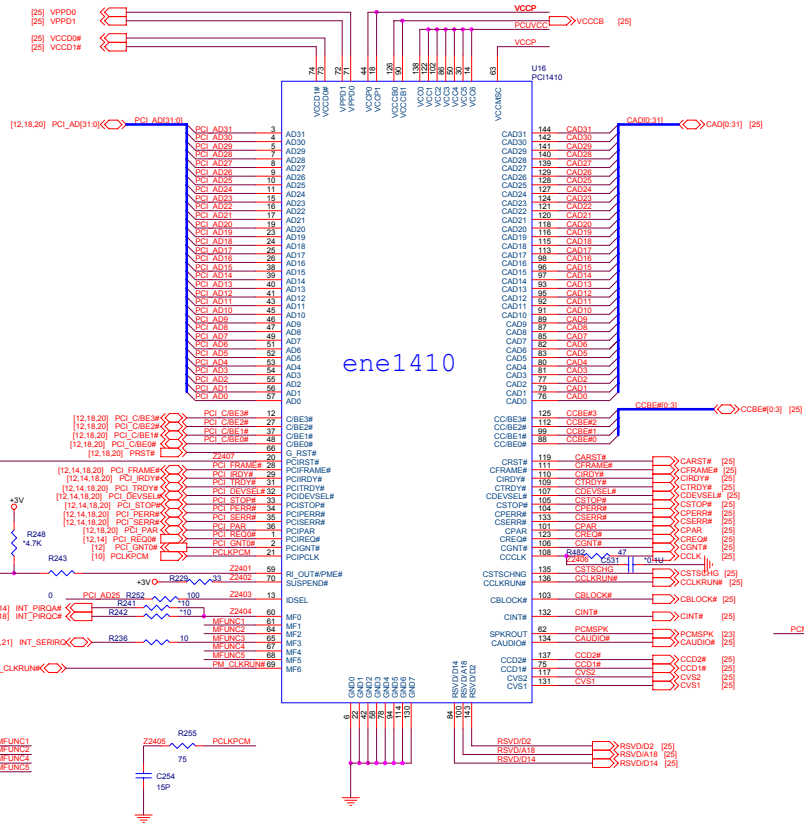
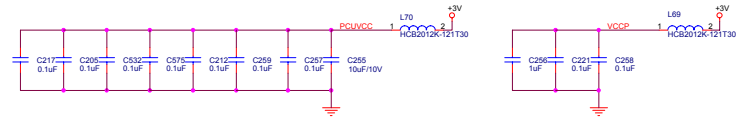

92/02/24  
 [6,12,16,17,18,19,20,21,27] PCIRST# R254 0  
 [12,18,20] PRST# R253 10

B.Schematic Diagrams

Sheet 23 of 29  
 PCMCIA (ENE1410)

# PCMCIA Socket

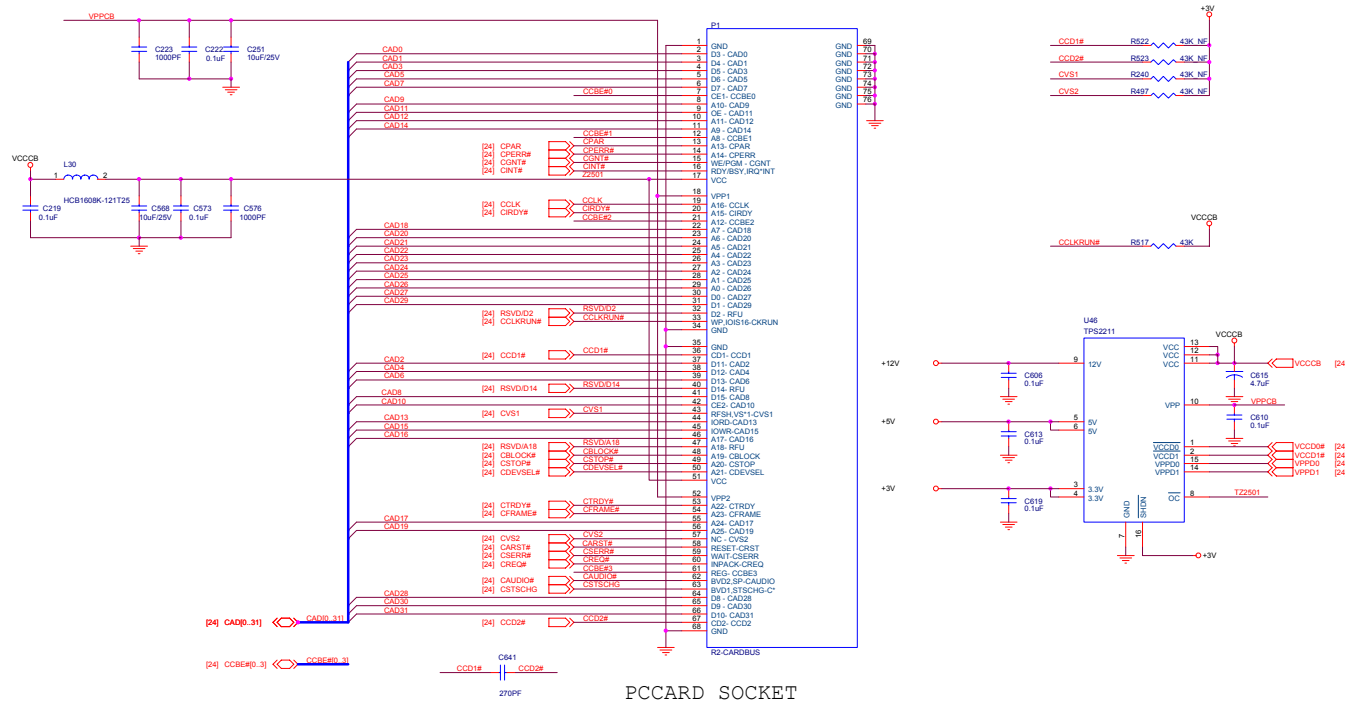
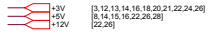

Sheet 24 of 29  
PCMCIA Socket

B.Schematic Diagrams



# AC IN; Power Button

Sheet 25 of 29  
AC IN; Power Button

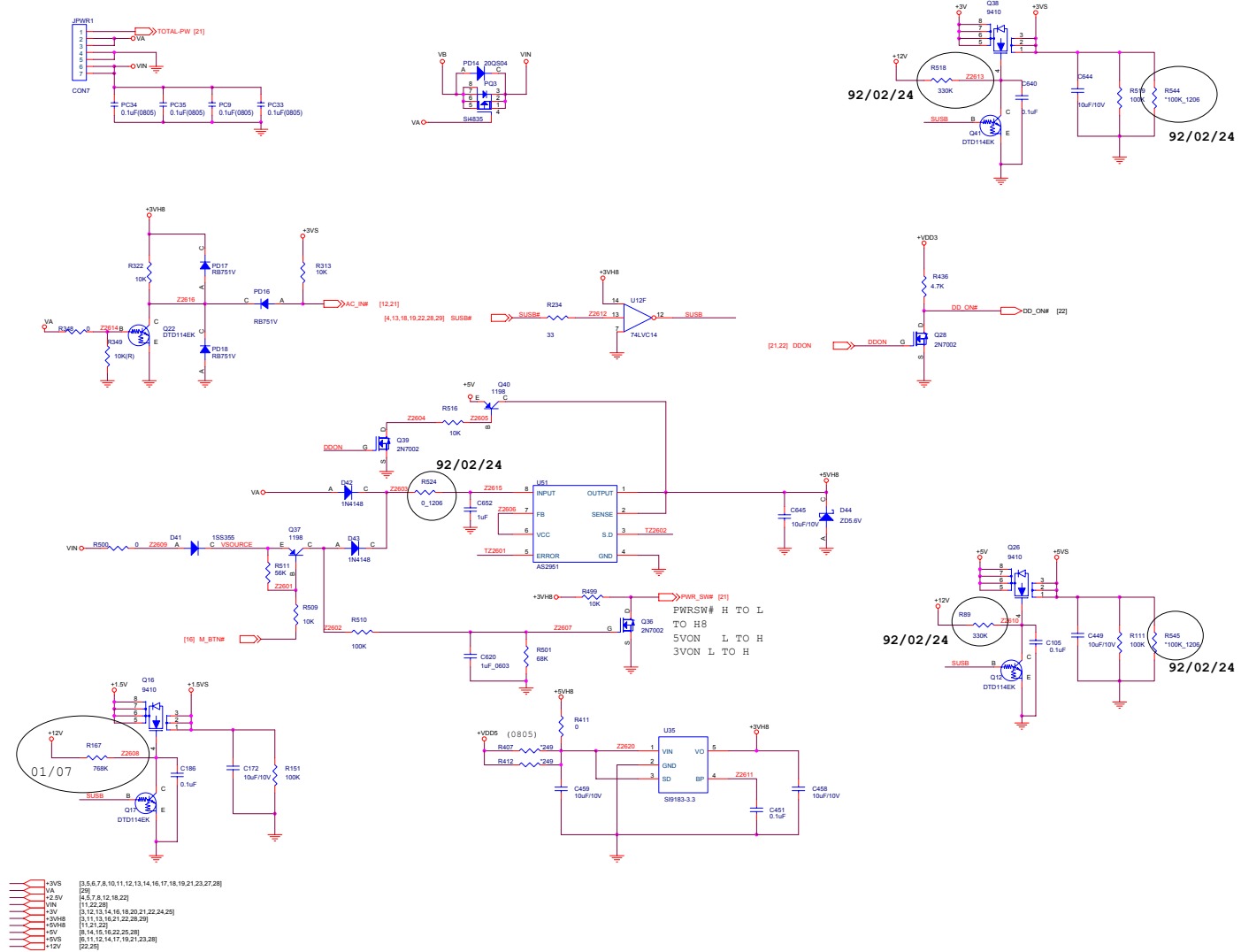

# CH7011; TV-Out

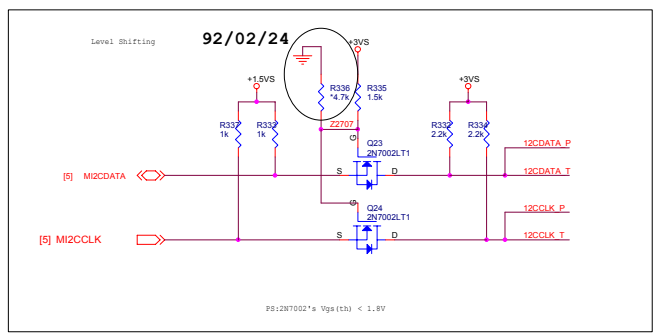
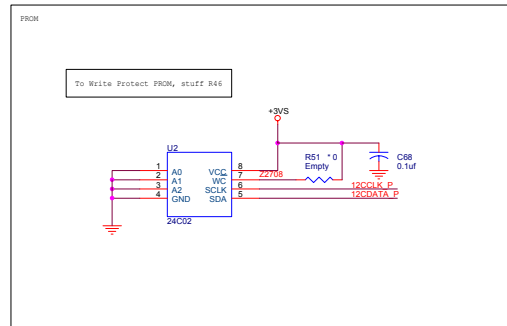
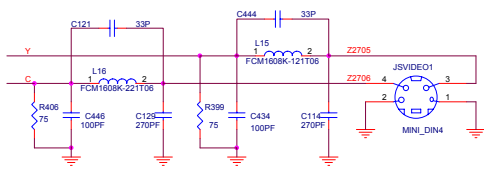
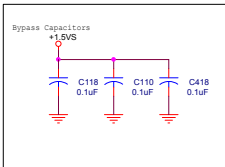
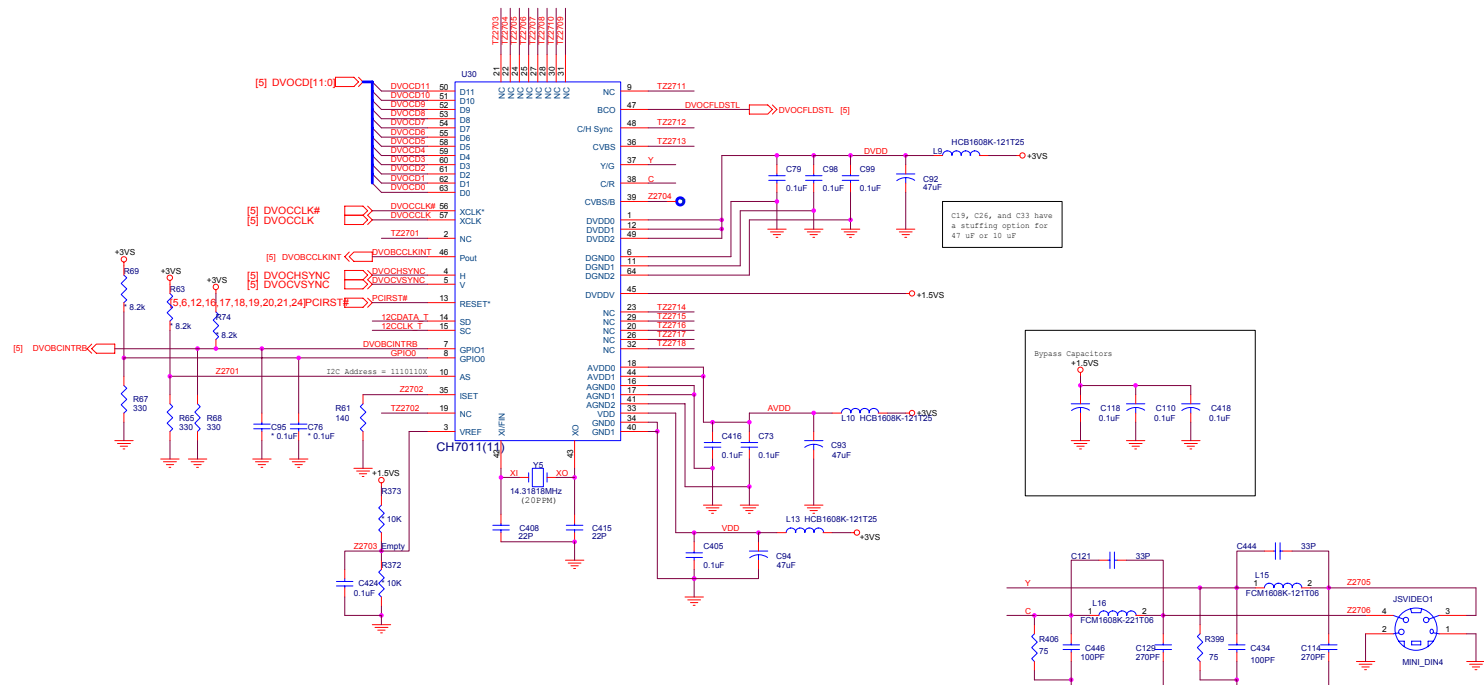

Sheet 26 of 29  
CH7011; TV-Out

B.Schematic Diagrams

# Schematic Diagrams

## V\_CORE

V_CORE	[4,7]
+VCCP	[3,4,6,7,13,14]
+1.2VS	[6,7,12,14,17,19,21,23,28]
+VS	[3,5,6,7,8,10,11,12,13,14,16,17,18,19,21,23,26,27]
+3VS	[5,11,13,16,21,22,26,29]
VIN	[11,22,26]

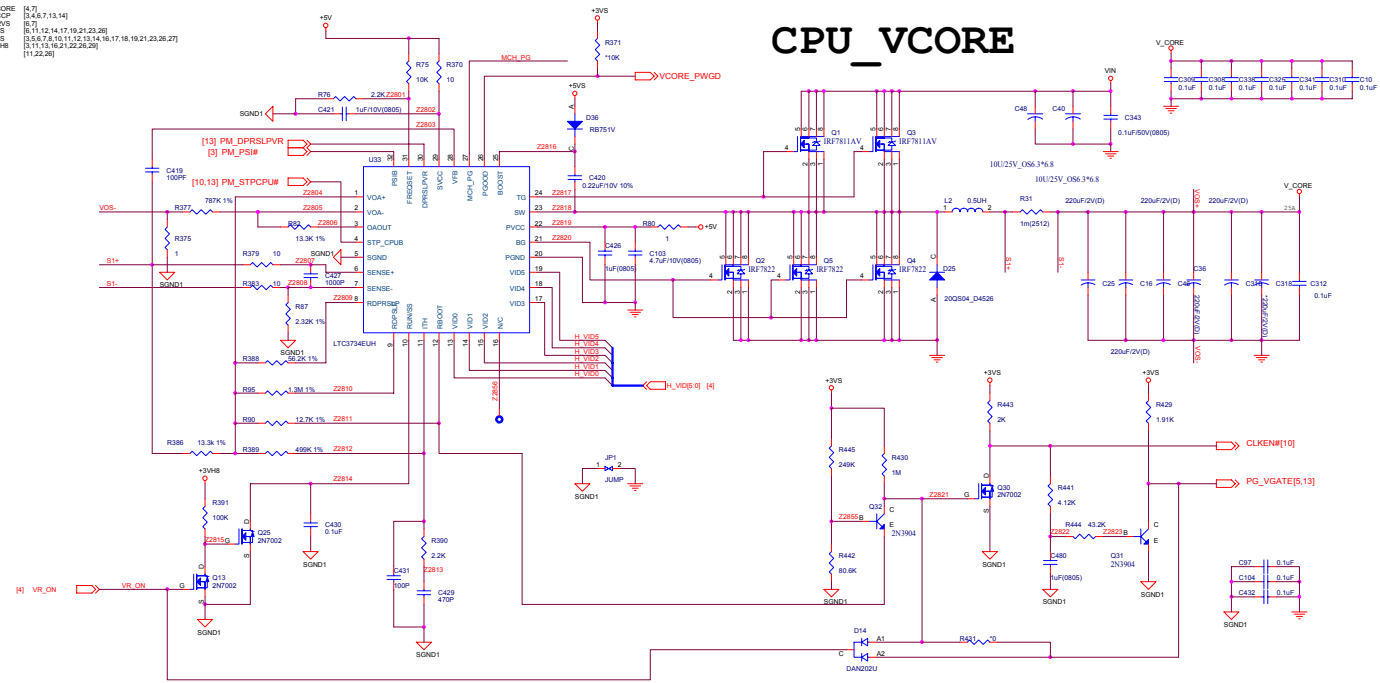

Sheet 27 of 29  
V\_CORE

B.Schematic Diagrams

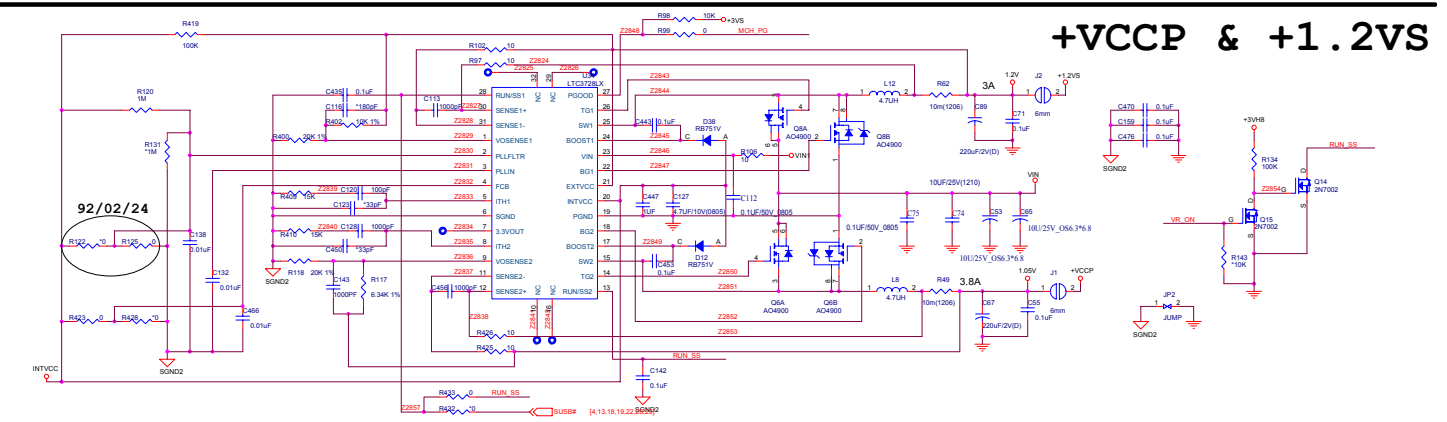

# Charger

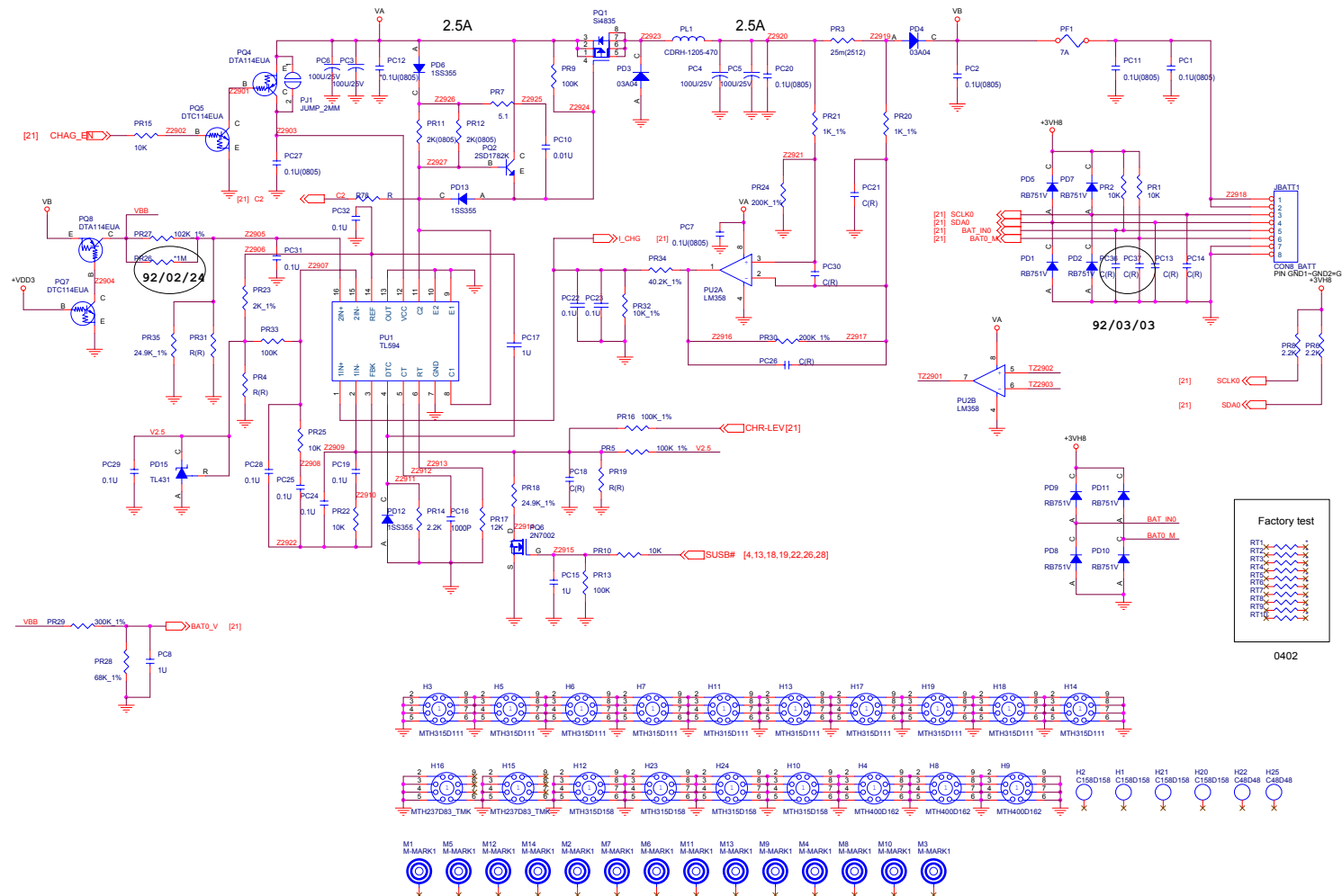

Sheet 28 of 29  
Charger

Factory test	
RT1	X
RT2	X
RT3	X
RT4	X
RT5	X
RT6	X
RT7	X
RT8	X
RT9	X
RT10	X
RT11	X
RT12	X
RT13	X
RT14	X
RT15	X
RT16	X
RT17	X
RT18	X
RT19	X
RT20	X

0402

# Multi-Function Board

Sheet 29 of 29  
Multi-Function  
Board

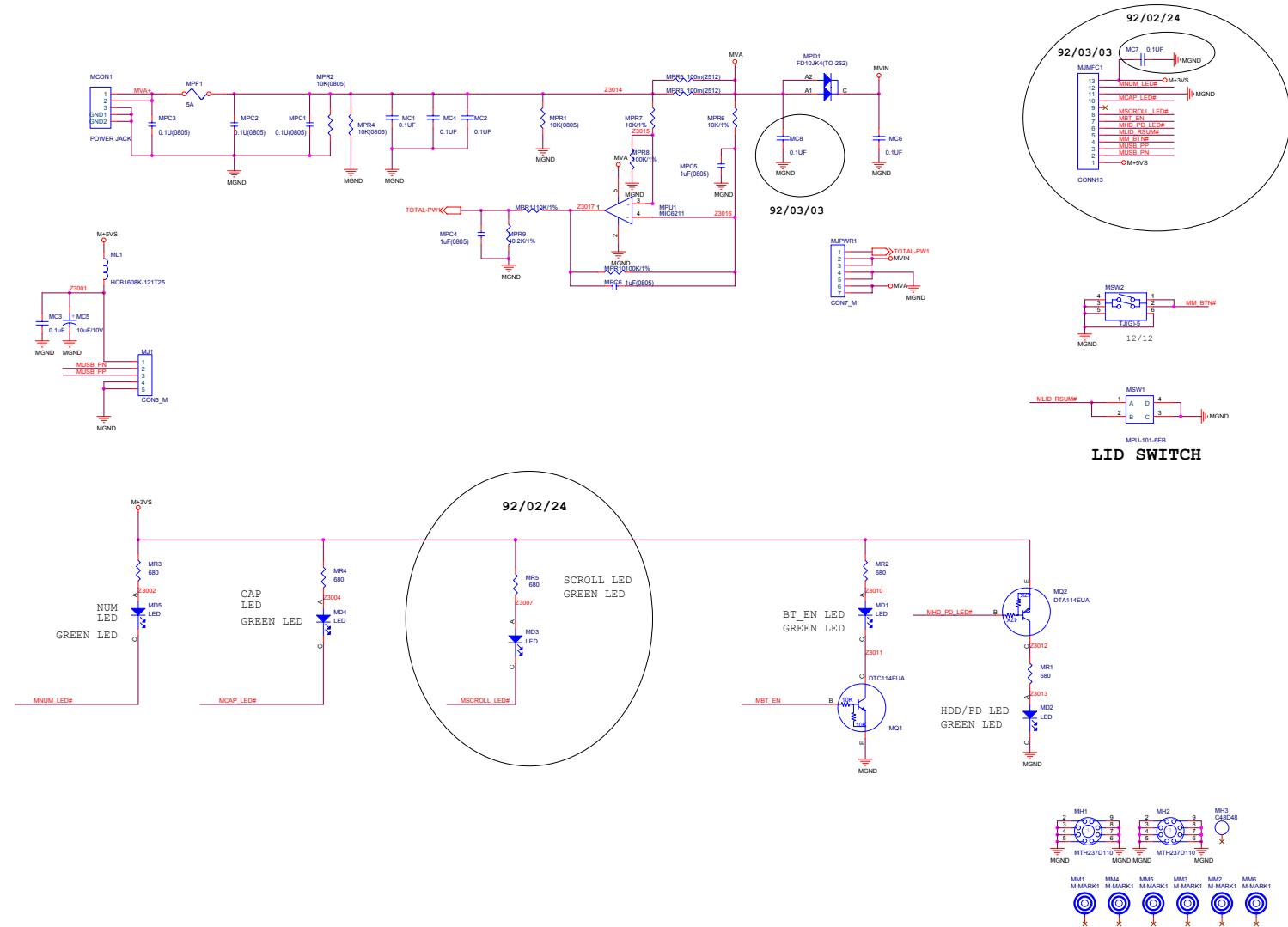

# Appendix C: Updating the FLASH ROM BIOS

## To update the FLASH ROM BIOS you must:

- Download the BIOS update from the web site.
  - Unzip the files onto a bootable Floppy Disk.
  - Reboot your computer from the FDD.
  - Use the flash tools to update the flash BIOS.
  - Restart the computer booting from the HDD.
1. Using your web browser go to [www.clevo.com.tw](http://www.clevo.com.tw)
  2. Choose **Download** from the menu bar at the top of the page.
  3. In the **Driver** section select the model of your computer (**M350C/M360C Series**) and the driver type (**BIOS**).
  4. Select **GO**.
  5. Click on **M3x0CRxxx.zip** to download the BIOS files (including BIOS refresh tools).

## Unzip the file you have just downloaded on to a bootable floppy disk.

*(The files you should see on this disk are: Flash.exe, Fp.exe, M3x0Rxxx.bin)*

1. With the bootable floppy disk containing the BIOS files in your floppy drive, restart the computer.
2. The BIOS refresh process will execute automatically.
3. Reboot the computer and enter the BIOS setup.
4. Exit the BIOS and restore the default settings by choosing “Save and Exit”.

