

# Notebook PC Service Manual

## Model : 340S8

### Chapter 1 General System Description

#### 1.1 System features

##### 1.1.1 General features

- a. Support cost efficient CPU,
  - Celeron-128K Socket 370 Type FCPGA 500~700 MHz
  - Pentium III Socket 370 Type FCPGA 500~1.0GHz
- b. Superior portability with all in one design
- c. Support high quality audio include 2 internal high power speaker
- d. Fully Support ACPI 1.0, meet PC98/PC99 requirement
- e. Built-in 56K modem for Data/Fax/Voice modem or Internet (optional)
- f. Support high performance hardware 2D/3D graphic engine

- g. Support high capacity memory up to 256 MB
- h. Support one most flexibility of 32-bit Cardbus slot and PCMCIA card

### 1.1.2 Hardware specification

#### A. CPU:

##### **Celeron-128K 500MHz to 700MHz**

- System bus frequency at 66 MHz
- Dynamic execution micro-architecture
- MMX technology capability
- Optimized for 32 bits AP and OS
- Power Management capability
- Integrated 32KB instruction and data L1 cache
- Integrated 128 KB instruction and data L2 cache

##### **Pentium III 500MHz and 1.0 GHz**

- System bus frequency at 100MHz / 133MHz
- On-die 256KB L2 advanced transfer cache with ECC
- Dual independent bus architecture
- SIMD extensions for enhanced video, sound and 3D performance
- Dynamic execution micro architecture
- Power management capability
- Optimized for 32bits AP and OS
- Integrated 16KB instruction and 16KB data L1 cache
- 256bit cache data bus
- 8-way cache associatively
- ECC for system bus data

#### B. Core Logic

##### **SIS 630S**

- Integrated North Bridge, advanced hardware 2D/3D GUI engine, Super South Bridge and a 4X AGP internal
- Integrated Ultra AGP technology and advanced 64-bit graphic display interface and delivers AGP 4X performance and Fast Write transactions
- Provides powerful hardware decoding DVD accelerator to improve DVD playback performance.
- Provides standard interface between PC and a digital flat panel monitor.
- Adopts Share System Memory Architecture which the Super South Bridge in SIS 630S integrates all peripheral controllers /accelerators /interfaces
- Provides total communication solution including 10/100MB Fast Ethernet
- Offers AC'97 compliant interface that comprises digital audio engine with 3D-hardware accelerator, on-chip full duplex sample rate converter
- Provides interface to Low Pin Count (LPC) operating at 33MHz clocks which is the same as the PCI clock on the Host.
- Built-in fast PCI-IDE controller supports the ATA PIO/DMA and ultraDMA33/66/100 functions that supports the data transfer rate up to 100 MB/s

**C. PCMCIA Controller**

**O2 Micro OZ6812**

- ACPI-PCI bus power management interface specification Rev.1.0 compliant
- Compliant with PCI specification V2.1S, 1995 PC Card Standard and JEIDA 4.1
- Supports PCMCIA ATA specification
- Supports 5V/3.3V PC Cards and 3.3V Cardbus Cards
- Supports single PC card or Cardbus slot with hot insertion and removal
- Supports multiple FIFOs for PCI/CB data transfer
- Supports Direct memory access for PC/PCI and PC/Way on PC Card socket
- Win98IRQ and PC-97/98 compliant
- Integrated PC98 Subsystem Vendor ID support with auto lock bit

**D. Embedded Controller / Keyboard Controller**

**NS PC87570**

- Hot key for brightness, volume control
- ACPI controller
- SMB bus for smart battery
- Support Win-95 defined 3 new keys and down load-able key-matrix

**E. Super I/O Controller**

**NS PC87393**

- LPC System Interface with synchronous cycles, up to 33 MHz bus clock
- PC99 and ACPI Compliant
- Floppy Disk Controller (FDC)
- Support SPP, EPP and ECP Parallel port
- Software compatible with the 16550A and the 16450 serial port
- HP-IR, ASK-IR, Fast-IR support

**F. Clock Generator**

**Realtek W83194R-63S**

- Multiple CPU clocks for SDRAM architecture
- Provide power down mode in slowing down CPU clock
- Spectrum modulation reduce EMI
- Provide programmable clocks
- 166MHz Clock Support

**1.2 System Specification**

**1.2.1 System Board**

The major components of the computer include the system board, XGA color LCD display, FDD module, CD-ROM module (24X rotational speed max) / DVD module, keyboard, built-in glide pad with 2 click buttons, Lithium-ION battery pack, and AC adapter.

The system board incorporates CPU module, system memory, system and VGA BIOS, audio controller, CPU/ PCI bus controller, PCI/ ISA bus controller. The

System Block Diagram shows how these components are integrated as shown in the next page.

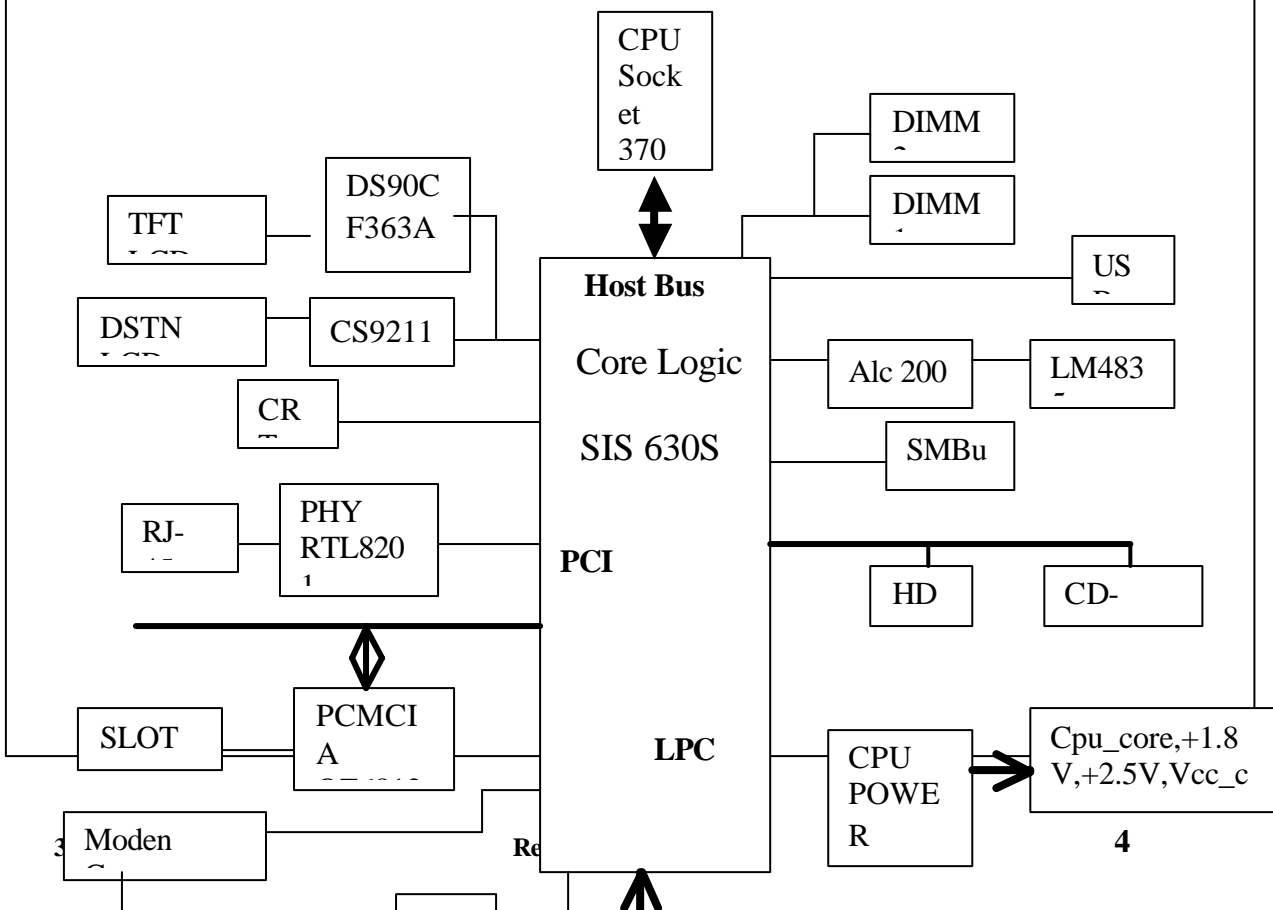

### 1.2.2 LCD Display

14.1" TFT

13.3" TFT

12.1" TFT

### 1.2.3 Power Plans

#### Power Source Descriptions

+5V : 5V power source

+3V : 3.3V power source

+12V : 12V power source

CPU\_Core : CPU Core power source.

For Celeron, the voltage is 2.0V

For Pentium III, it is 1.7V

+2.5V : 2.5V power source

+1.8V : 1.8V power source for SIS630 & CPU AGTL + termination  
power source

KBVCCA : KBC AD/DA 3.3V reference voltage

RTCVDL : Real time clock power source

+5V\_AUX : LAN 5V always power source

+3V\_AUX : LAN 3.3V always power source & KBC 3.3V power  
Source

+3V\_RX\_TR : LAN 3.3V analog power source

+3V\_TX\_TR : LAN 3.3V analog power source  
 LCDVCC : LCD display 3.3V power source  
 VIN : Inverter 8~20V power source  
 ADAP+ : 20V Power supply from AC adapter  
 AMPVDD : 5V analog power for audio

**1.2.4 Power Source Status**

	5V	3.3V	12V	CPU _core	VCC_ CMOS	2.5V	1.5V	1.8V
<b>FULL-ON</b>	<b>ON</b>	<b>ON</b>	<b>ON</b>	<b>ON</b>	<b>ON</b>	<b>ON</b>	<b>ON</b>	<b>ON</b>
<b>SLEEP</b>	<b>ON</b>	<b>ON</b>	<b>ON</b>	<b>ON</b>	<b>ON</b>	<b>ON</b>	<b>ON</b>	<b>ON</b>
<b>STD</b>	<b>OFF</b>	<b>OFF</b>	<b>OFF</b>	<b>OFF</b>	<b>OFF</b>	<b>OFF</b>	<b>OFF</b>	<b>OFF</b>
<b>SOFT-OFF</b>	<b>OFF</b>	<b>OFF</b>	<b>OFF</b>	<b>OFF</b>	<b>OFF</b>	<b>OFF</b>	<b>OFF</b>	<b>OFF</b>

**1.2.5 DC/DC Board**

The DC/DC (system power) can support +3.3V, +5V, +12V for the main system.  
 The DC/DC (CPU power) can support +1.3V~2.05V, +1.8V, +2.5V for the CPU.

**1.2.6 AC-DC Adapter**

Input Voltage : 100 ~ 240 ±10% AC  
 Input Frequency : 50 ~ 60 Hz ±3Hz  
 Input AC current : 1.5A max @ 90 VAC  
 Efficiency : Better than 80%  
 Inrush Current : 50A @ 115VAC, 100A @ 230VAC  
 Holdup Time : 5mS (minimum)  
 Output Voltage/Current : 20V / 3.0A  
 Output Load Regulation : ±5%

**1.2.7 Inverter**

Input Voltage : 8-22 VDC  
 Output Voltage : 620 Vrms @ 45~55KHz  
 Start Up Voltage : 1200 Vrms (min.)  
 Brightness Adjust Range (tube current) : 3mA rms – 5.5mA rms  
 Protection : Open circuit protect, current limit protect

**1.2.8 Battery Pack**

**A. Lithium – Ion Battery packs**

- Battery type : Li-Ion
- Battery cells : 8 cells
- Battery Spec : 3.7V / 1800mAH

- Battery power : 47.36 watts (total)
- Battery protection : over charge protect, over discharge protect, over temperature protect, short protect, over current protect

**B. Ni-MH battery packs**

- Battery type : Ni MH
- Battery cells : 10 cells
- Battery specs : 12V, 3800 mAh
- Battery power : 45.6 watts (total)
- Battery protection : over charge protect, over discharge protect, over temperature protect, short protect, over current protect

**1.2.9 Memory Module**

144 pins SO-DIMM, 3.3V, SDRAM

memory type = 1Mx16, 4Mx16, 16Mx16, 2Mx8, 8Mx8, 16Mx8

memory size = 16M, 32M, 64M, 128M,

memory clock = 66 MHz / 100MHz / 133MHz

**Memory Configuration Table**

DIMM 1	DIMM 2	Total
16M	0	16M
32M	0	32M
64M	0	64M
128M	0	128M
16M	16M	32M
16M	32M	48M
32M	32M	64M
16M	64M	80M
32M	64M	96M
64M	64M	128M
64M	128M	192M
128M	128M	256M

**1.2.10 Interrupt Request Channel**

Setting	Hardware using the setting
00	System timer
01	Standard 101/102-Key Microsoft Natural Keyboard
02	Programmable Interrupt Controller
03	IrDA V3.0 Fast Infrared Port
04	Communications Port (Com1)
06	Standard Floppy Disk Controller
07	ECP Printer Port (LPT1)

08	System CMOS/ Real Time Clock (RTC)
09	ACPI IRQ Holder for PCI IRQ Steering
09	SiS 900 PCI Fast Ethernet Adapter
10	ACPI IRQ Holder for PCI IRQ Steering
10	HAMR 5600 Voice Modem
10	O2Micro OZ6812 CardBus Controller
10	SIS 7018 Audio Driver
11	ACPI IRQ Holder for PCI IRQ Steering
11	SIS 7001 PCI to USB Open Host Controller
11	SIS 7001 PCI to USB Open Host Controller
11	SCI IRQ used by ACPI bus
12	Microsoft PS/2 Port Mouse
13	Numeric data processor
14	SIS 5513 Dual PCI IDE Controller
14	Primary IDE Controller (dual FIFO)
15	Intel 82371AB/EB PCI Bus Master IDE Controller
15	Secondary IDE Controller (dual FIFO)

**1.2.11 DMA Channel**

Setting	Hardware using the setting
01	IrDA V3.0 Fast Infrared Port
02	Standard Floppy Disk Controller
03	ECP Printer Port (LPT1)
04	Direct memory access controller

**1.2.12 System LED Indicator**

- 4 Num-lock (on/off)
- 4 Cap-lock (on/off)
- 4 Scroll-Lock (on/off)
- 4 FDD (on/off)
- 4 HDD (on/off)
- 4 CDROM (on/off)
- 4 Power (on/off)

When the system is powered on, the Power LED will be lighted on.  
 When 'Battery Low Warning' occurs, the Power LED will flash at a rate of 1 time every 16 second.

When 'Battery Very Low Warning' occurs, the Power LED will flash at a rate of 1 time every 4 seconds if there is no 'Suspend to Disk' partition in the hard disk.

- 4 Charge (flash/off): Will be flashing when the battery pack is being charged.



**1.2.13 Hot Key:**

<b>Key combination</b>	<b>Function</b>
Fn + F1 (SMI)	Standby Mode
Fn + F4 (SMI)	Toggle LCD / CRT display
Fn + F5 (SMI)	Volume increase
Fn + F6 (SMI)	Volume decrease
Fn + F7 (SMI)	Brightness up
Fn + F8 (SMI)	Brightness down
Fn + F9 (SMI)	Contrast up (for DSTN LCD)
Fn + F10 (SMI)	Contrast down(for DSTN LCD)

# Notebook PC Service Manual

## Model: 340S8

### Chapter 2 Connectors and Switches

**UNIWILL COMPUTER CORP.**  
 No.24, Pei Yuan Rd., Chung Li Industrial Park  
 Chung Li City, Taiwan, R.O.C.  
 TEL: 886-3-461-6000  
 FAX: 886-3-461-6317  
 URL: [http:// www.uniwill.com.tw/](http://www.uniwill.com.tw/)

## 2.1 Connector Definitions

### 2.1.1 Memory DIMM144 Connector (CN5 and CN7)

CN5				CN7			
3	DQ0	DQ32	4	3	DQ0	DQ32	4
5	DQ1	DQ33	6	5	DQ1	DQ33	6
7	DQ2	DQ34	8	7	DQ2	DQ34	8
9	DQ3	DQ35	10	9	DQ3	DQ35	10
13	DQ4	DQ36	14	13	DQ4	DQ36	14
15	DQ5	DQ37	16	15	DQ5	DQ37	16
17	DQ6	DQ38	18	17	DQ6	DQ38	18
19	DQ7	DQ39	20	19	DQ7	DQ39	20
37	DQ8	DQ40	38	37	DQ8	DQ40	38
39	DQ9	DQ41	40	39	DQ9	DQ41	40
41	DQ10	DQ42	42	41	DQ10	DQ42	42
43	DQ11	DQ43	44	43	DQ11	DQ43	44
47	DQ12	DQ44	48	47	DQ12	DQ44	48
49	DQ13	DQ45	50	49	DQ13	DQ45	50
51	DQ14	DQ46	52	51	DQ14	DQ46	52
53	DQ15	DQ47	54	53	DQ15	DQ47	54
83	DQ16	DQ48	84	83	DQ16	DQ48	84
85	DQ17	DQ49	86	85	DQ17	DQ49	86
87	DQ18	DQ50	88	87	DQ18	DQ50	88
89	DQ19	DQ51	90	89	DQ19	DQ51	90
93	DQ20	DQ52	94	93	DQ20	DQ52	94
95	DQ21	DQ53	96	95	DQ21	DQ53	96
97	DQ22	DQ54	98	97	DQ22	DQ54	98
99	DQ23	DQ55	100	99	DQ23	DQ55	100
121	DQ24	DQ56	122	121	DQ24	DQ56	122
123	DQ25	DQ57	124	123	DQ25	DQ57	124
125	DQ26	DQ58	126	125	DQ26	DQ58	126
127	DQ27	DQ59	128	127	DQ27	DQ59	128
131	DQ28	DQ60	132	131	DQ28	DQ60	132
133	DQ29	DQ61	134	133	DQ29	DQ61	134
135	DQ30	DQ62	136	135	DQ30	DQ62	136
137	DQ31	DQ63	138	137	DQ31	DQ63	138
23	DQMB0/CAS0#	A0	29	23	DQMB0/CAS0#	A0	29
25	DQMB1/CAS1#	A1	31	25	DQMB1/CAS1#	A1	31
115	DQMB2/CAS2#	A2	33	115	DQMB2/CAS2#	A2	33
117	DQMB3/CAS3#	A3	30	117	DQMB3/CAS3#	A3	30
24	DQMB4/CAS4#	A4	32	24	DQMB4/CAS4#	A4	32
26	DQMB5/CAS5#	A5	34	26	DQMB5/CAS5#	A5	34
116	DQMB6/CAS6#	A6	103	116	DQMB6/CAS6#	A6	103
118	DQMB7/CAS7#	A7	104	118	DQMB7/CAS7#	A7	104
69	S0#/RAS0#	A8	105	69	S0#/RAS0#	A8	105
71	S1#/RAS1#	A9	109	71	S1#/RAS1#	A9	109
67	WE#	A10	111	67	WE#	A10	111
73	NU/OE#	A11/BA0	106	73	NU/OE#	A11/BA0	110
141	SDA	A12/BA1	110	141	SDA	A12/BA1	112
142	SCL	A13/A11	70	142	SCL	A13/A11	70
11	VCC	RFU/A12	72	11	VCC	RFU/A12	72
12	VCC	RFU/A13	57	12	VCC	RFU/A13	57
27	VCC	NC/CB0	59	27	VCC	NC/CB0	59
28	VCC	NC/CB1	77	28	VCC	NC/CB1	77
45	VCC	NC/CB2	79	45	VCC	NC/CB2	79
46	VCC	NC/CB3	58	46	VCC	NC/CB3	58
63	VCC	NC/CB4	60	63	VCC	NC/CB4	60
64	VCC	NC/CB5	78	64	VCC	NC/CB5	78
81	VCC	NC/CB6	80	81	VCC	NC/CB6	80
82	VCC	NC/CB7	80	82	VCC	NC/CB7	80
101	VCC	VSS	1	101	VCC	VSS	1
102	VCC	VSS	2	102	VCC	VSS	2
113	VCC	VSS	21	113	VCC	VSS	21
114	VCC	VSS	22	114	VCC	VSS	22
129	VCC	VSS	35	129	VCC	VSS	35
130	VCC	VSS	36	130	VCC	VSS	36
143	VCC	VSS	55	143	VCC	VSS	55
144	VCC	VSS	56	144	VCC	VSS	56
61	CLK0	VSS	75	61	CLK0	VSS	75
62	CLK1/RFU	VSS	76	62	CLK1/RFU	VSS	76
68	CKE0/RFU	VSS	91	68	CKE0/RFU	VSS	91
65	SRAS#/RFU	VSS	92	65	SRAS#/RFU	VSS	92
66	SCAS#/RFU	VSS	107	66	SCAS#/RFU	VSS	107
		VSS	108			VSS	108
		VSS	119			VSS	119
		VSS	120			VSS	120
		VSS	139			VSS	139
		VSS	140			VSS	140

DIMM144

DIMM144-REV

### 2.1.2 MDC (Software Modem) Connector (CN27)

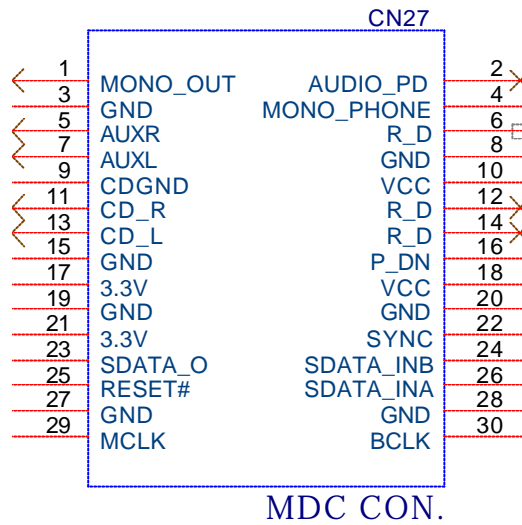

### 2.1.3 SIS 630S Clock DIP Switch (SW3)

Frequency Selection

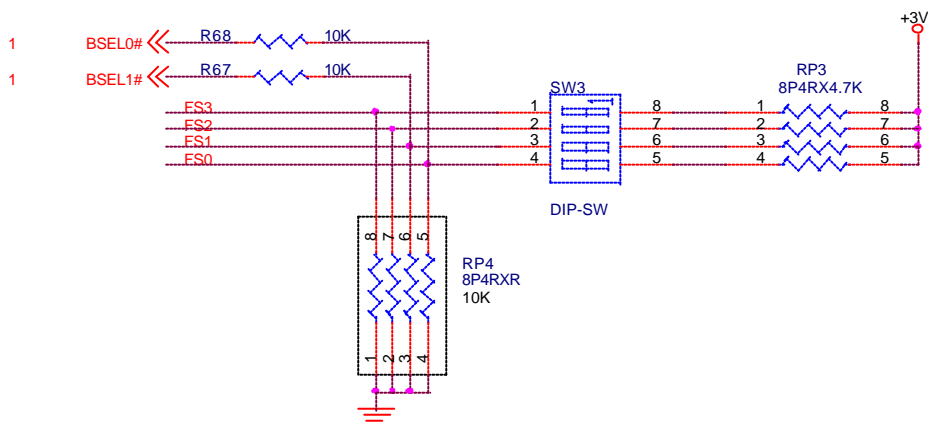

#### SiS 630S CLOCK Select

SW3				CPU	SDRAM	PCI	REF
1	2	3	4				
OFF	OFF	OFF	OFF	66.6	66.6	33.3	14.318
OFF	OFF	OFF	ON	100	100	33.3	14.318
OFF	OFF	ON	ON	133	133	33.3	14.318
OFF	ON	OFF	OFF	66.6	100	33.3	14.318
OFF	ON	OFF	ON	100	66.6	33.3	14.318
OFF	ON	ON	OFF	100	133	33.3	14.318
OFF	ON	ON	ON	133	100	33.3	14.318
ON	ON	OFF	OFF	66.6	133	33.3	14.318

W83194BR-63S  
ICS9248-146 (ICS)

### 2.1.4 Inverter Connector (CN2) & MIC Connector (CN35)

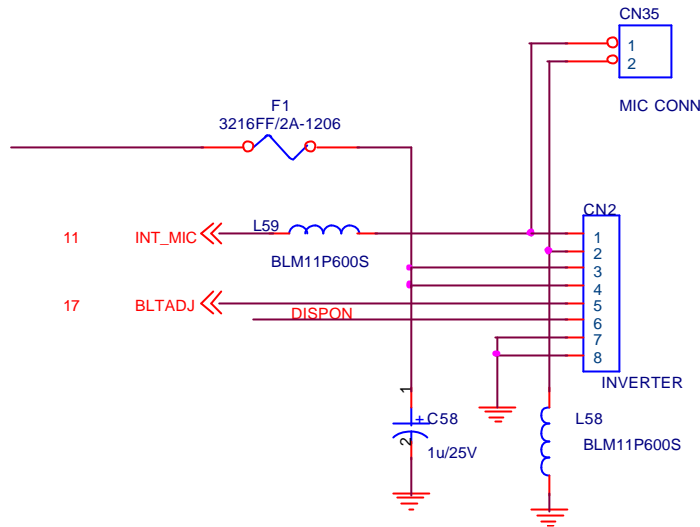

### 2.1.5 USB Connector (CN20)

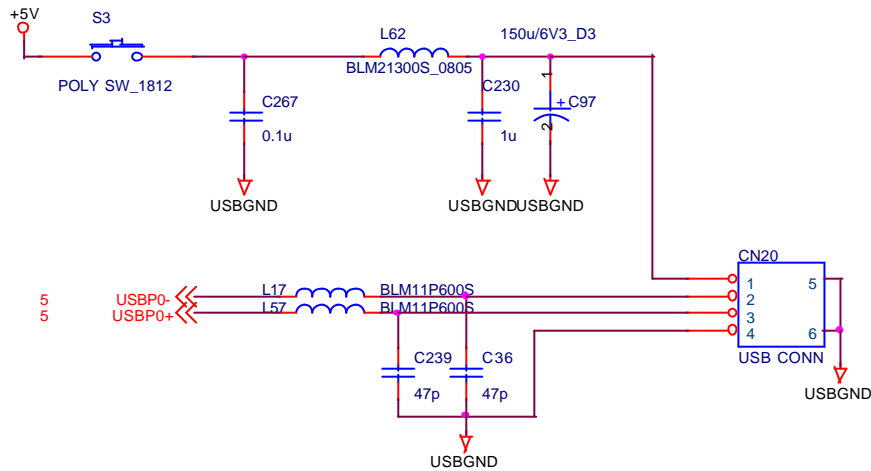

### 2.1.6 CRT Connector (CN15)

Pin	Description	Pin	Description
1	RED	9	+5V
2	GREEN	10	GND
3	BLUE	11	NC-
4	NC	12	DDCCLK
5	GND	13	HSYNC
6	DACGND	14	VSYNC
7	DACGND	15	DDCDATA
8	DACGND		

### 2.1.7 Modem Phone (CN19) and Modem Connector (CN22)

# MODEM

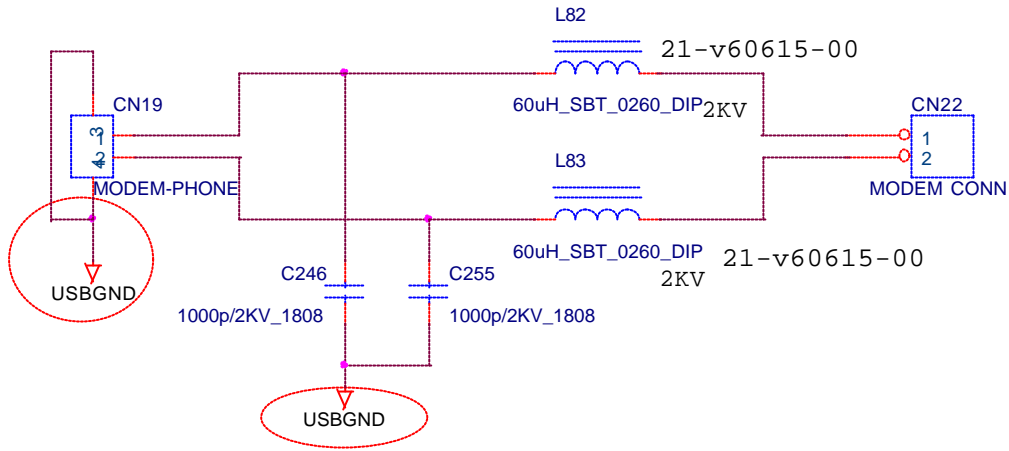

## 2.1.8 LAN - RJ45 Connector (CN16)

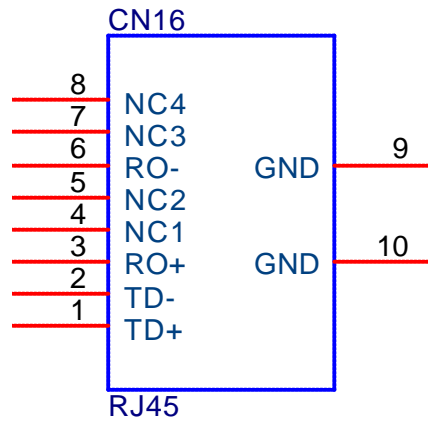

## 2.1.9 Speaker Jack (CN12)

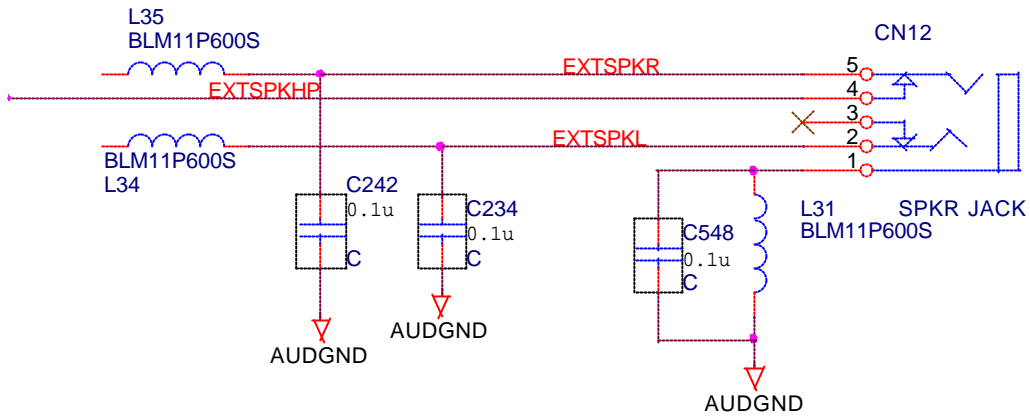

### 2.1.10 R/L Speaker Connector (CN3)

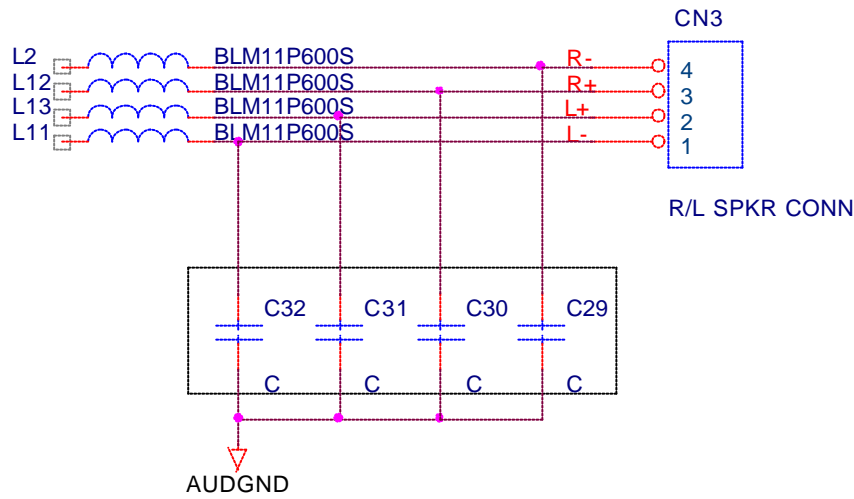

### 2.1.11 Microphone Jack (CN13)

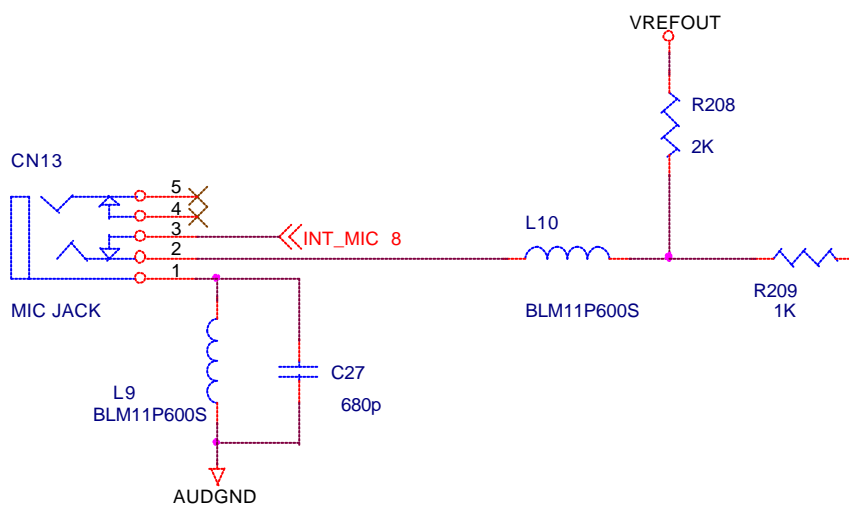

### 2.1.12 PCMCIA Connector (CN28)

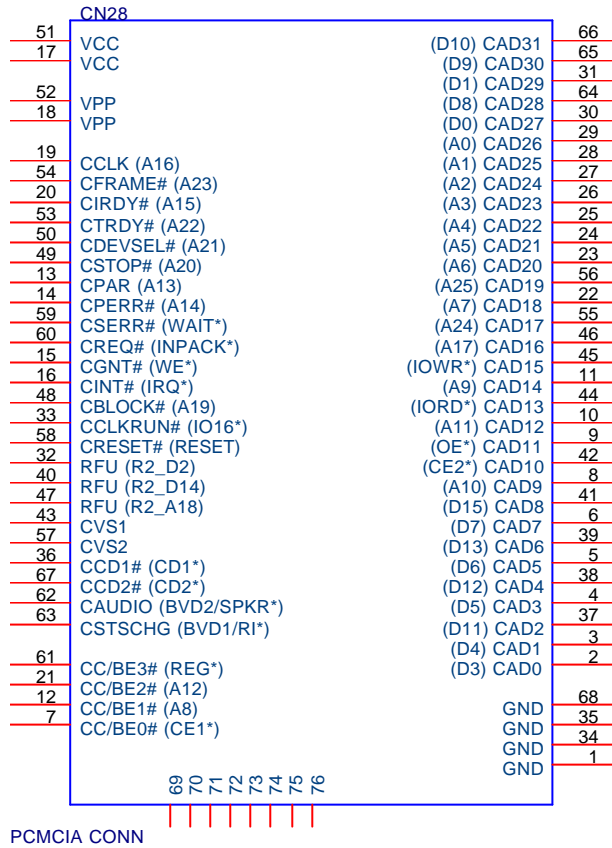

### 2.1.13 HDD Connector (CN26)

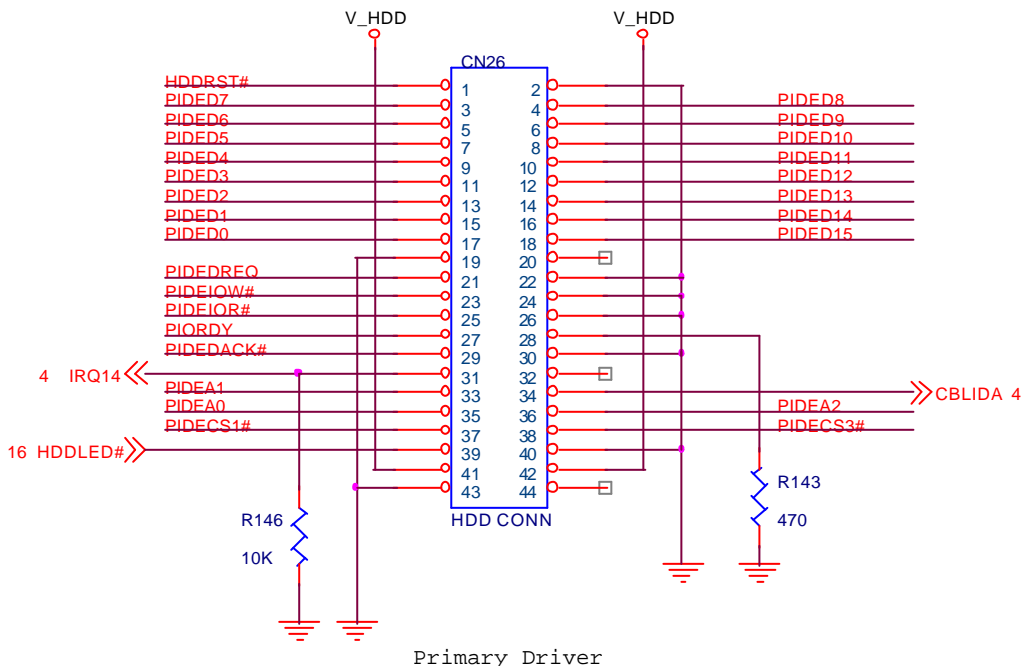

### 2.1.14 CDROM Connector (CN23)

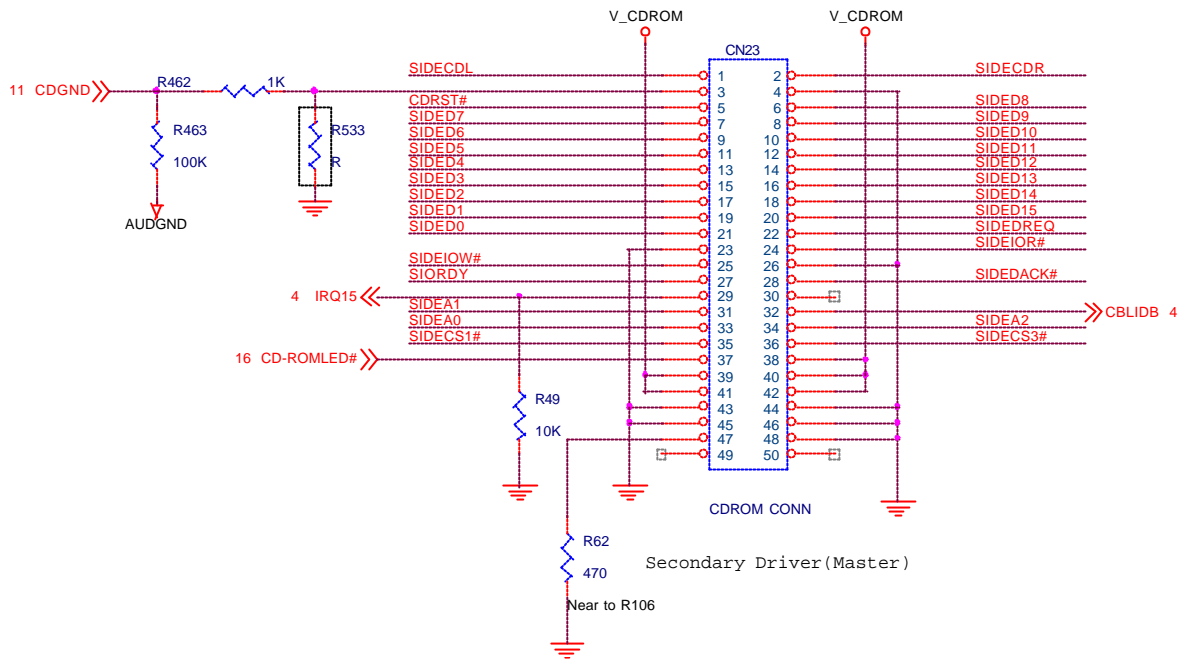

### 2.1.15 FDD Connector (CN10)

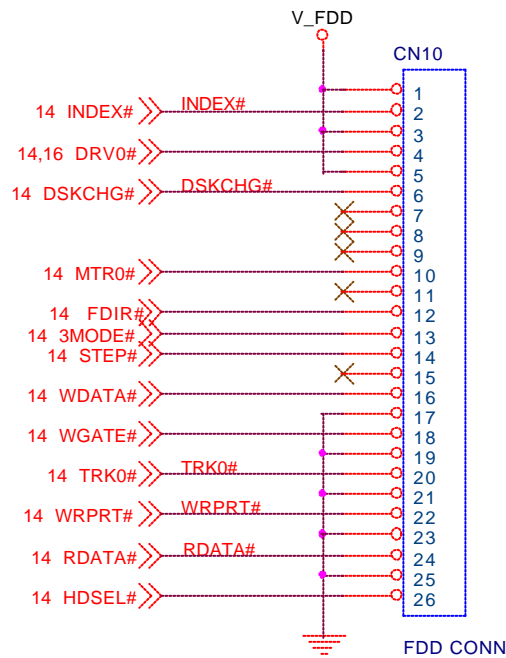

### 2.1.16 Parallel Connector (CN17)



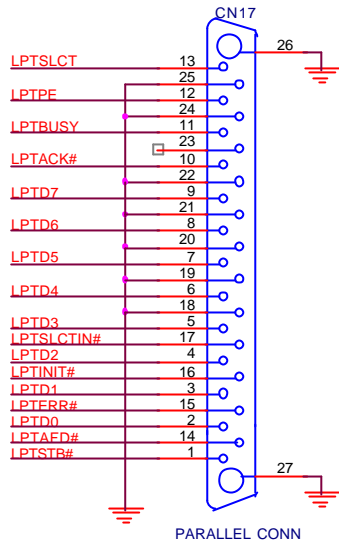

### 2.1.17 Serial Connector (CN18)

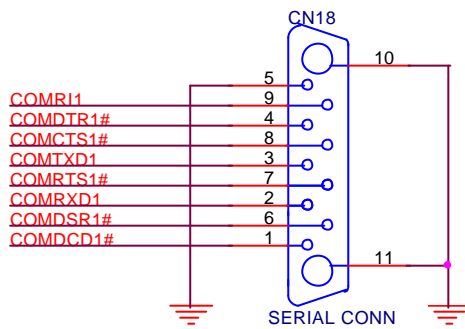

### 2.1.18 PS/2 Connector (CN14)

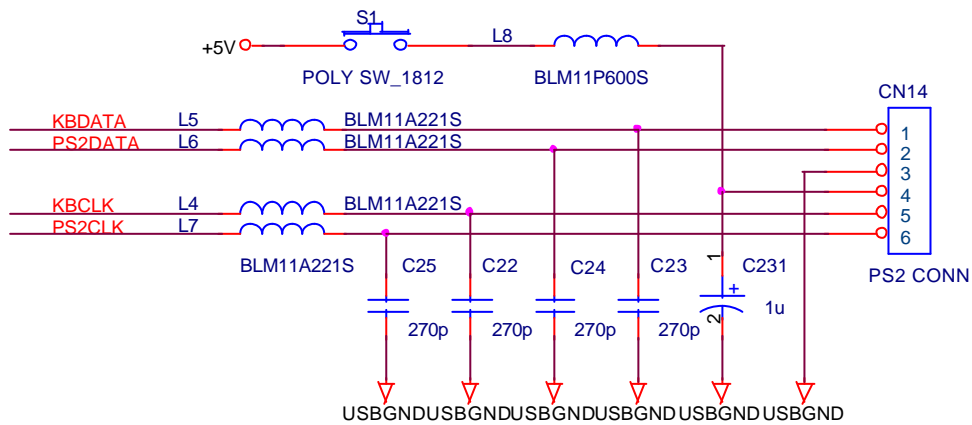

### 2.1.19 PS/2 Connector (CN14)

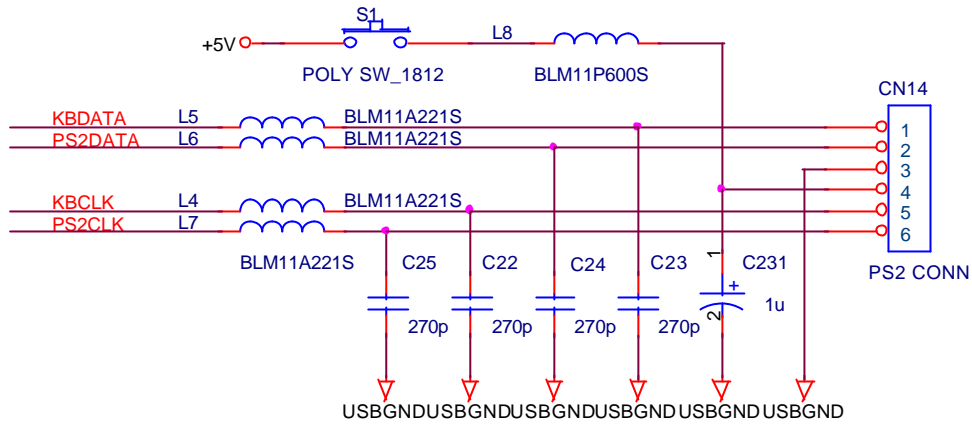

### 2.1.20 Internal KB Connector (CN8)

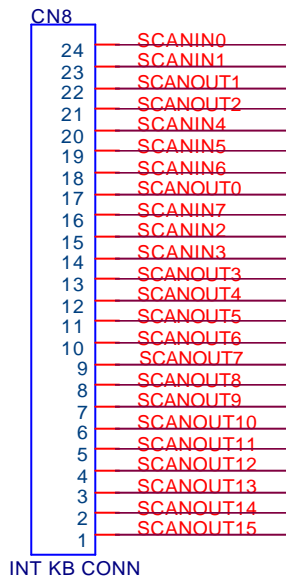

### 2.1.21 Touch Pad Connector (CN11)

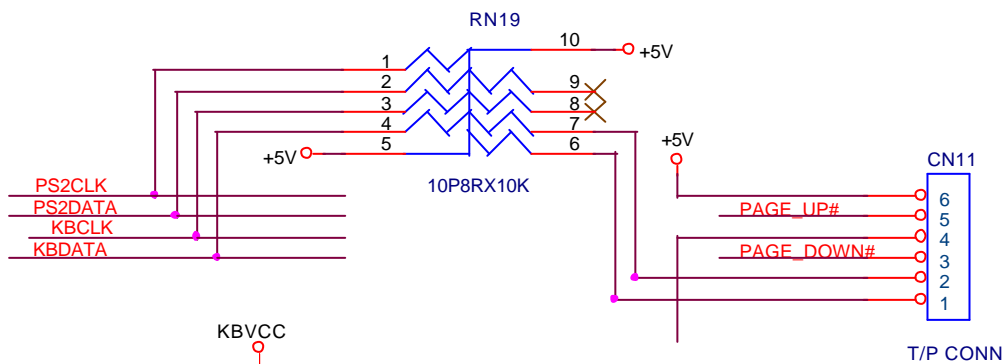

### 2.1.22 Fan 1 (CN24) and Fan2 (CN25) Connector

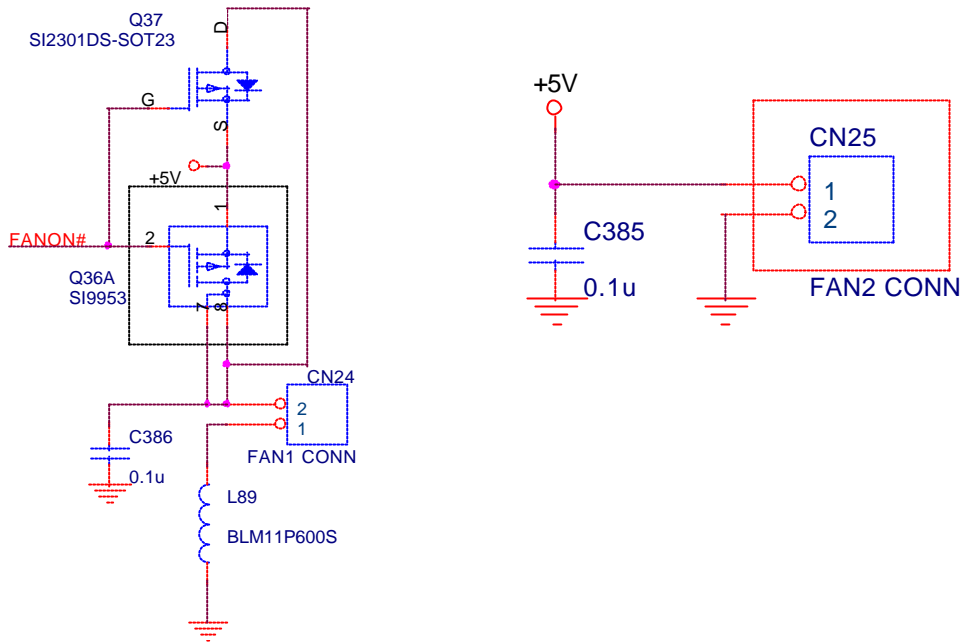

## 2.2 Mechanical Buttons and Switch Definition

### 2.2.1 Power on/off button

1. If the system is in S0, S1 or S2 state, pressing the power button will transit the system to S4 (Suspend to Disk) or S5 (Soft-off) state depending on the “Power button function” setting in the BIOS Setup menu.
2. If the system is in S4 or S5 states, pressing the power button will awaken the system into S0 states.
3. If the power button is pressed for more than four seconds, a power button over-ride event is generated and the system will be put into S5 (Soft-off) state.

### 2.2.2 Cover (Lid) Switch

When LCD cover is closed, this Lid switch is triggered and an SMI/SCI is generated to put the system into ‘Suspend to RAM’ or ‘Suspend to Disk’ mode depending on the “Cover Switch” setting in the BIOS Setup menu.

### 2.2.3 Quick Start Button

When this button has been pressed, the system will launch either Microsoft Internet Explorer, E-Support or E-mail/User Defines etc. 3 quick buttons demands.

## 2.3. Major Components and Connectors Location

### 2.3.1 Top Side

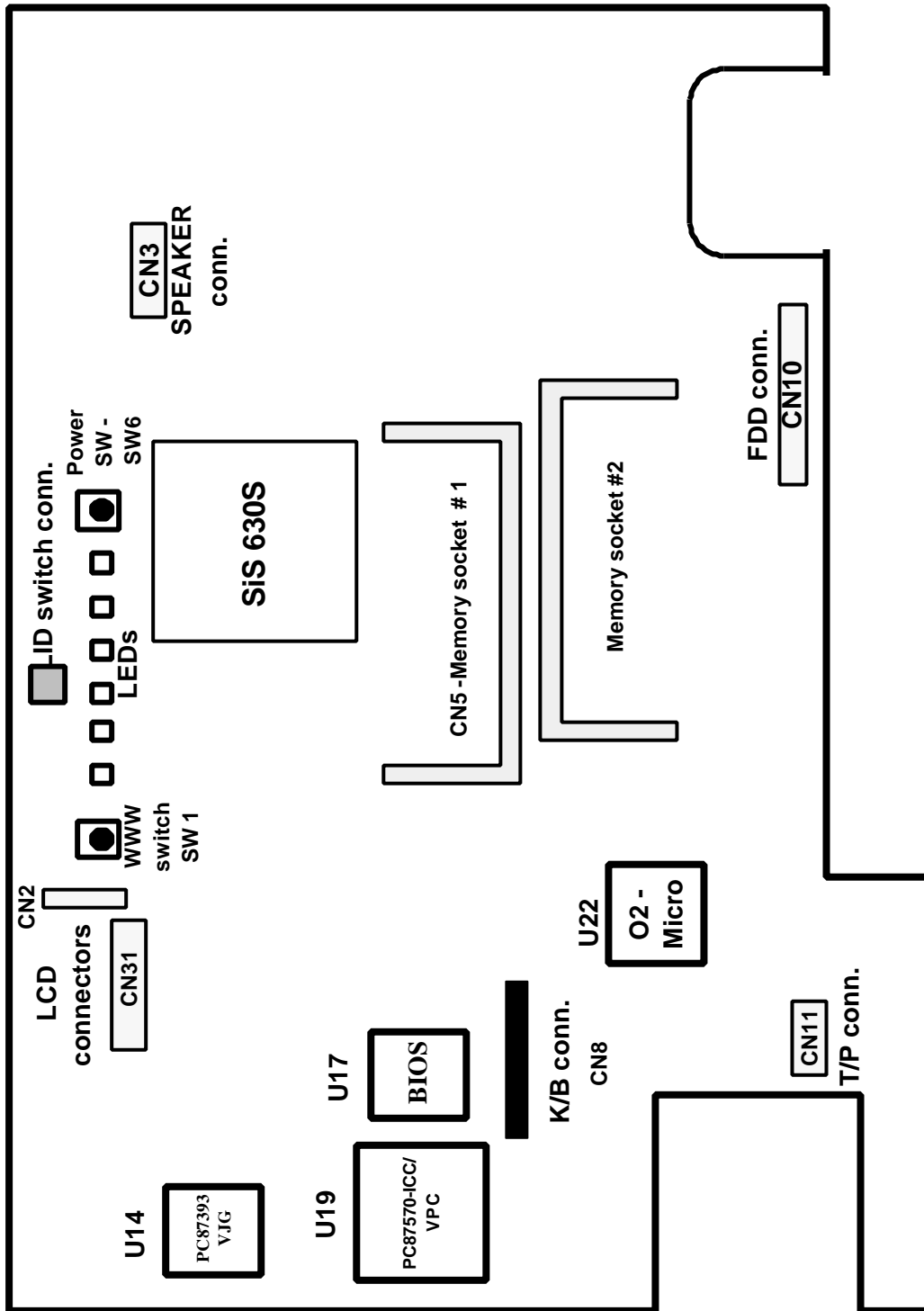

### 2.3.2 Top Side

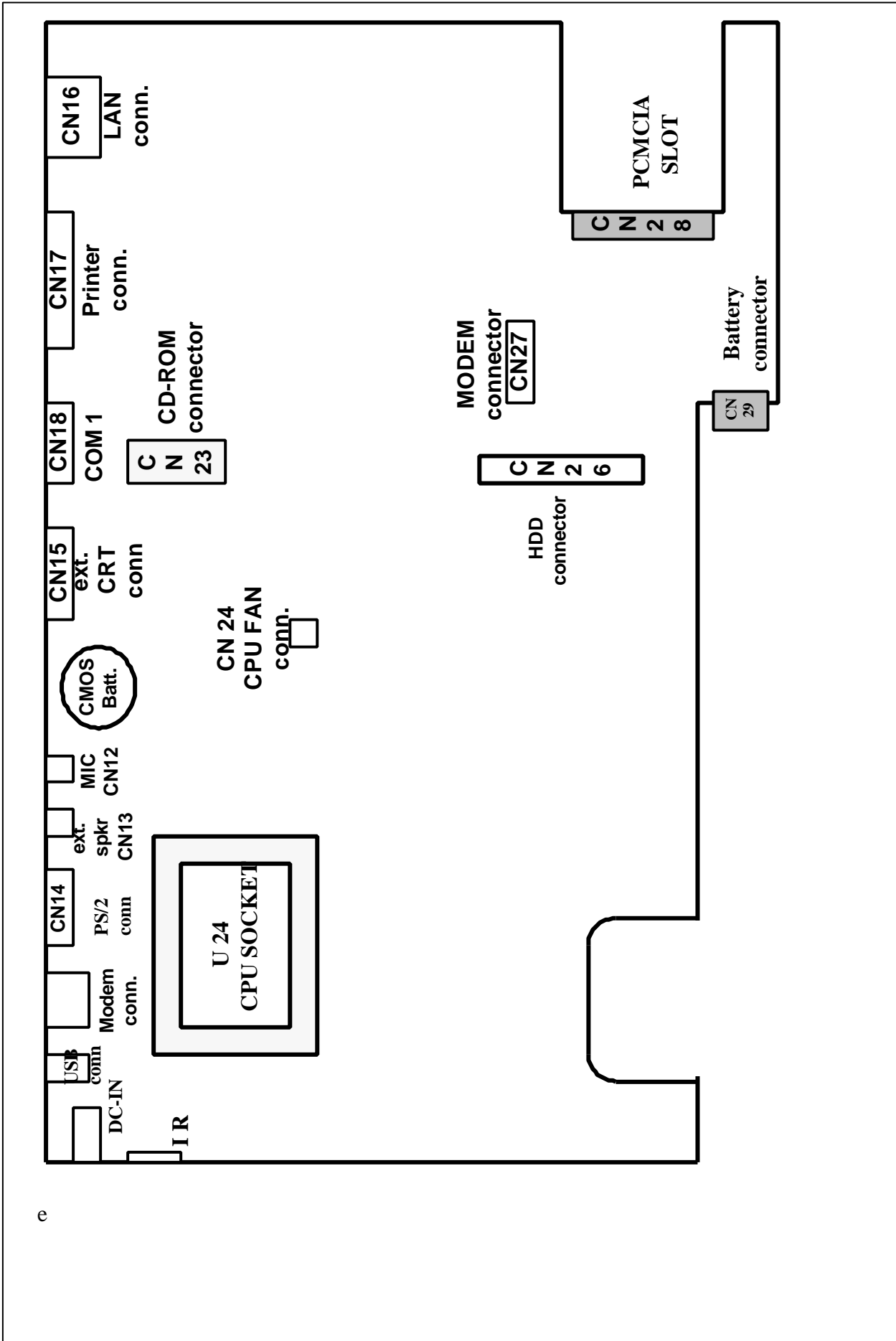

**Model : 346S8**

**Chapter 3**  
**Major Components**

**UNIWILL COMPUTER CORP.**

No. 24, Pei Yuan Rd., Chung Li Industrial Park  
Chung Li City, Taiwan, R.O.C.

TEL: 886-3-461-6000

FAX: 886-3-461-6317

URL: <http://www.uniwill.com.tw/>

### 3.1 Major Component List

Reference	Component	Part Number
U1	IC ALC-200 LQFP	02-U10002-30
U2	IC RTL8201 LQFP48P PHY	02-F82010-40
U3	IC GD75232 SOP20P RS-232	03-E75232-60
U4	IC LM4835 TSSOP-28	08-U00057-0U
U6	IC ADM1021 16 PIN QSOP	08-U10025-00
U8	IC DS90C363A TSSOP48P LVDS	03-F90363-95
U10	SIS 630S BGA 762 PIN MULTI-FUNCTION	02-A63001-A0
U11	IC SN74LVC14 14 PIN (T1)	07-U32037-00
U12	IC 74LVC08 QUAD 2 – INPUT	07-U32038-00
U13	IC 74LVC 32 0.65mm TSSOP -14P	07-U32057-00
U14	IC PC87393 TQFP 100 LPC-SUPERI/O	02-U50004-00
U18	IC ICS9248 –146 SSOP48P CLK GEN	03-A92481-70
U19	IC PC 87570 K/B AND POWER MANAGEMENT	02-U60001-00
U20	IC TC7SH32FU SINGLE 2 -INPUT	07-U81024-00
U21	IC MIC256A SO-14 9MICREL)	08-U10032-00
U22		
U23	IC LM358M SOP 8P (NS)	08-U00017-0U
U25	IC 74LVC 244 TSSOP-20	07-U32097-00
U26	IC AME8800 DEFT SOT-89 2.5V 30	08-U10067-00
U27	IC LTC 1736CG 24PIN SSOP	08-U20007-00
U28	IC PACS1284-020 /T QSOP28	08-U90009-00
U29	IC 74HCT 4066D PHILIPS	07-U21031-00
U30	IC BA9743AFV 16P	08-U90013-00
U32	IC LM78L12AC SOIL 8P	08-U10008-00
U33	IC MB3878 24 PIN	08-C38780-40
U34	IC TL594CD PWM CONTROL SO-16	08-159400-40
U35	IC PACS1284-020 /T QSOP28	08-U90009-00

### 3.2 Major Components Pin Assignment

### SOCKET\_370 (U24A)

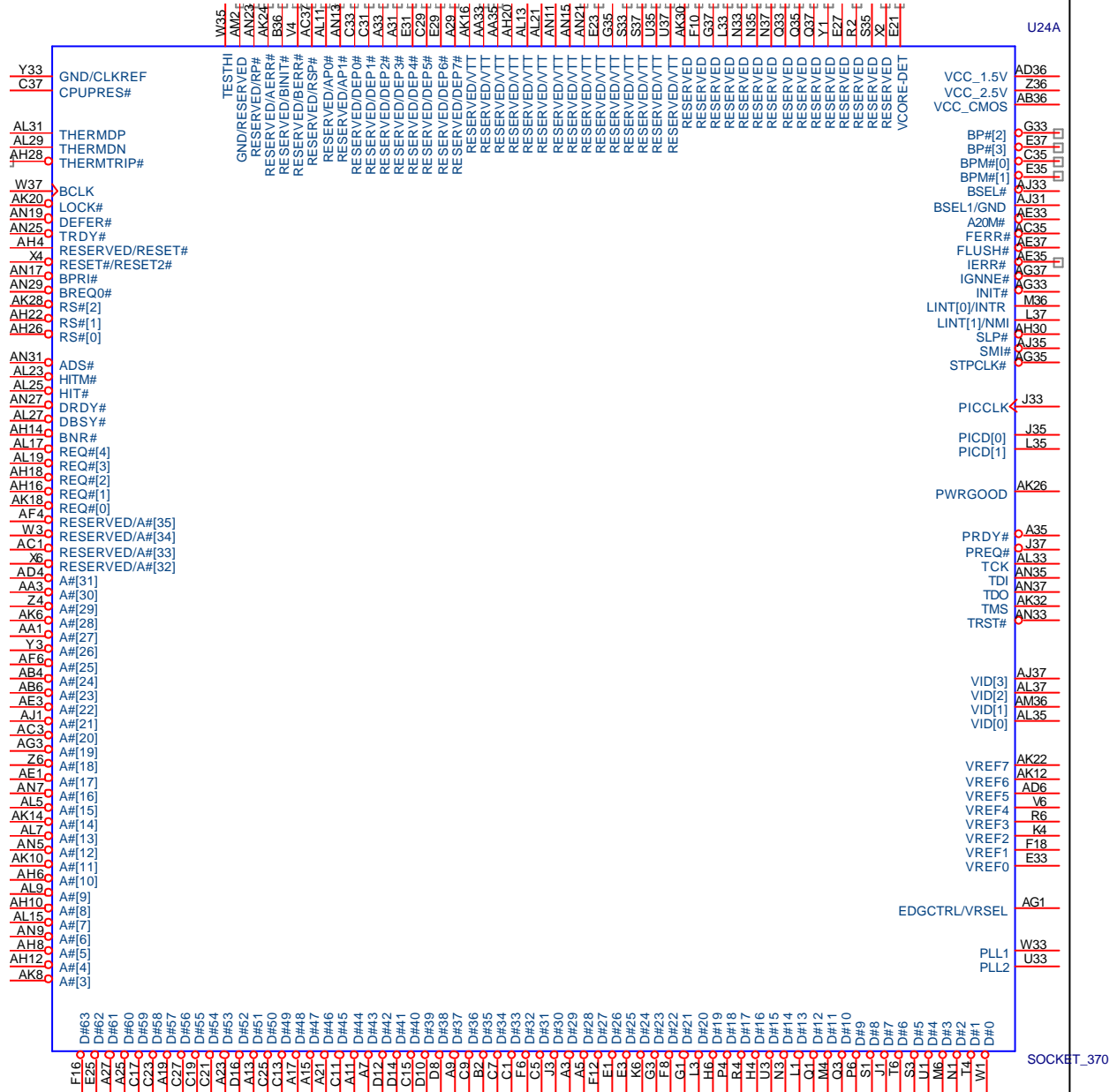

### SOCKET\_370 (U24B)



U24B

AA37	VCC_CORE	GND	A37
AA5	VCC_CORE	GND	AB32
AB2	VCC_CORE	GND	AC33
AB34	VCC_CORE	GND	AC5
AD32	VCC_CORE	GND	AD2
AE5	VCC_CORE	GND	AD34
AF2	VCC_CORE	GND	AF32
AF34	VCC_CORE	GND	AF36
AH24	VCC_CORE	GND	AG5
AH32	VCC_CORE	GND	AH2
AH36	VCC_CORE	GND	AH34
AJ13	VCC_CORE	GND	AJ11
AJ17	VCC_CORE	GND	AJ15
AJ21	VCC_CORE	GND	AJ19
AJ25	VCC_CORE	GND	AJ23
AJ29	VCC_CORE	GND	AJ27
AJ5	VCC_CORE	GND	AJ3
AJ9	VCC_CORE	GND	AJ7
AK2	VCC_CORE	GND	AK36
AK34	VCC_CORE	GND	AK4
AM12	VCC_CORE	GND	AL1
AM16	VCC_CORE	GND	AL3
AM20	VCC_CORE	GND	AM10
AM24	VCC_CORE	GND	AM14
AM28	VCC_CORE	GND	AM18
AM32	VCC_CORE	GND	
AM4	VCC_CORE	GND	AM22
AM8	VCC_CORE	GND	AM26
B10	VCC_CORE	GND	AM30
B14	VCC_CORE	GND	AM34
B18	VCC_CORE	GND	AM6
B22	VCC_CORE	GND	AN3
B26	VCC_CORE	GND	B12
B30	VCC_CORE	GND	B16
B34	VCC_CORE	GND	B20
B6	VCC_CORE	GND	B24
C3	VCC_CORE	GND	B28
D20	VCC_CORE	GND	B32
D24	VCC_CORE	GND	B4
D28	VCC_CORE	GND	B8
D32	VCC_CORE	GND	D18
D36	VCC_CORE	GND	D2
D6	VCC_CORE	GND	D22
E13	VCC_CORE	GND	D26
E17	VCC_CORE	GND	D30
E5	VCC_CORE	GND	D34
E9	VCC_CORE	GND	D4
F14	VCC_CORE	GND	E11
F2	VCC_CORE	GND	E15
F22	VCC_CORE	GND	E19
F26	VCC_CORE	GND	E7
F30	VCC_CORE	GND	F20
F34	VCC_CORE	GND	F24
F4	VCC_CORE	GND	F28
H32	VCC_CORE	GND	F32
H36	VCC_CORE	GND	F36
J5	VCC_CORE	GND	G5
K2	VCC_CORE	GND	H2
K32	VCC_CORE	GND	H34
K34	VCC_CORE	GND	K36
M32	VCC_CORE	GND	L5
N5	VCC_CORE	GND	M2
P2	VCC_CORE	GND	M34
P34	VCC_CORE	GND	P32
R32	VCC_CORE	GND	P36
R36	VCC_CORE	GND	Q5
S5	VCC_CORE	GND	R34
T2	VCC_CORE	GND	T32
T34	VCC_CORE	GND	T36
V32	VCC_CORE	GND	U5
V36	VCC_CORE	GND	V2
W5	VCC_CORE	GND	V34
X34	VCC_CORE	GND	X32
Y35	VCC_CORE	GND	X36
Z32	VCC_CORE	GND	Y37
		GND	Y5
		GND	Z2
		GND	Z34
		GND	

SOCKET\_370

### Temperature Sensor (U5)

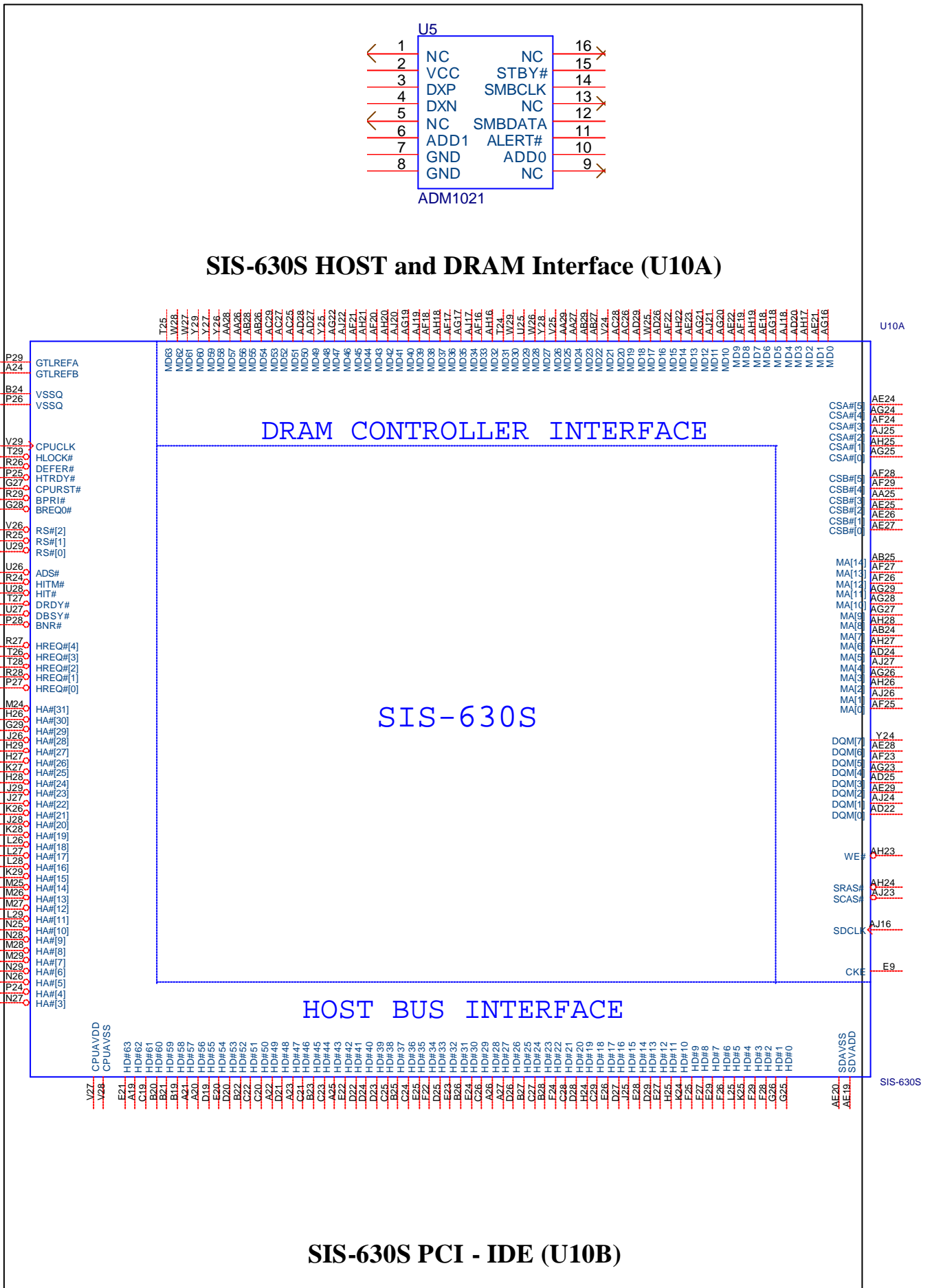

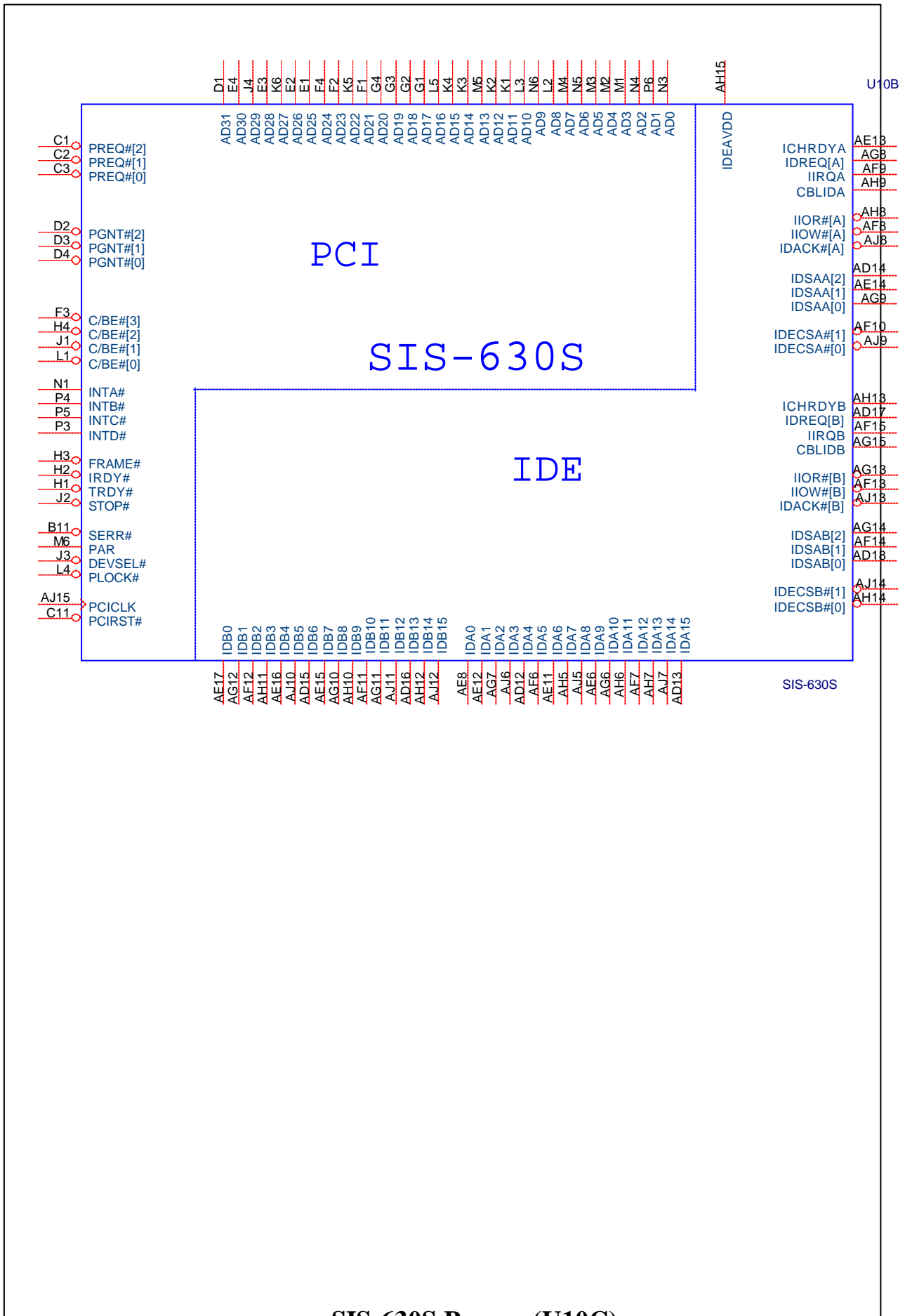

SIS-630S Power (U10C)

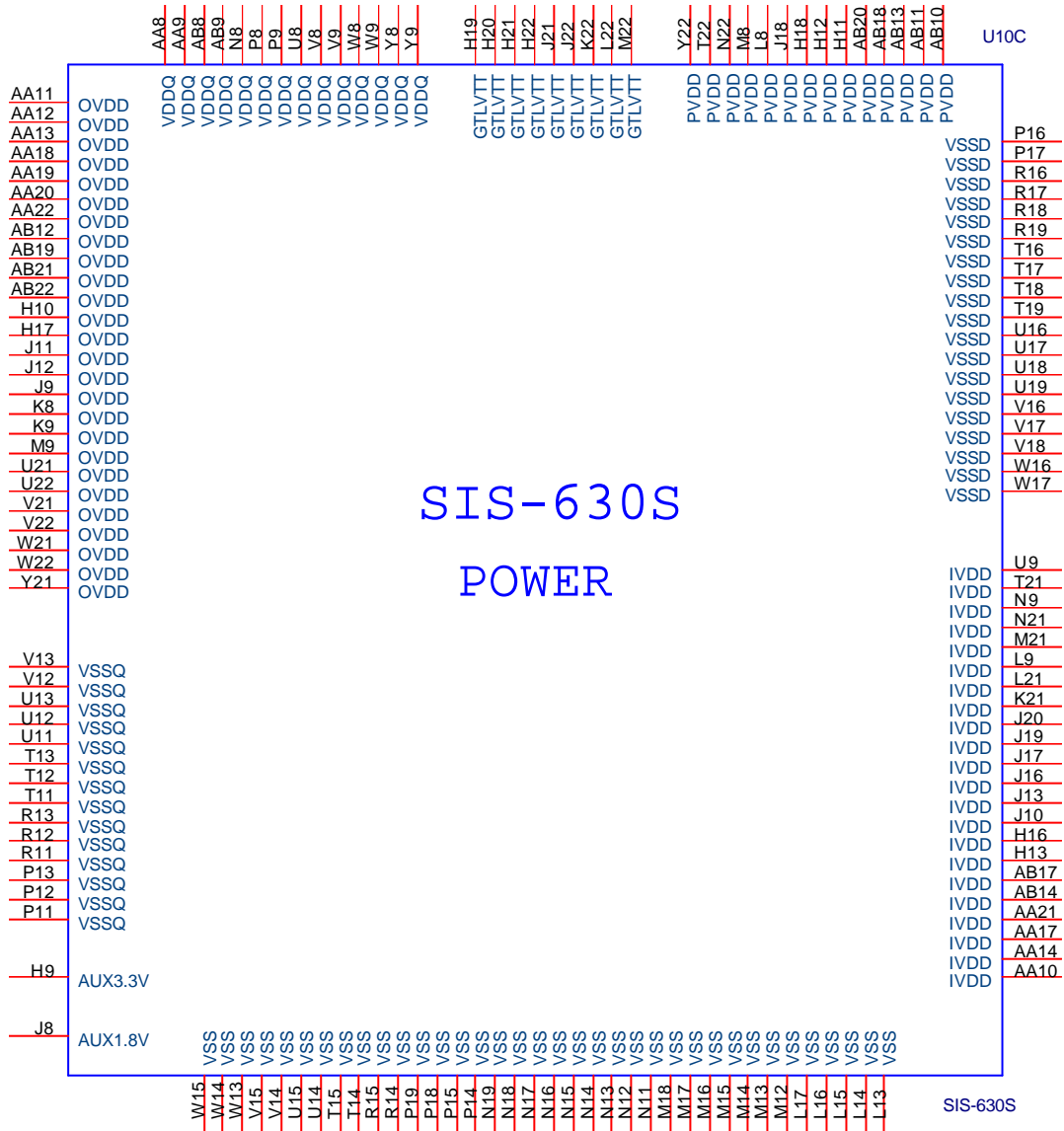

**SIS 630S – VGA & South Bridge (U10D)**

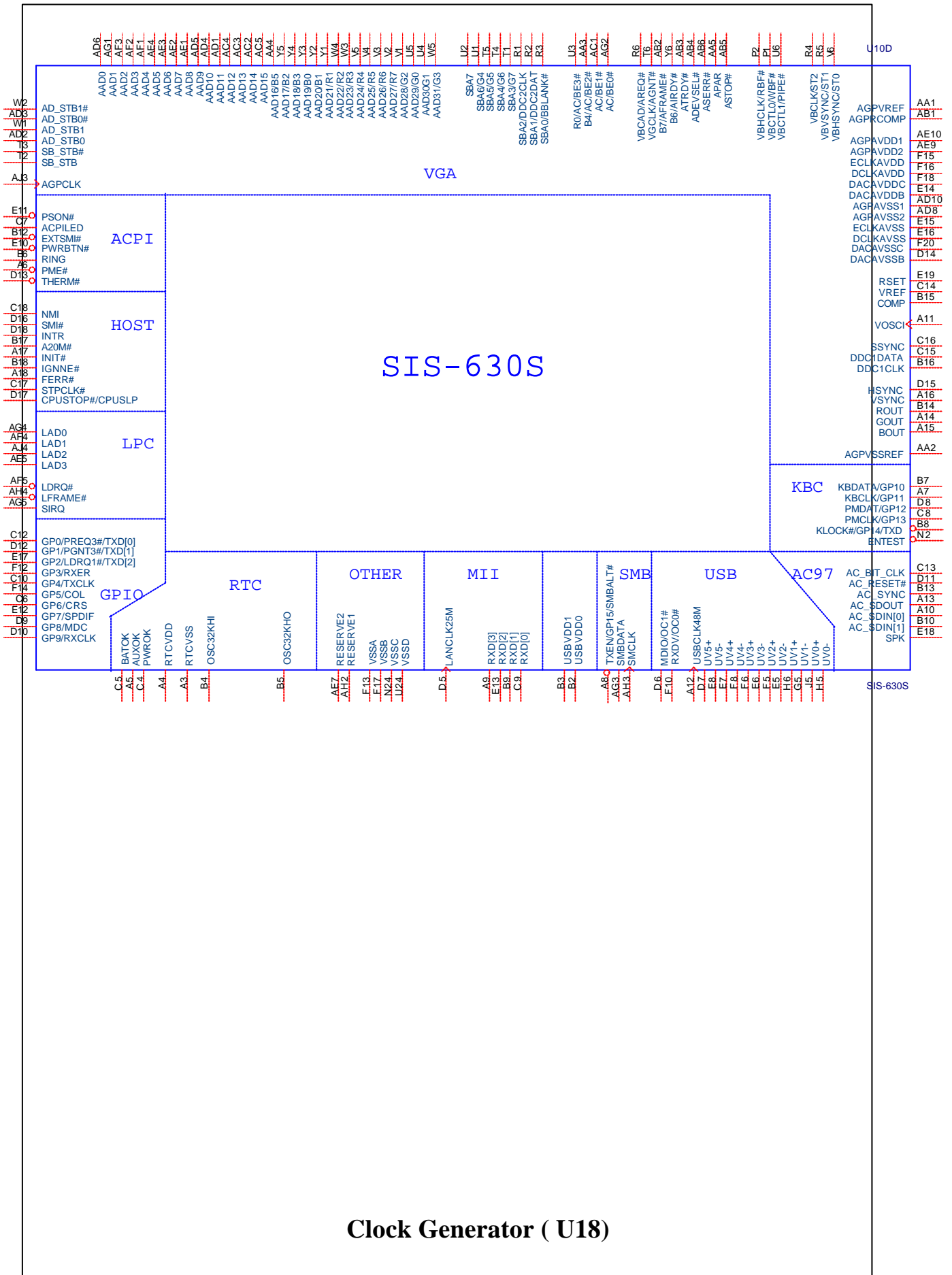

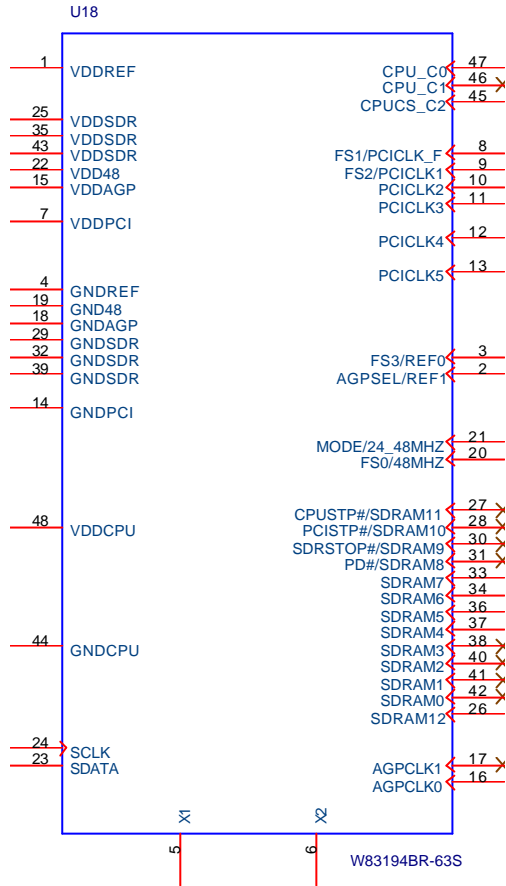

RAM Switch (U29)

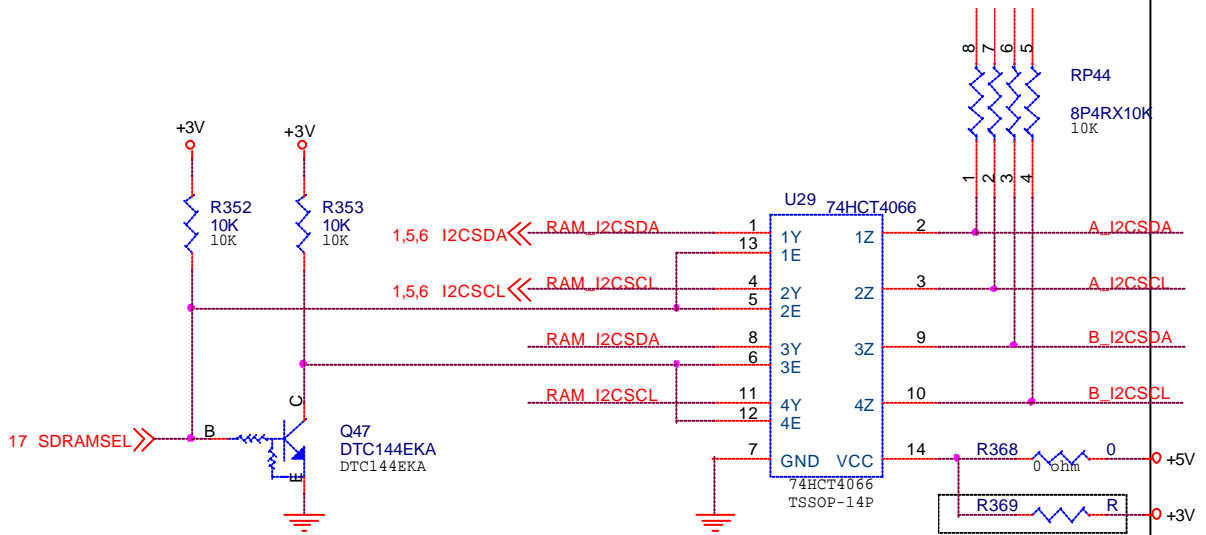

RTL 8201 (U2)

Octal Buffer (U25)



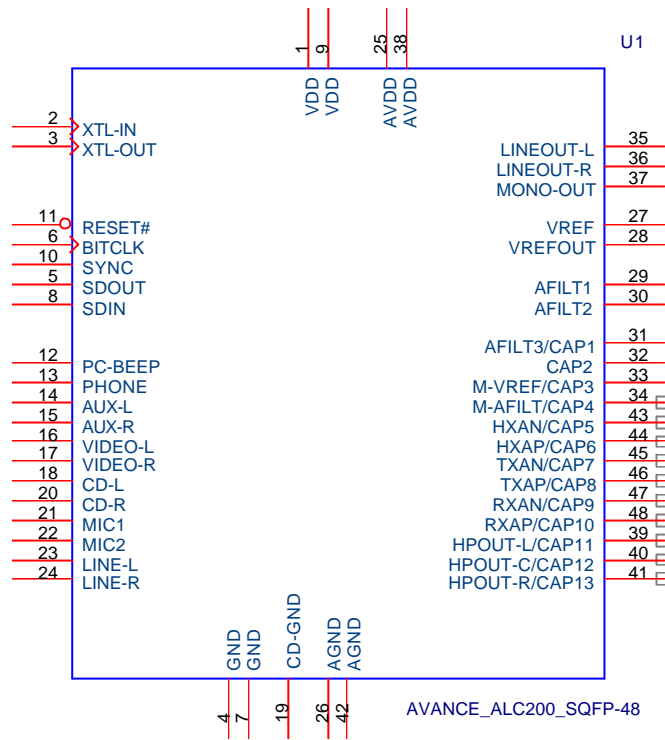

### Audio Amplifier (U4)

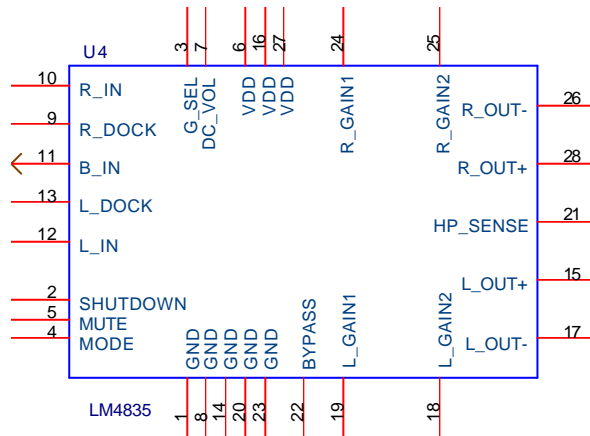

### PCMCIA Controller (U22)



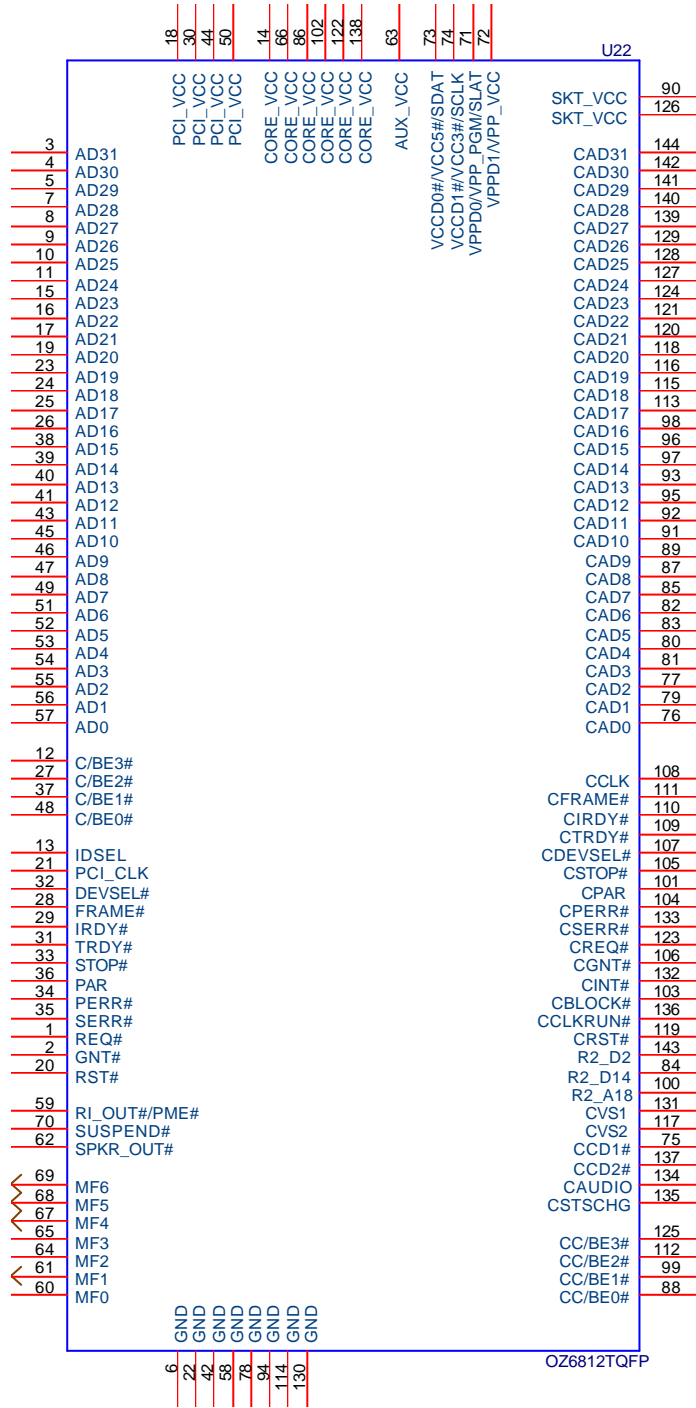

PCMCIA Power Controller (U21)

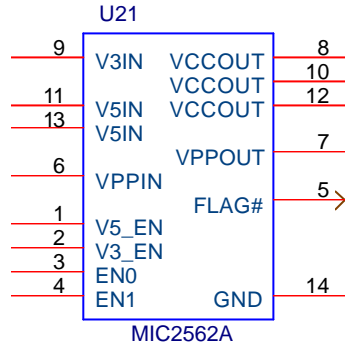

**Super I/O Controller (U14)**

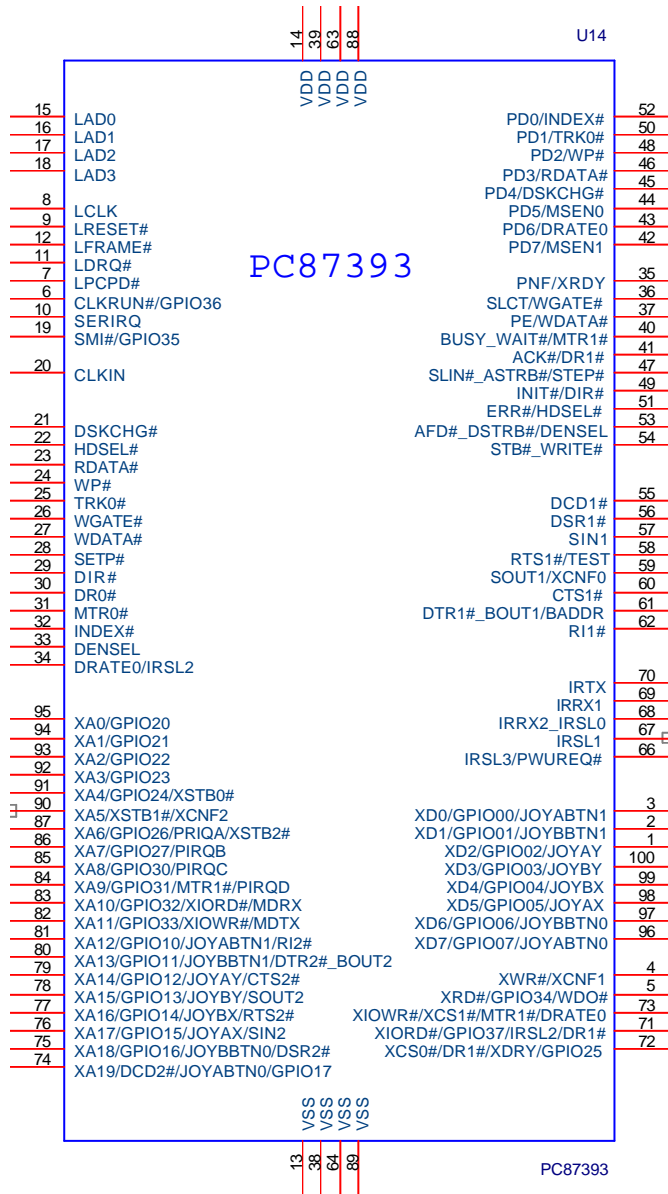

**Switch (U16)**

**QSOP-28 (U35)**

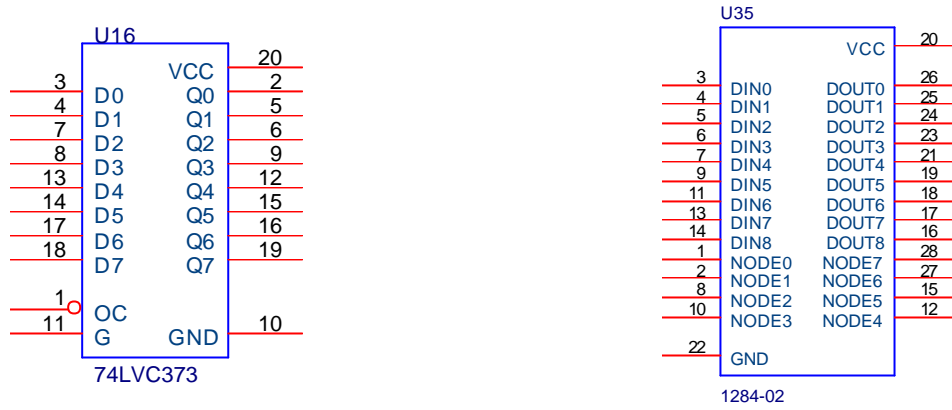

### Keyboard Controller (PC87570)

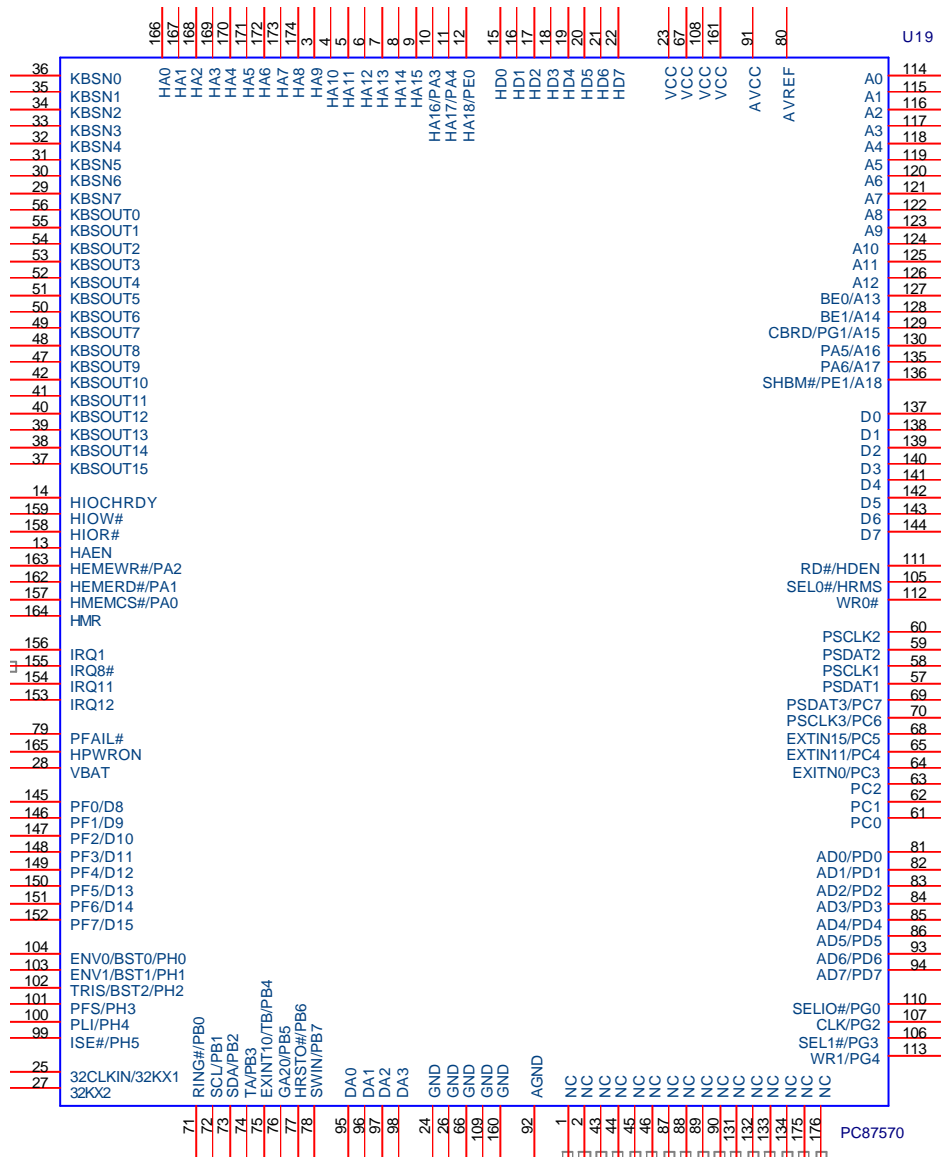

RS-232 Transceiver (U3)

BIOS EEPROM Socket (U17)

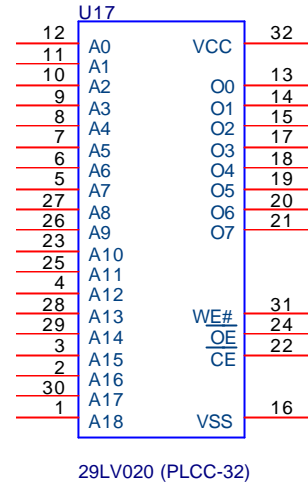
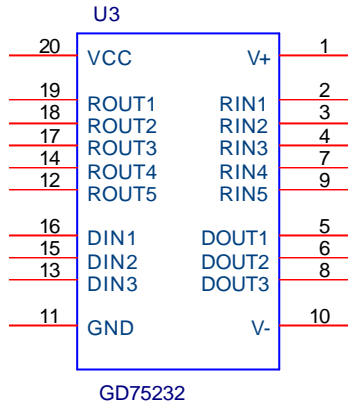

**PWM Control (U28)**

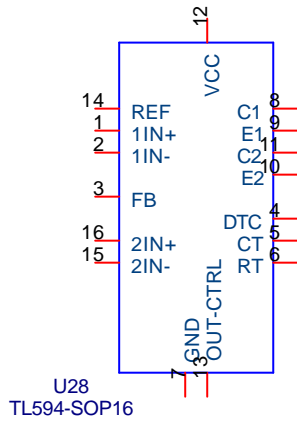

**PWM Control (U34)**

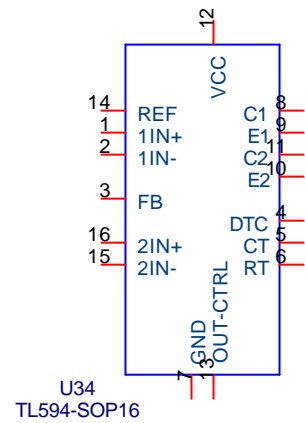

**Low Dropout Regulator (U26)**

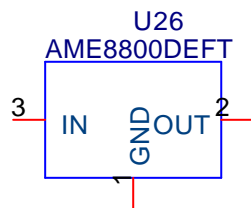

**Linear Regulator (U32)**

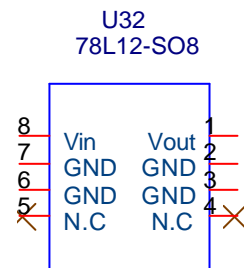

**DC-DC Converter (U30)**

**Charger (U33)**

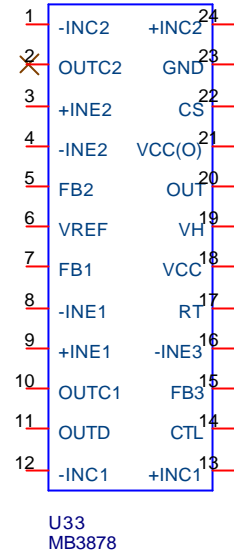
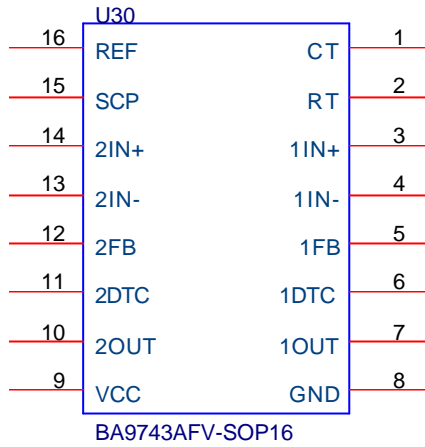

### LTC 1736 (U27)

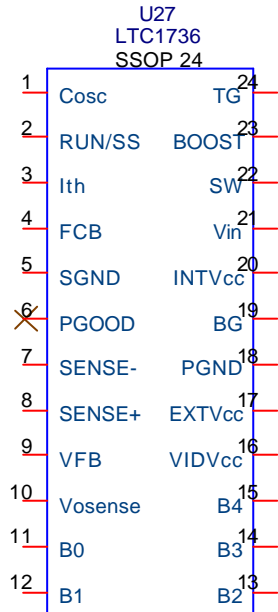

Notebook PC Service Manual

**Model : 340S8**

**Chapter 4**  
**System Disassembly**

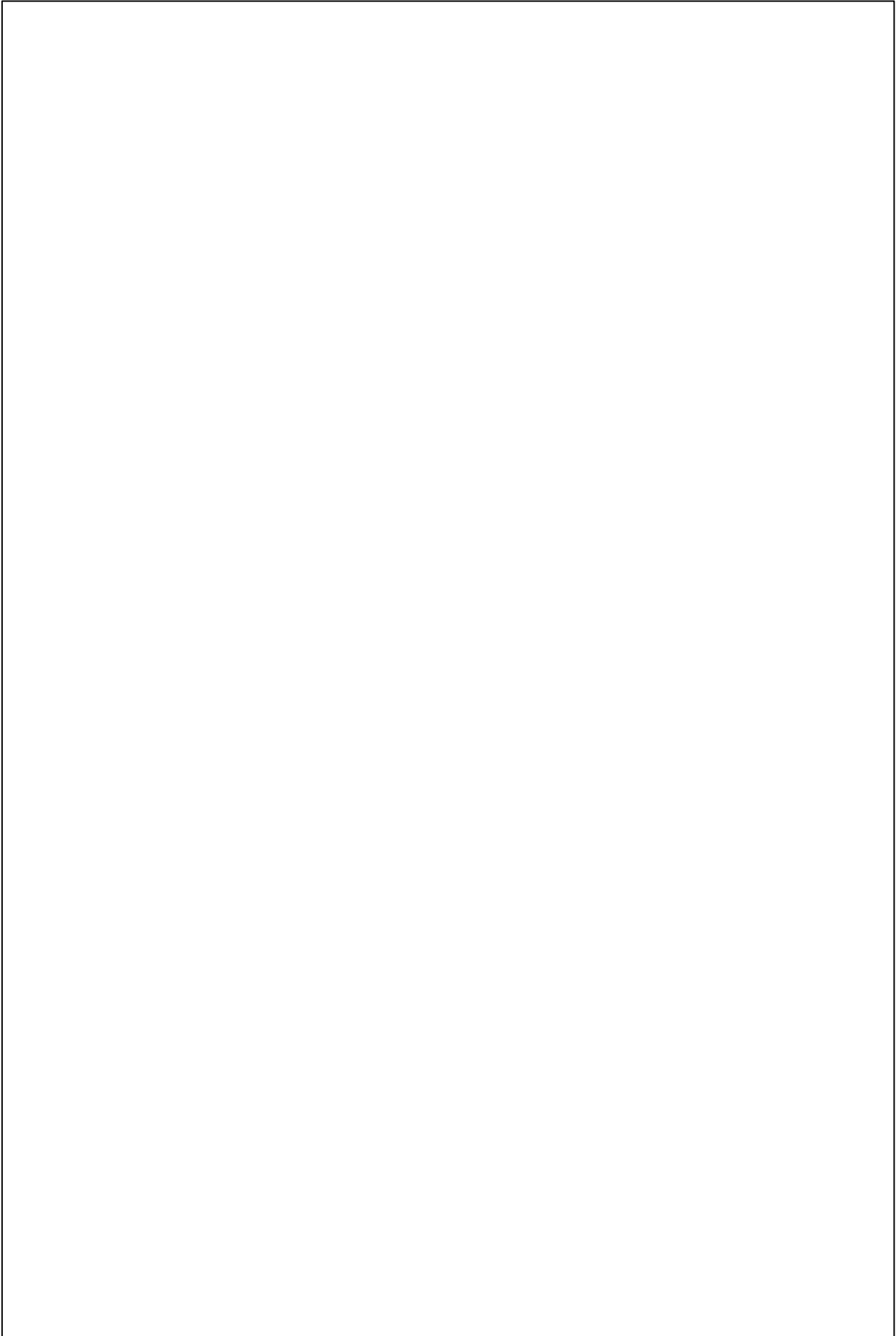

**System Disassembly Procedure**

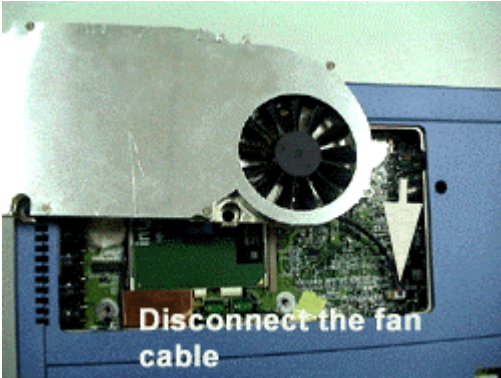
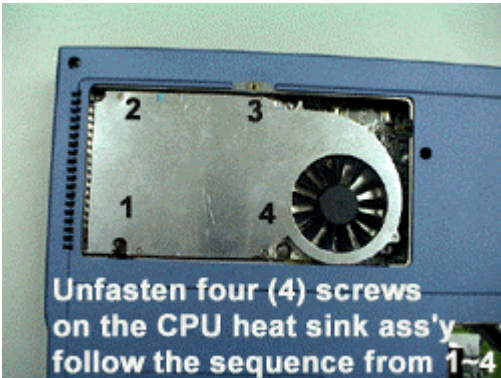
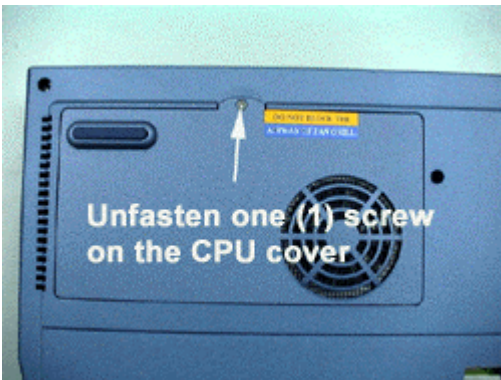



1. Before doing the disassembly, you **MUST** first remove the battery from the battery compartment and no external power is supplied to the machine.
  
2. Unfasten the one (1) screw on the CPU cover.
  
3. Unfasten four (4) screws on the CPU fan + heat sink assembly. Please follow the sequence when unfastening.

When fastening, you must start on # 4 , 3 , 2 and 1 ( counter clockwise direction)

4. Disconnect the cable CPU fan + heat sink assembly from the mainboard.

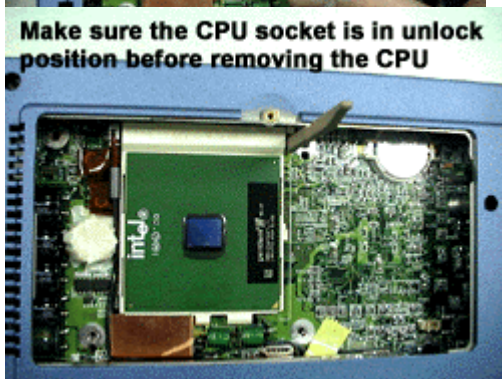
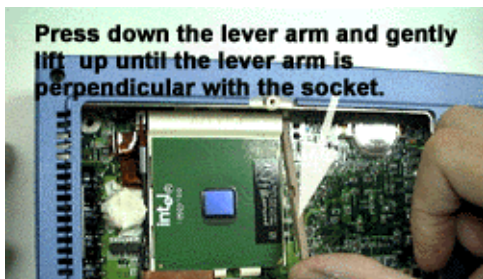

5. Gently press down the lever arm of the CPU socket and lift it up until the lever arm is in stand position.

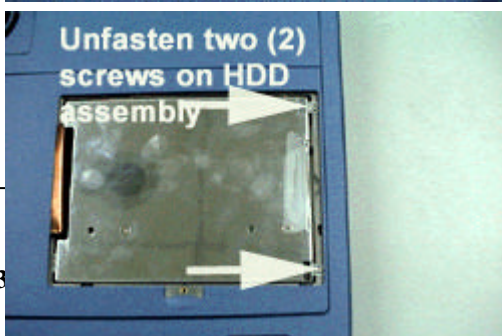

6. Make sure the CPU socket is in release position before you remove the CPU.

7. Unfasten one (1) screw on the HDD cover.

8. Unfasten two (2) screws on the HDD metal bracket.

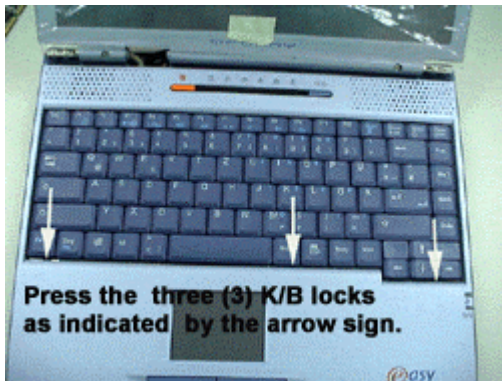
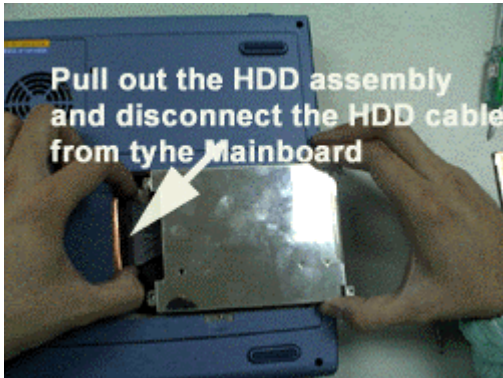

9. Pull out the HDD assembly and disconnect the HDD cable from the mainboard.

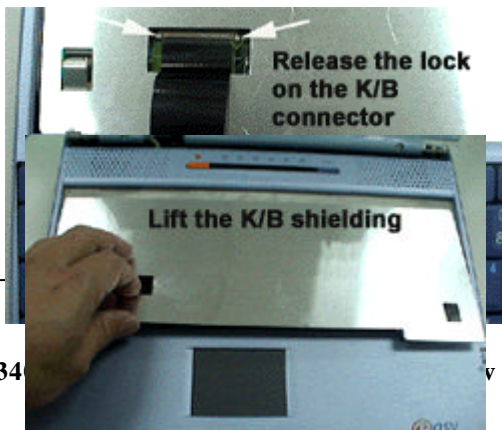

10. Use a small flat screwdriver , insert to the K/B lock to release the three lock.

11. Gently lift the keyboard and disconnect the keyboard cable from the connector.

12. Remove the keyboard shielding or plate.

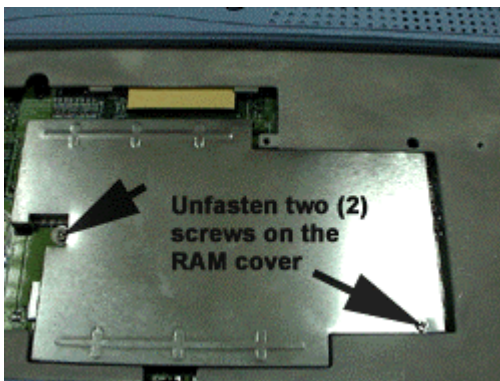

13. Unfasten two (2) screws on the ram cover and remove the RMA cover.

14. Use both thumbs, push in and remove the left and right hinge covers.

15. Close the display panel, press down the middle cover and then pull out to remove.

16. Unfasten one screws of the CD-ROM ( or DVD-ROM drive).

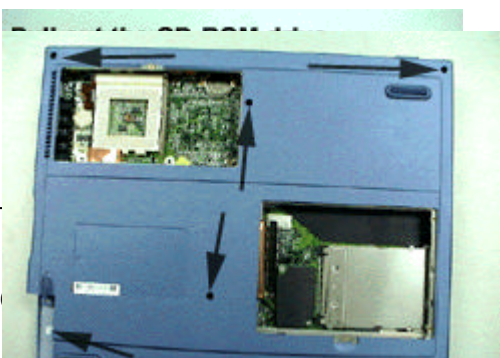

17. On the bottom case, push out the CD-ROM drive as shown in the photo.



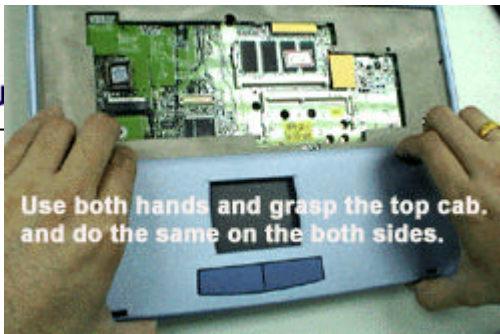

18. Unfasten six (6) screws on the bottom case.

19. Grasp the top cabinet as shown in the photo and gently lift to release the snap lock. Do the same procedure on both side of the top cabinet.

20. After releasing the snap lock on both side and palm rest. Lift up to release and remove the top cabinet.

21. Close the display panel and unfasten four (4) screws on both sides of the display hinges.

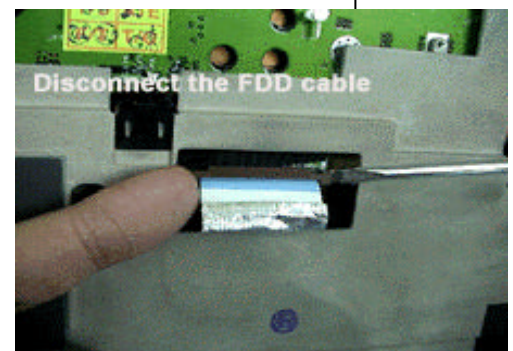
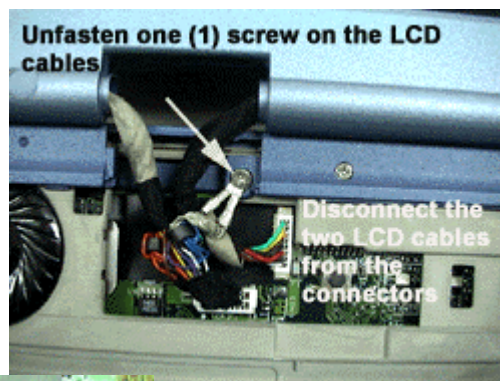
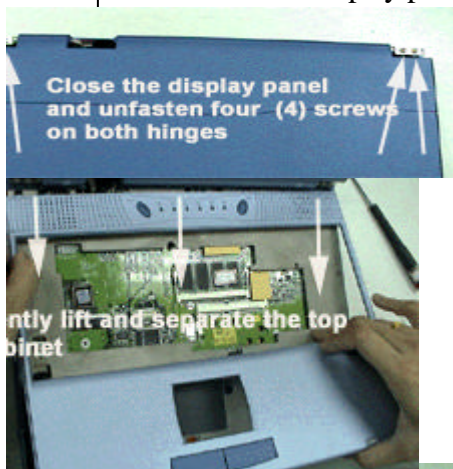

22. Unfasten one (1) screw on the LCD cable and disconnect the two LCD cables from the mainboard connectors.

23. Unfasten two (2) screws on the hinge frame as shown in the photo.

24. Disconnect the FDD cable.

25. Disconnect the Touchpad cable.

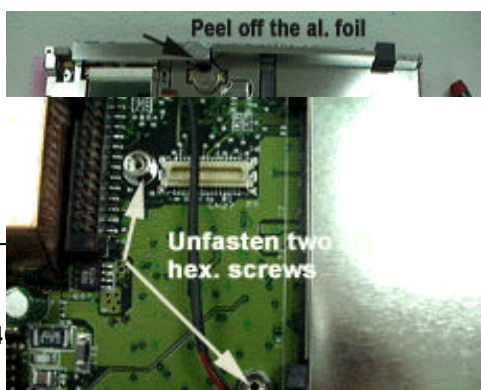

26. Unfasten three screws on the top housing ( Magnesium alloy). To remove the mainboard together with the top housing, push in the

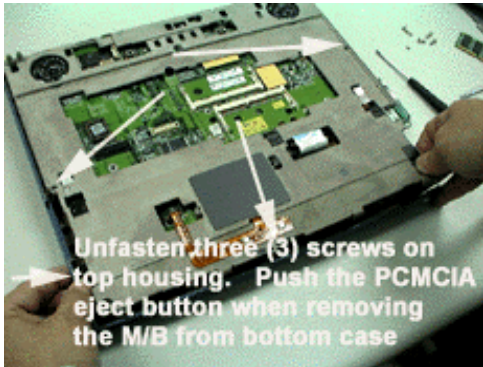

together with the top housing, push in the PCMCIA eject button and on the other hand, lift the mainboard assembly and separate it from the bottom case.

27. At the bottom side of the mainboard, unfasten two (2) screws on the modem card. And disconnect the modem card from the mainboard.

28. Unfasten the two (2) hexagonal screws of the modem card.

29. On the bottom side of the mainboard, unfasten four (4) screws on the mainboard shielding and peel off the aluminum foil near the I/O port as shown in the picture.

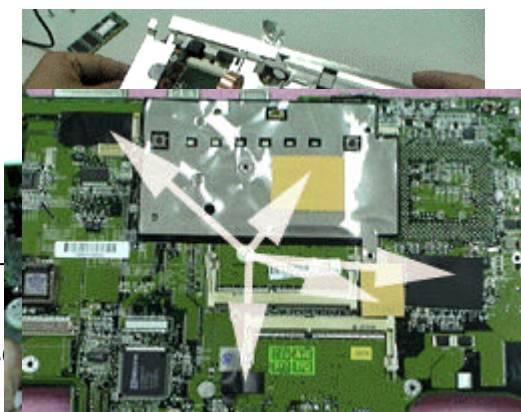
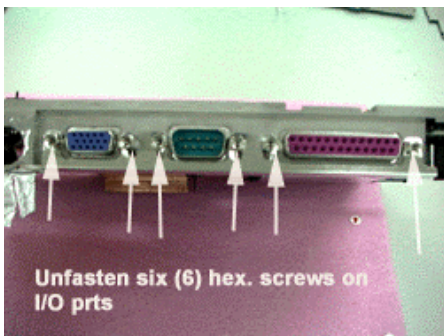

30. From the I/O port, unfasten six (6) hexagonal screws on the I/O ports.

31. Starting from the I/O port portion, flip over the mainboard shielding.

32. Lift the mainboard and disconnect the speaker cable and LID switch cable.

33. When replacing mainboard, make sure to have all the insulation and thermal pads

removed from the defective mainboard and transfer it to a good mainboard ( because sometimes, the good mainboard doesn't have all the tapes and thermal pad as indicated in the photo).

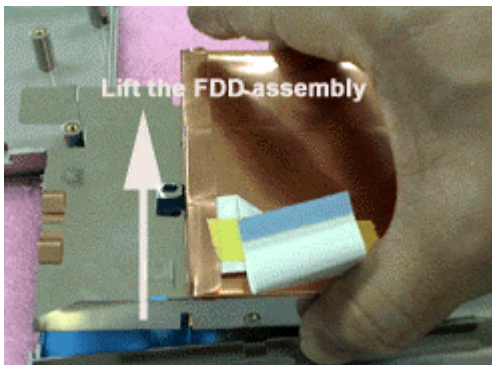
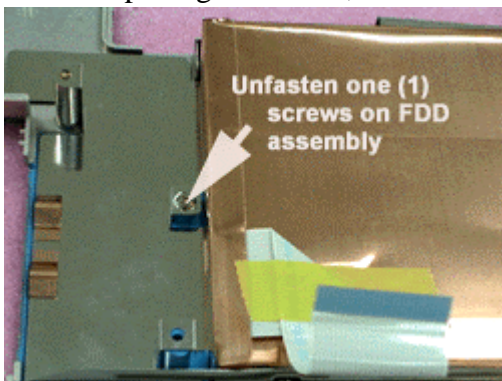



34. Unfasten one (1) screw on the FDD assembly.

Lift to remove the FDD assembly from the bottom case.

### Display Disassembly Procedure



1. Remove the four rubber stopper on the front display cover and unfasten four (4) screws underneath.

Grasp and remove the display front cover.

2. Unfasten two (2) screws on the D-A inverter card and disconnect the cables on both sides.

3. Unfasten four (4) screws on the LCD display and unfasten four (4) screws on both side of the hinges.

Remove the LCD from the display cover.

Make sure to remember the LCD cable arrangement to avoid problem when assembling the LCD display.

# Notebook PC Service Manual

# **Chapter 5**

## ***Trouble Shooting***

UNIWILL COMPUTER CORP.  
No. 24, Pei Yuan Rd., Chung Li Industrial Park  
Chung Li City, Taiwan, R.O.C.  
TEL: 886-3-461-6000  
FAX: 886-3-461-8000  
URL: <http://uniwill.com.tw/>

**Trouble Shooting List**

- 5.1 No display**
- 5.2 VGA controller failure**
- 5.3 LCD no display / Invalid picture**
- 5.4 External monitor has no display or color incorrect**
- 5.5 Memory test error**
- 5.6 Keyboard test error**
- 5.7 Touch pad test error**
- 5.8 Diskette drive test error**
- 5.9 Hard disk drive test error**
- 5.10 CMOS test error**
- 5.11 SIO port test error**
- 5.12 PIO port test error**
- 5.13 Audio failure**
- 5.14 No power symptom**
- 5.15 CDROM drive test error**
- 5.16 Stopping in LCD screen while booting**
- 5.17 PCMCIA Card Bus failure**
- 5.18 IR Port cannot transfer data**
- 5.19 Modem Failure**

**5.1 No display (system failure)**

Symptom: There is no display on both LCD and Monitor after power on although the LCD and Monitor are known-good.

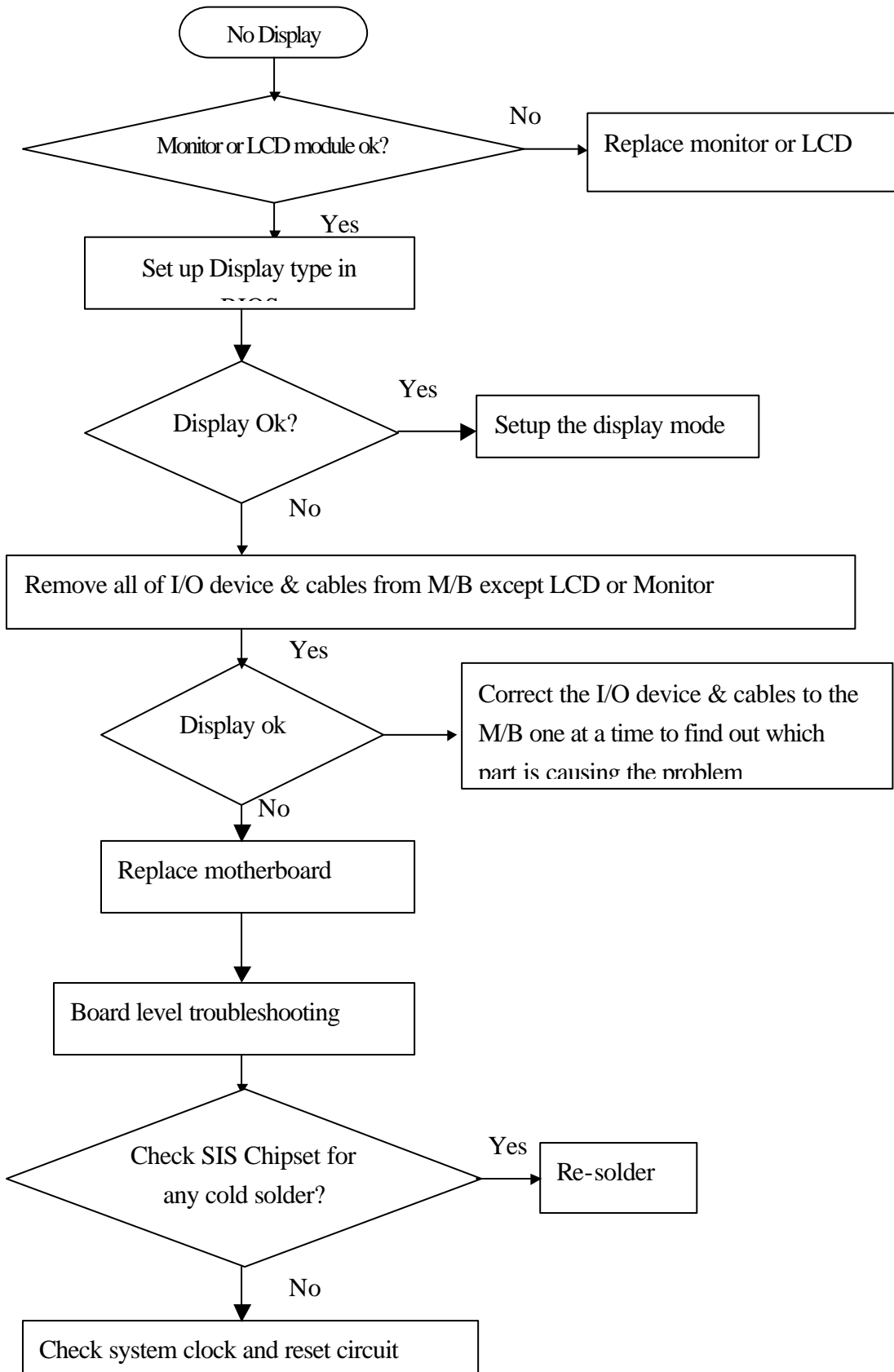

**5.2 VGA controller failure**

Symptom: There is no display on both LCD and Monitor although Power-On-Self-Test is passed

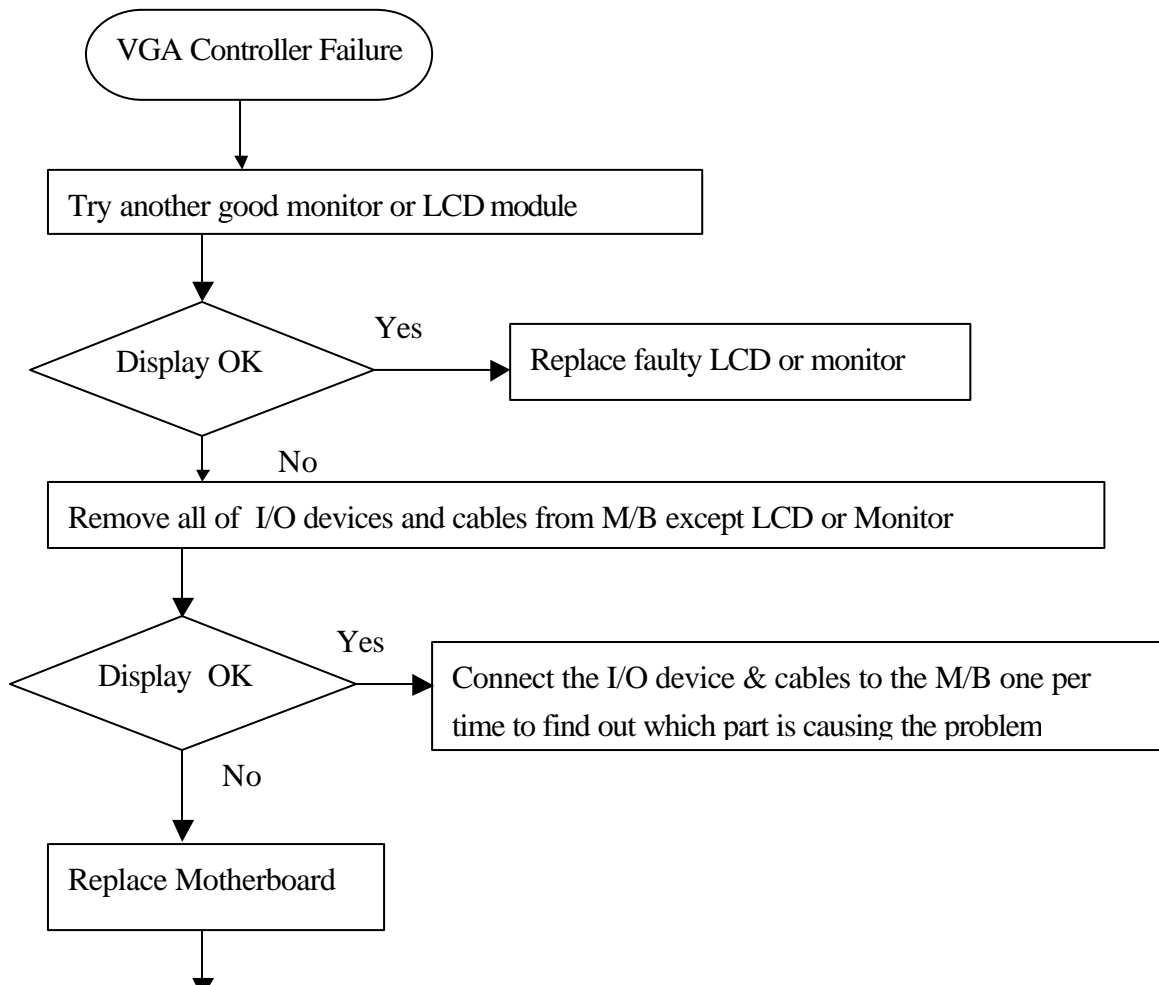

**5.3 LCD no display or Invalid Picture**

Symptom: The LCD shows nothing or abnormal picture, but it is ok for external monitor.

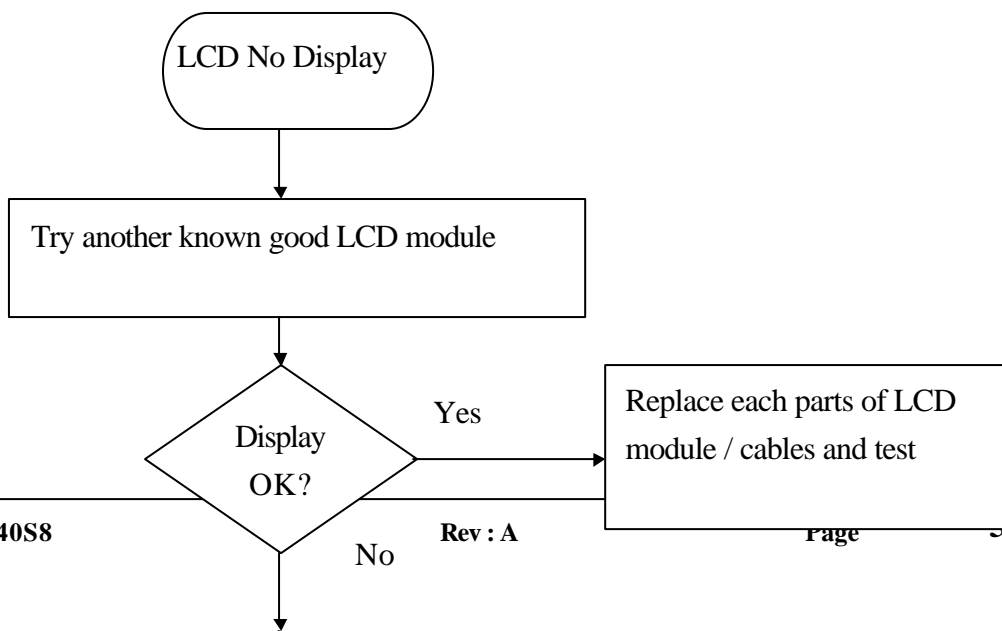



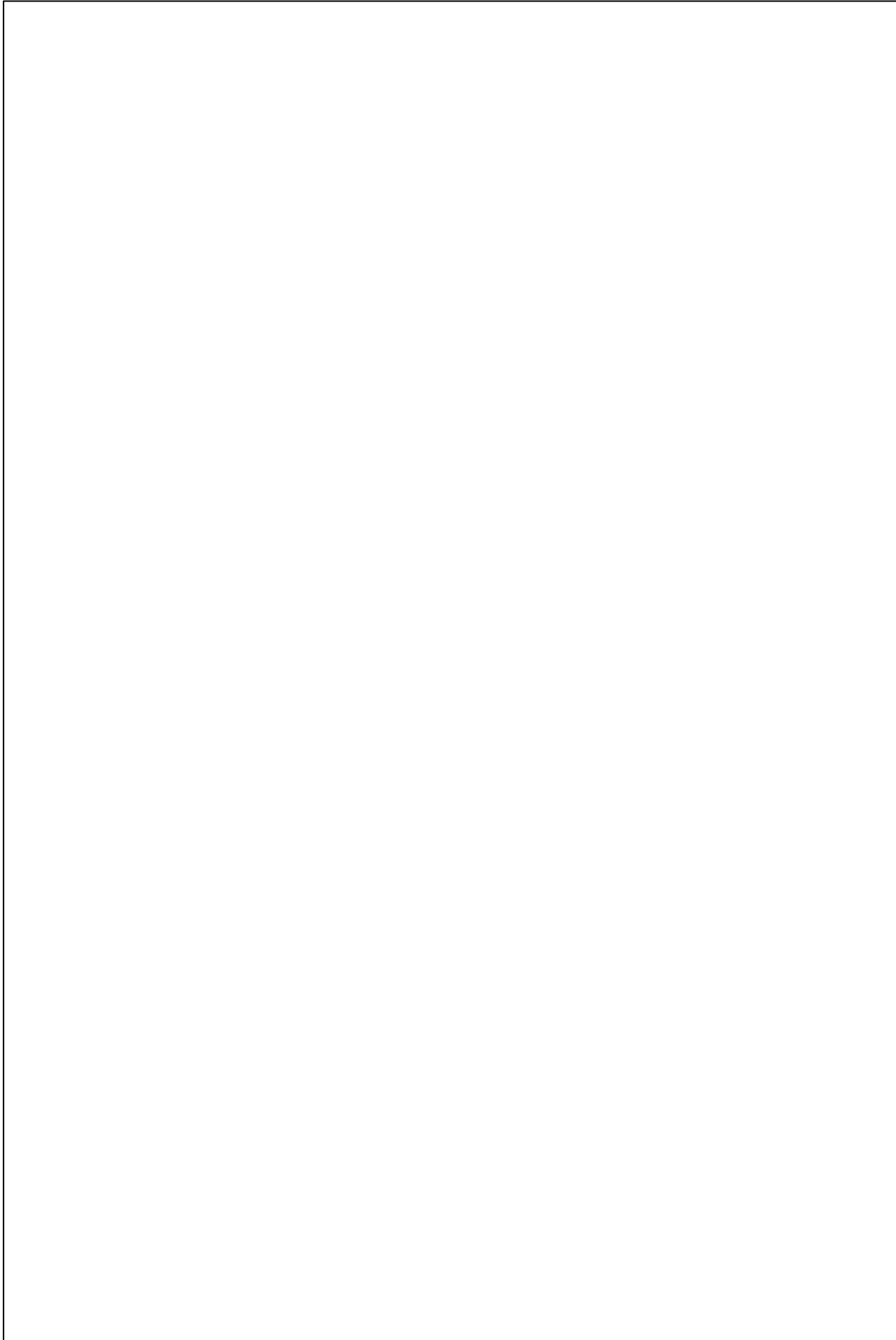

**5.4 External monitor has no display or color abnormal**

Symptom: The CRT monitor shows nothing or abnormal color, but it is ok for LCD

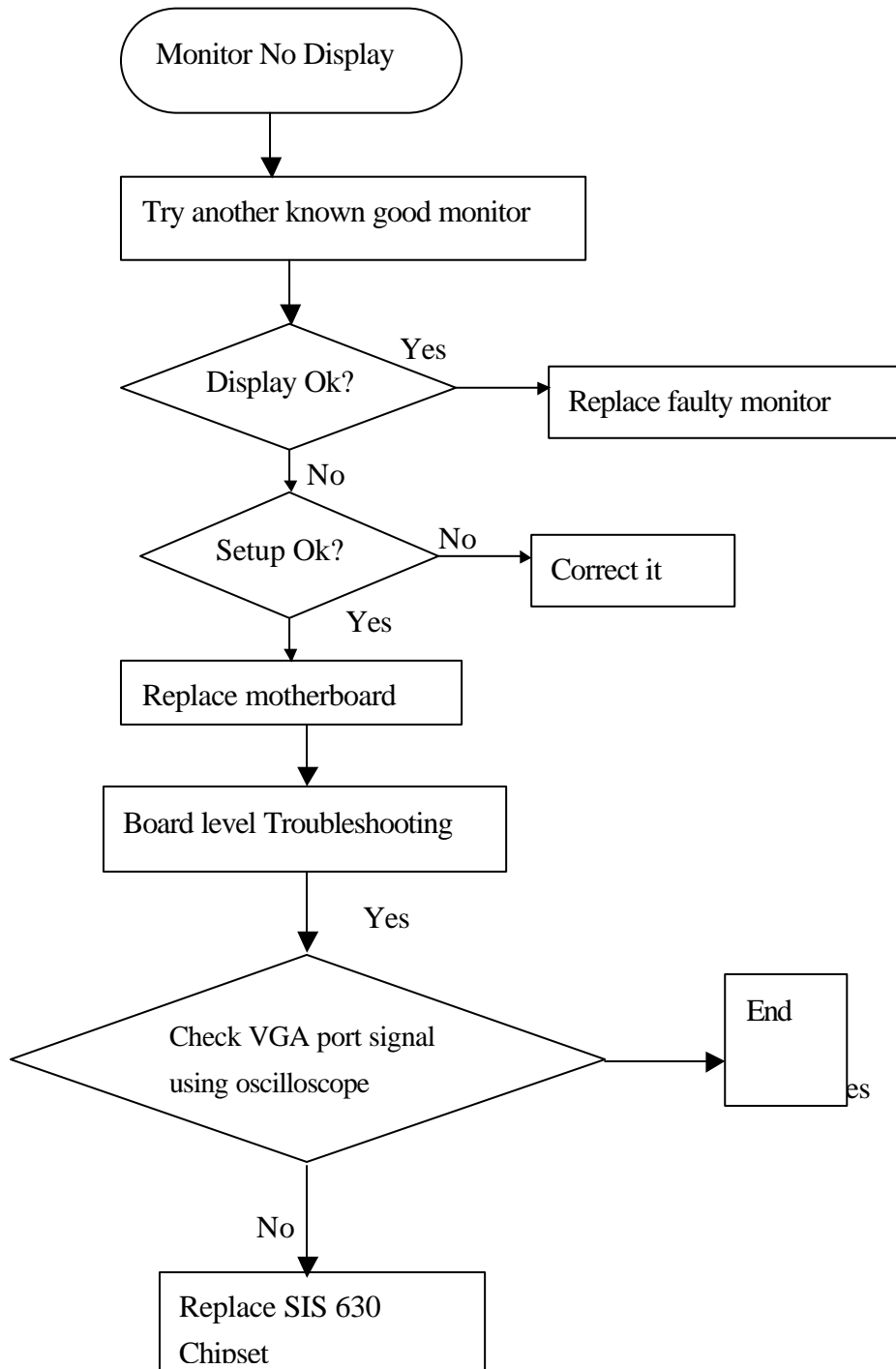

5.5 Memory test error

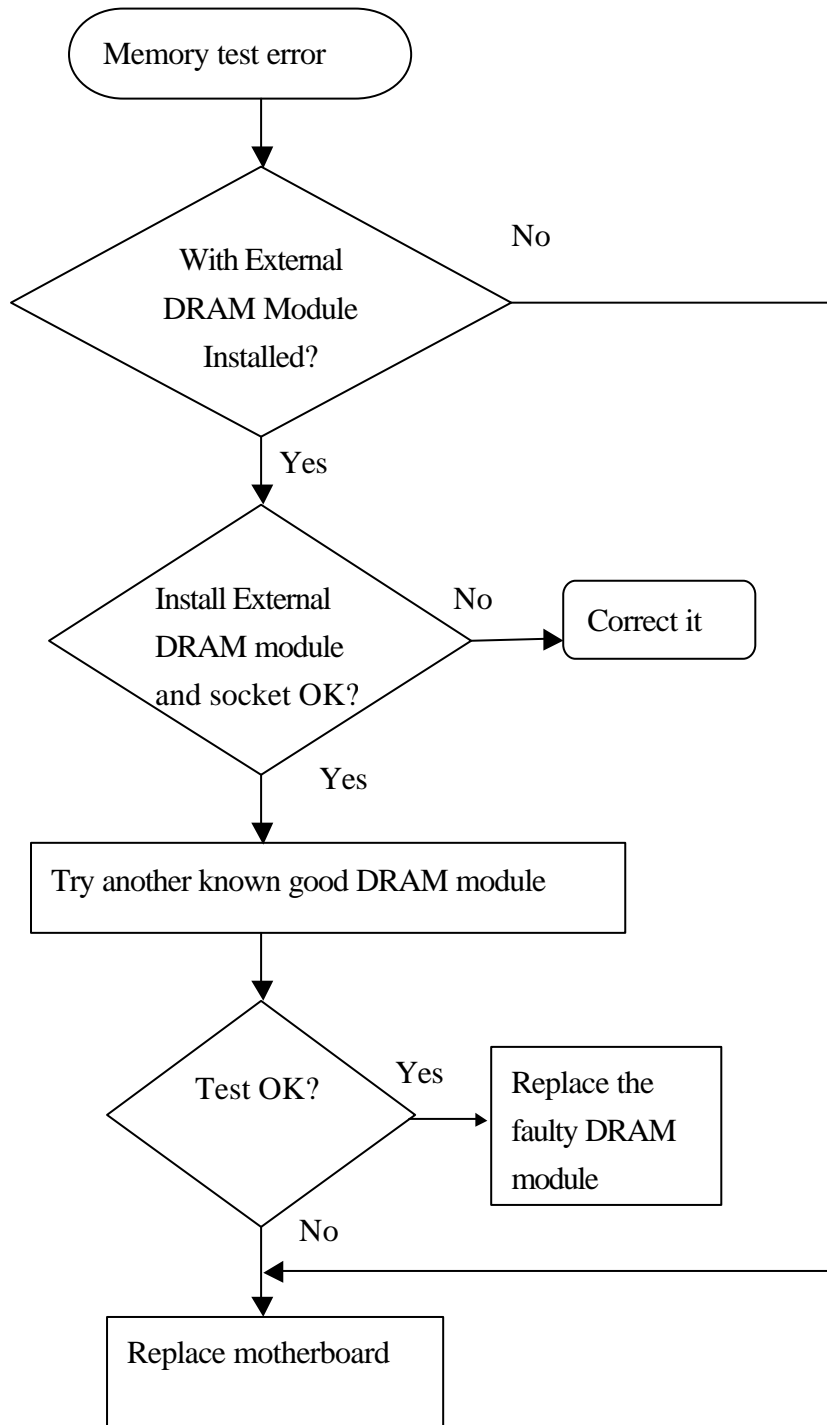

**5.6 Keyboard test error (including external K/B & PS/2 mouse)**

Symptom: error message of keyboard failure is shown or any key doesn't work

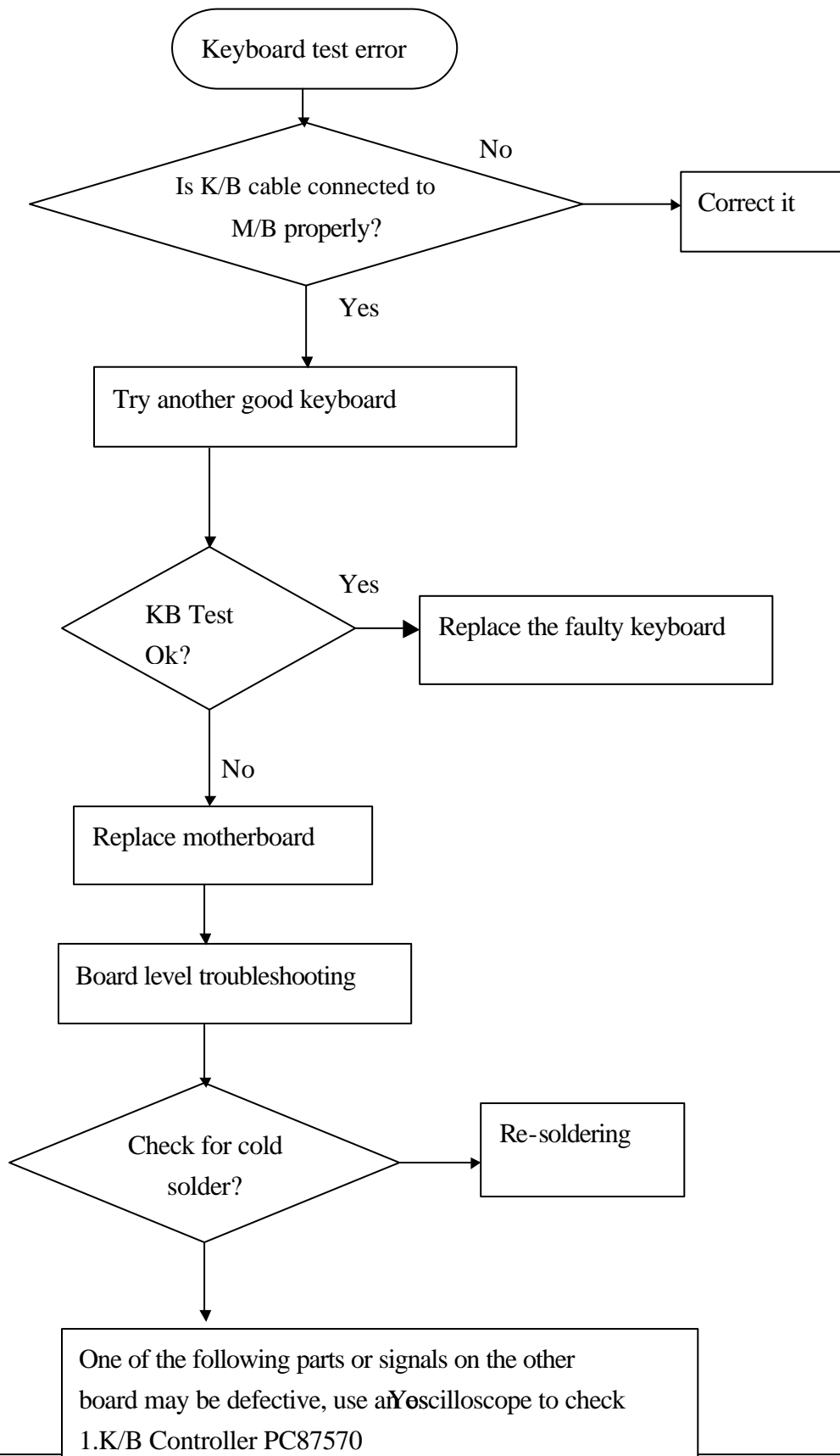

5.7 Touch Pad test error

Symptom: An error message is shown when the Touch Pad point is enabled

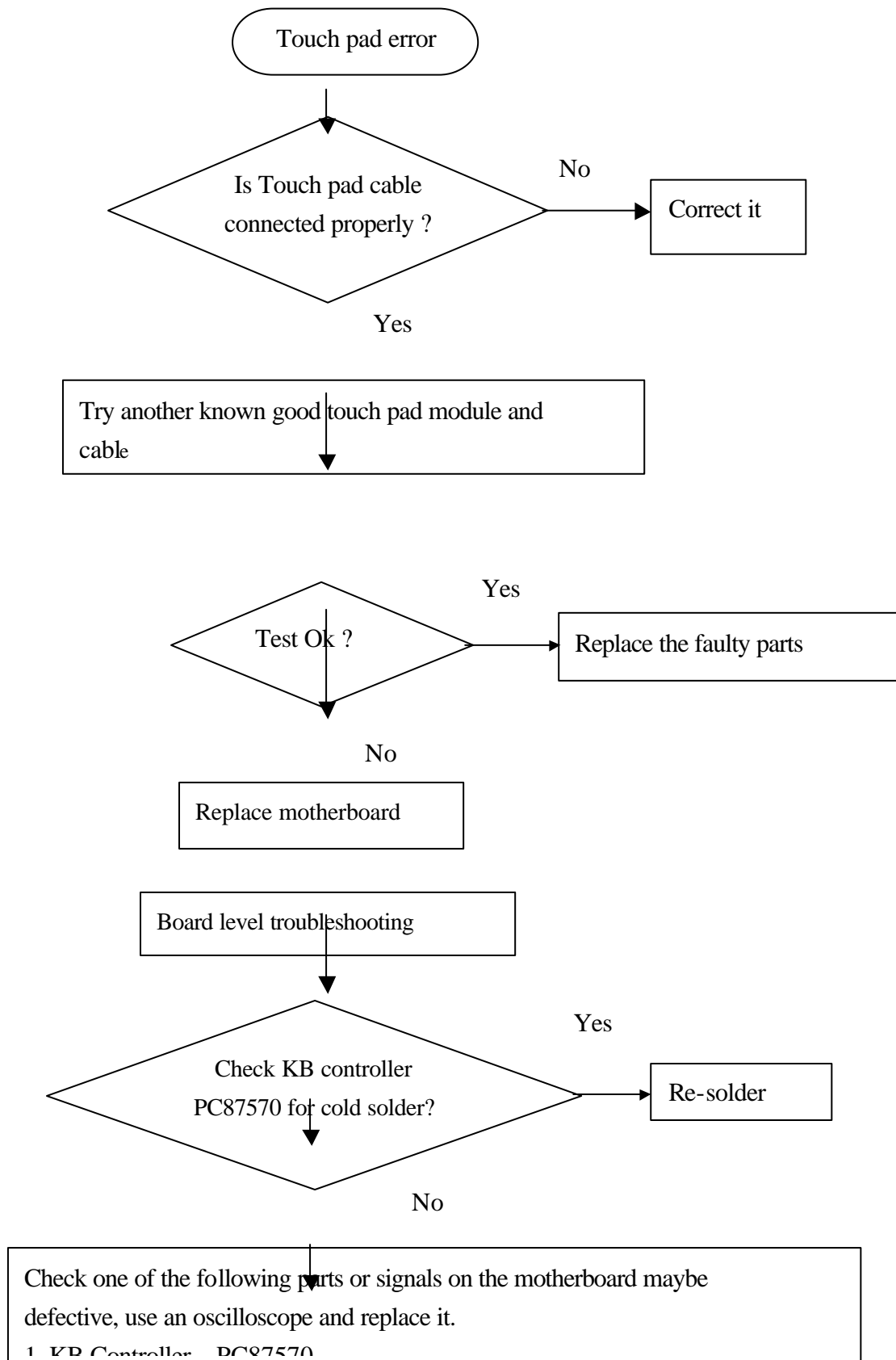



**5.8 Diskette drive test error**

Symptom: An error message is shown while loading data from FDD to system

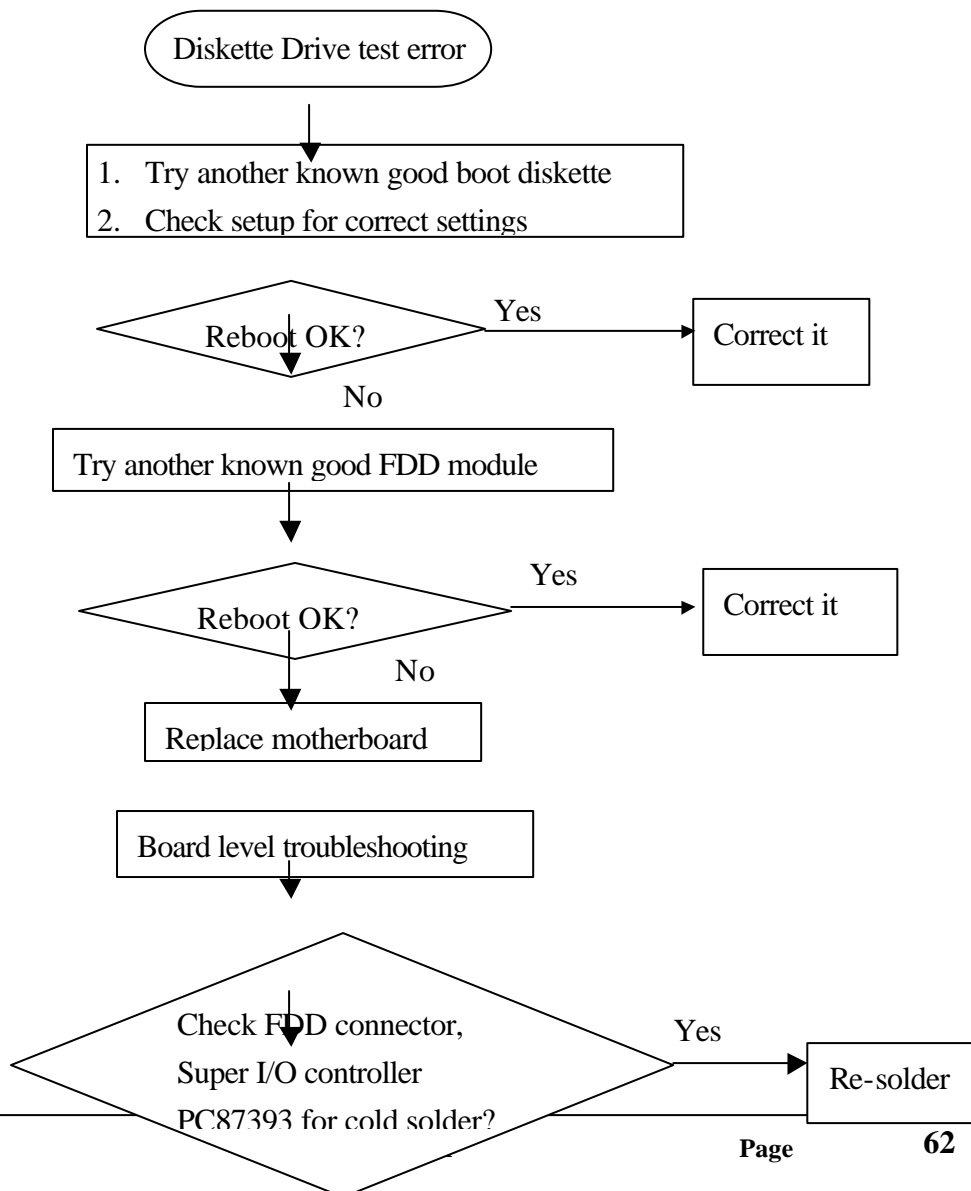



**5.9 Hard disk drive test error**

Symptom: Either an error message is shown, or the drive motor spins non-stop, while reading data from or writing data to Hard disk

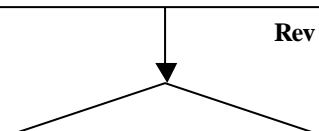
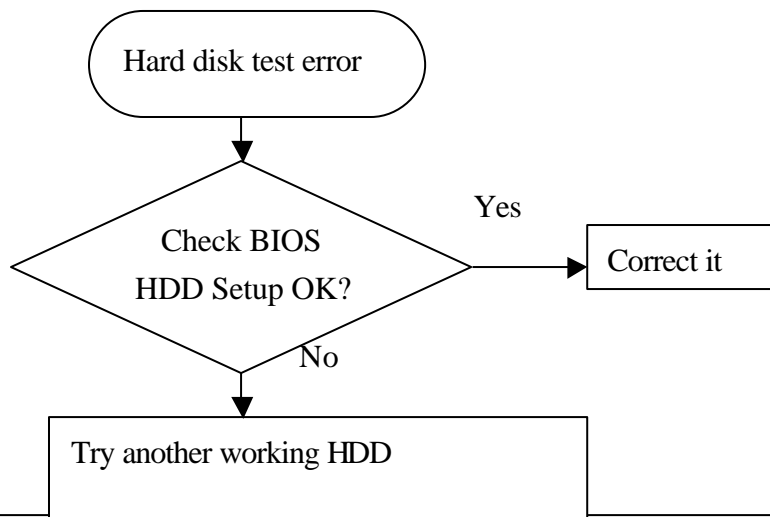

Yes

Replace the faulty parts

**5.10 CMOS test error**



1. CMOS data lost, or inaccurate system time & data

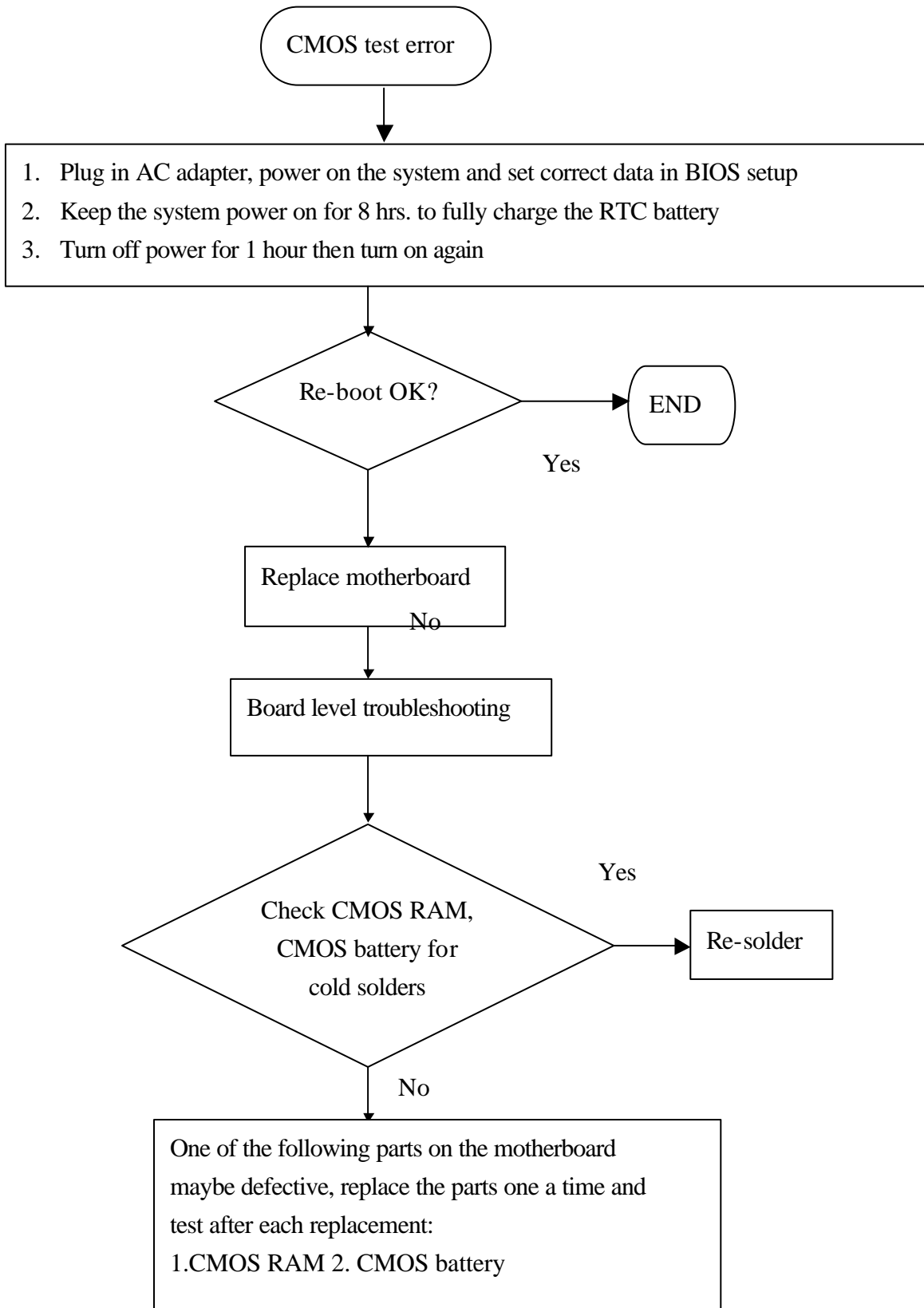

**5.11 SIO port test error**

Symptom: An error display occurs when a mouse or other I/O device is installed

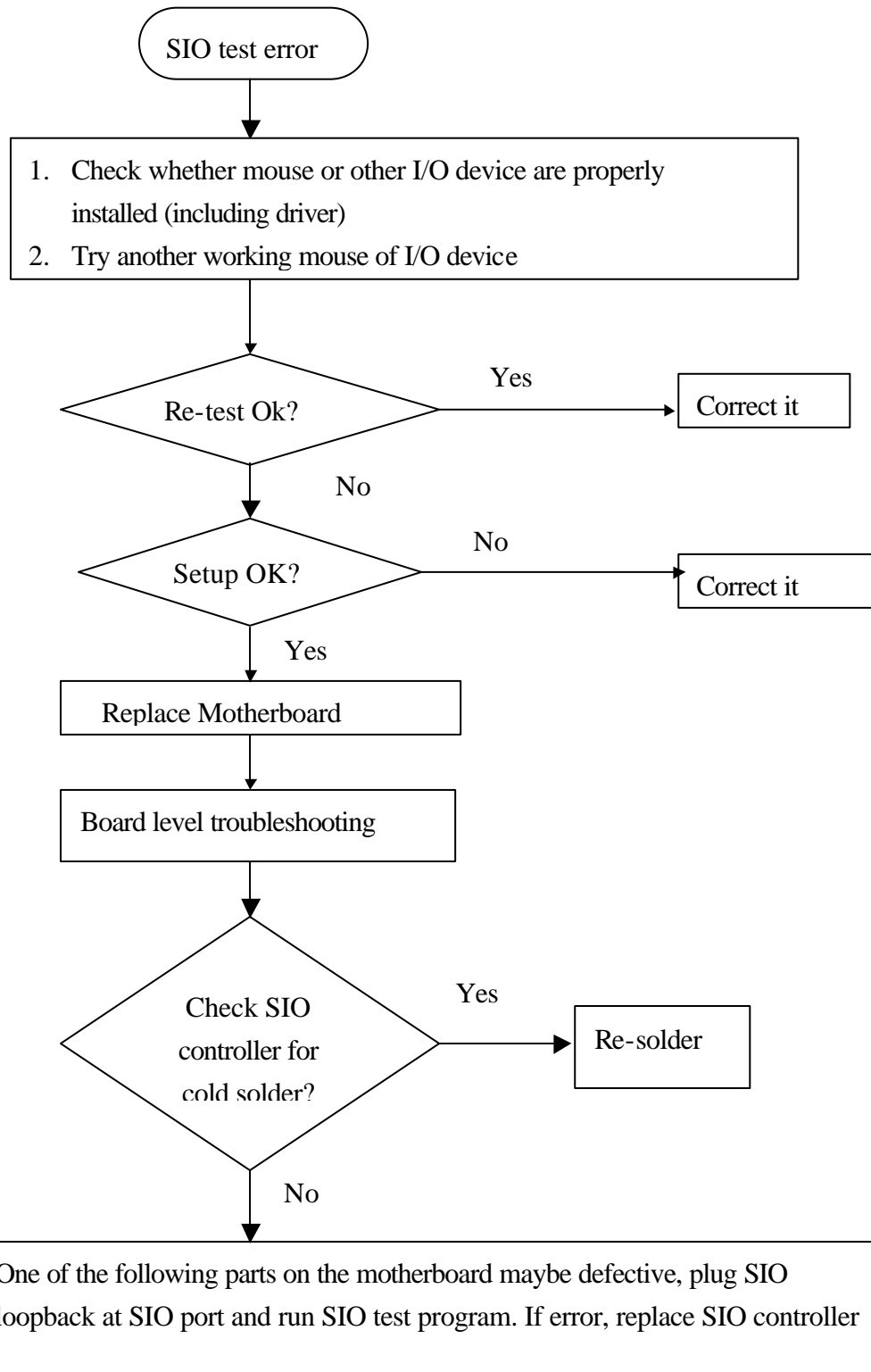

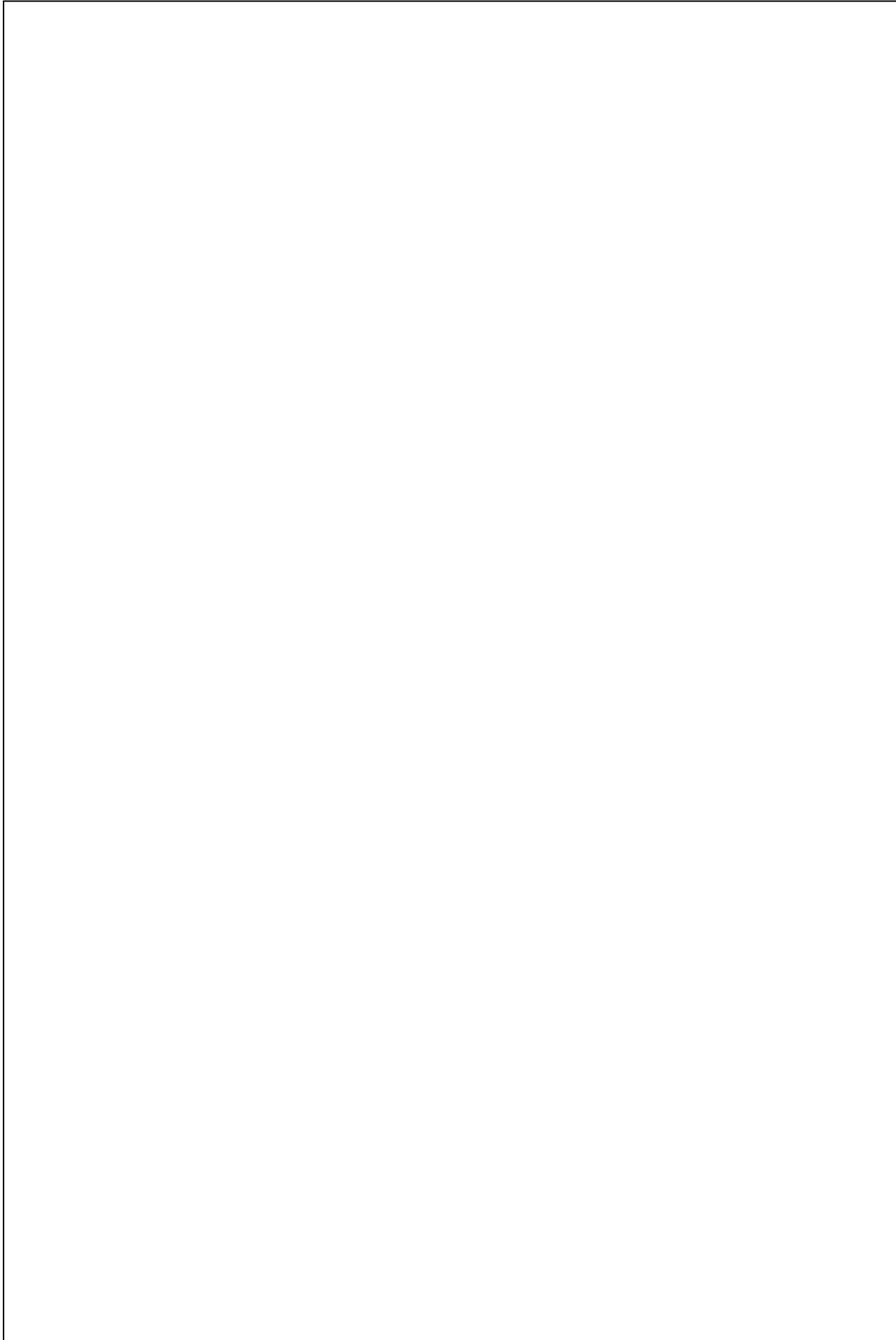

**5.12 PIO port test error**

Symptom: When a print command is issued, printer prints nothing or garbage.

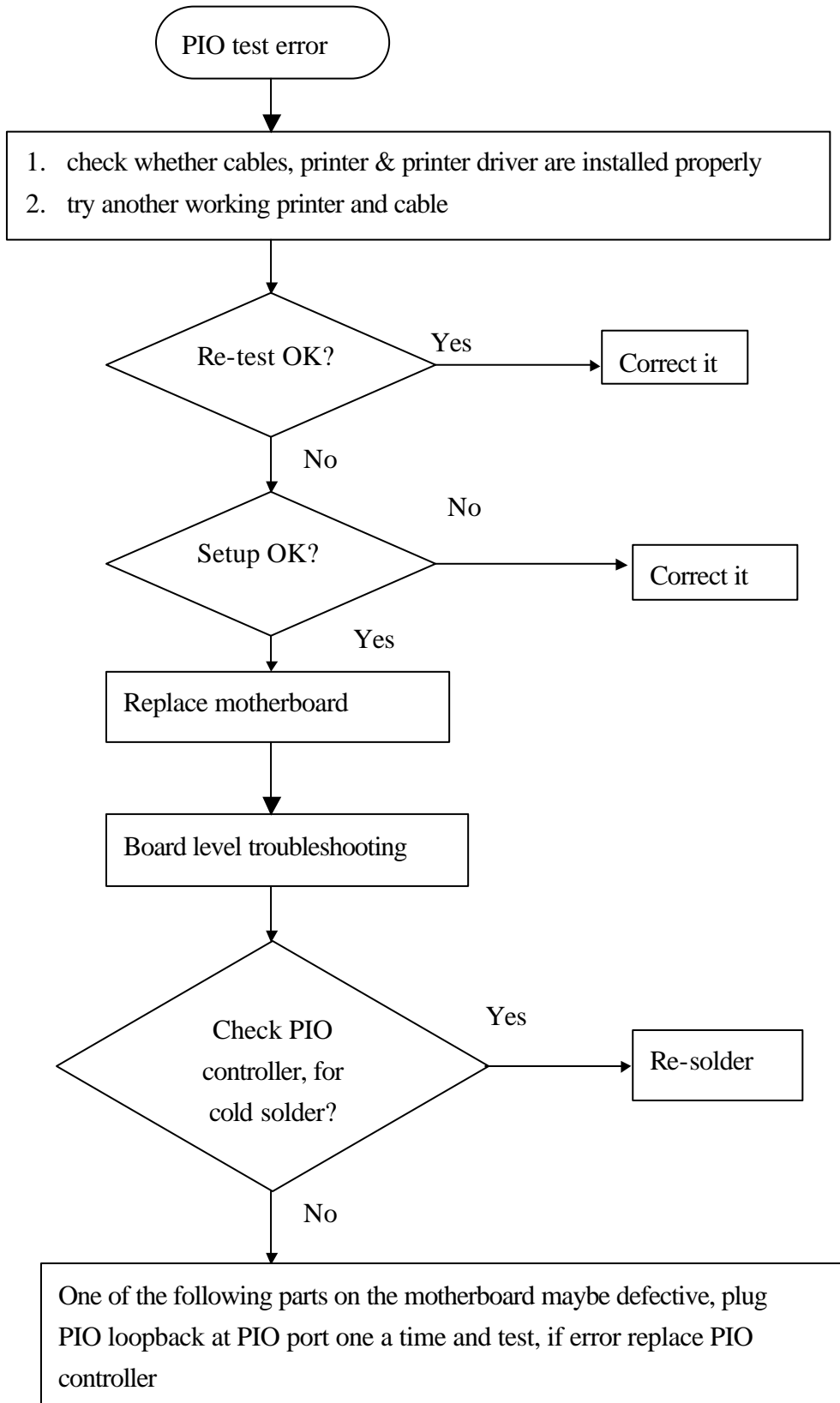

**5.13 Audio failure**

Symptom: No sound from speaker after audio drive is installed.

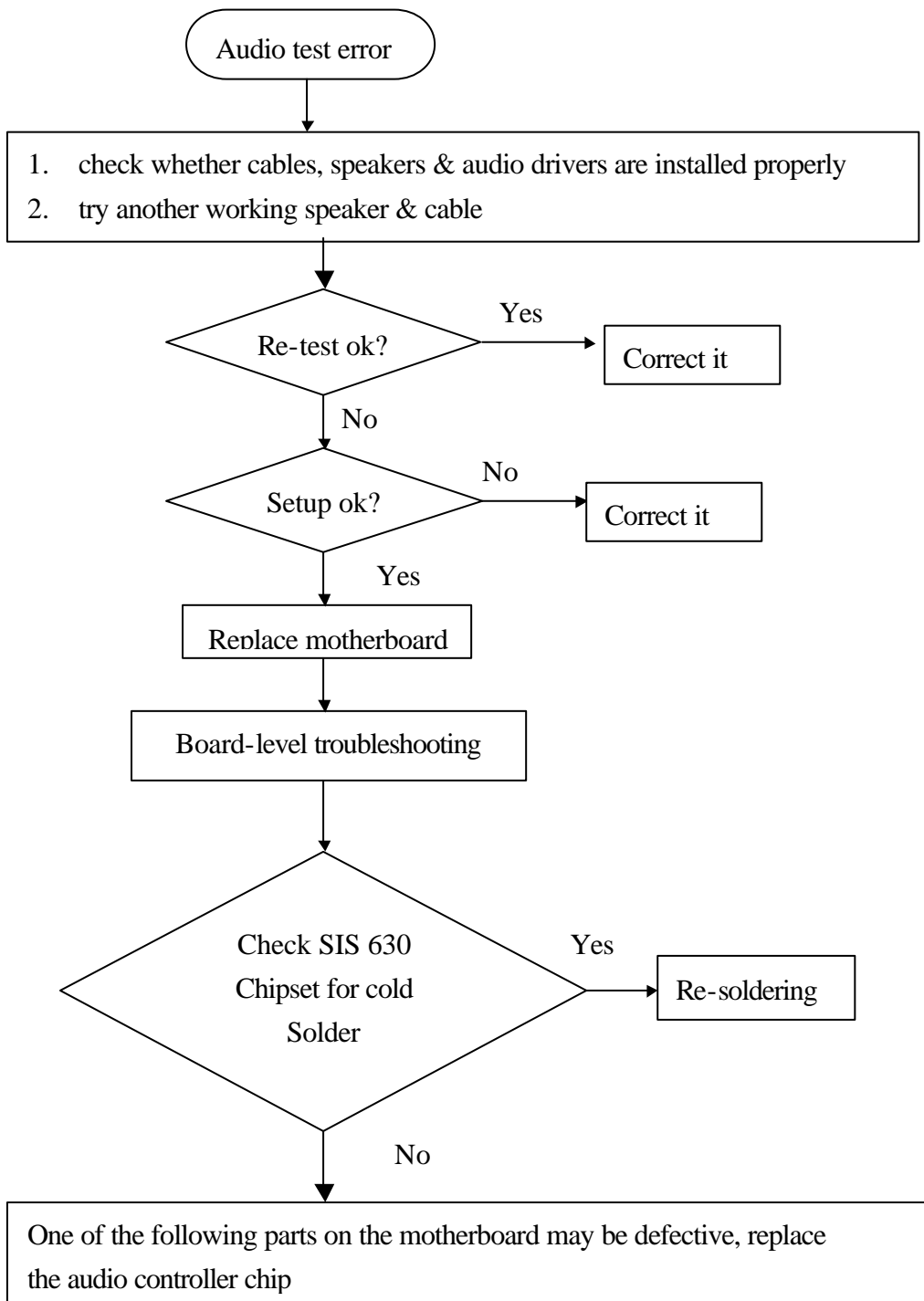

**5.14 No power symptom:**

Symptom: When the power button is pressed, nothing happens, power indicator is not light up.

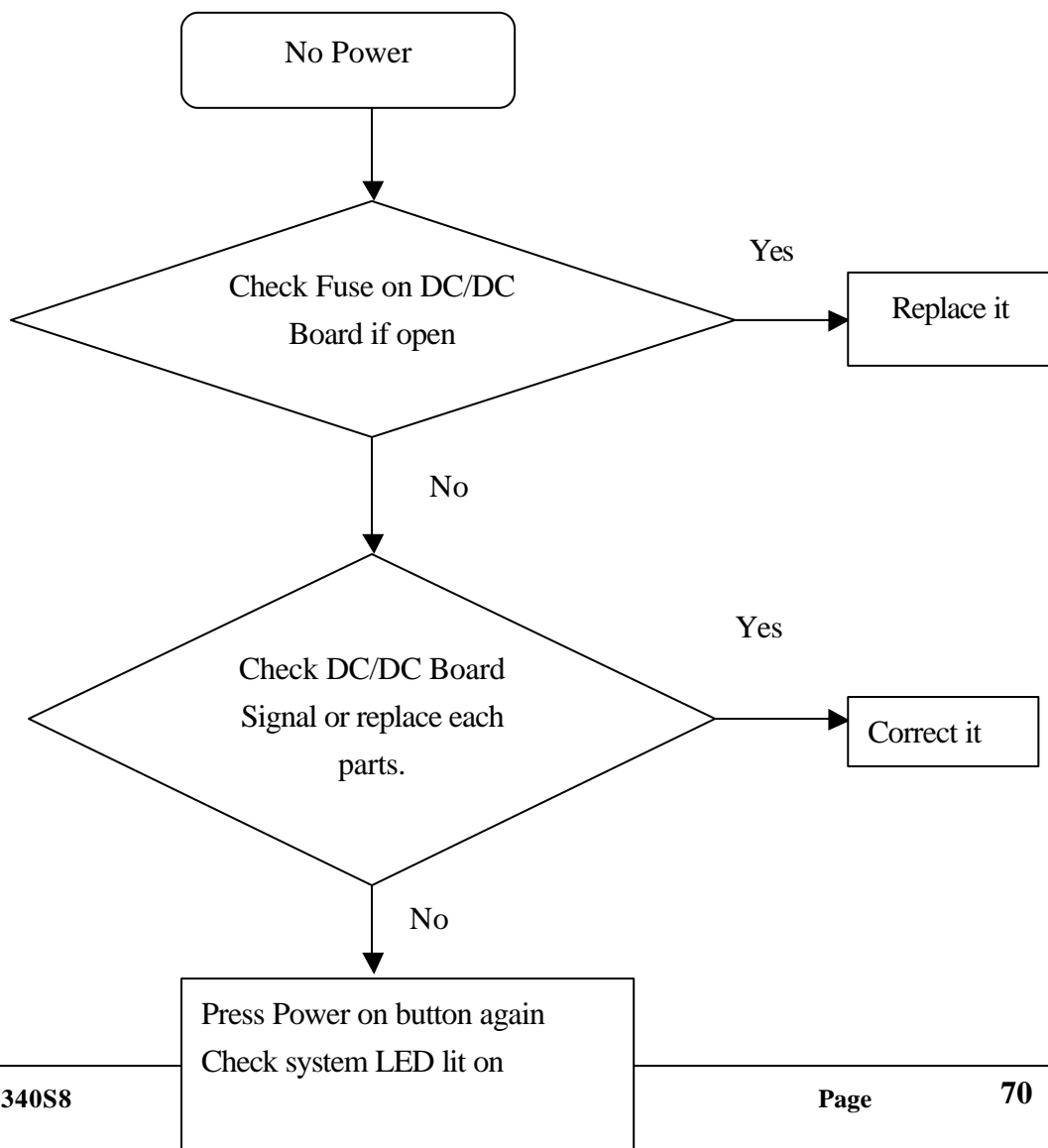

**5.15 CD-ROM drive test error**

An error message is shown when reading data from CD-ROM drive

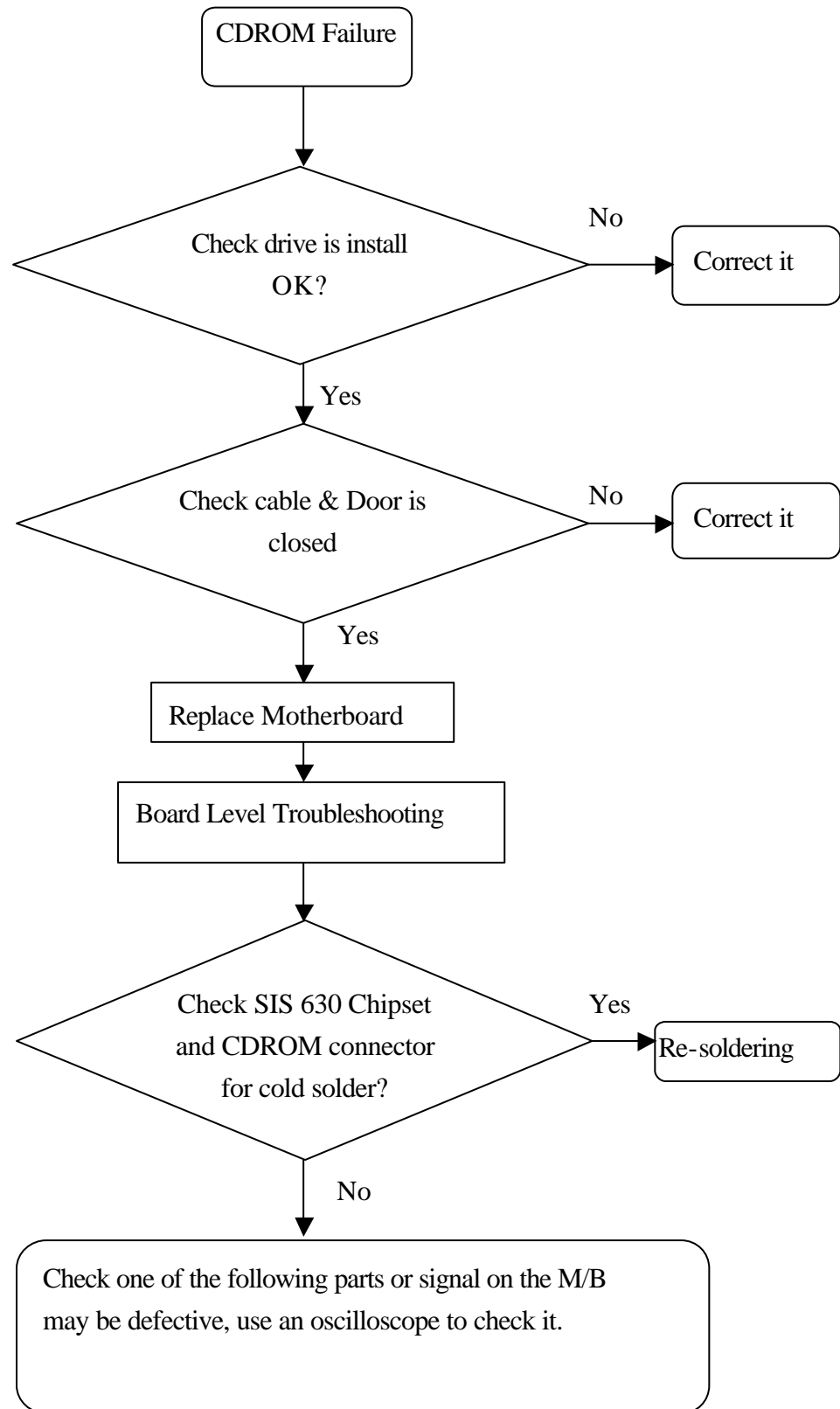

5.16 Stopping in LCD screen while booting

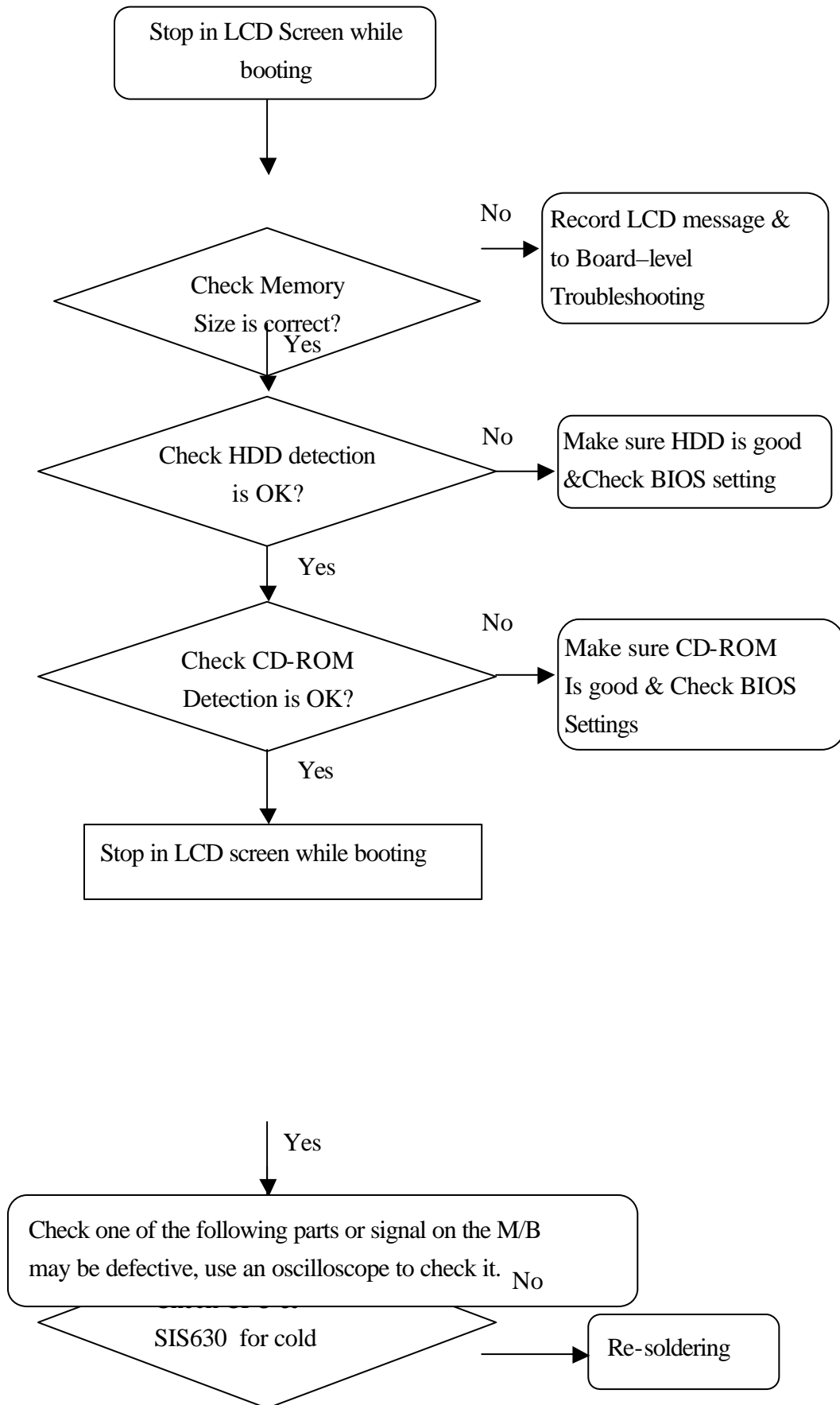



**5.17 PCMCIA CardBus failure**

**Symptom :** when insert PCMCIA card to PCMCIA slot, but system can't detect.

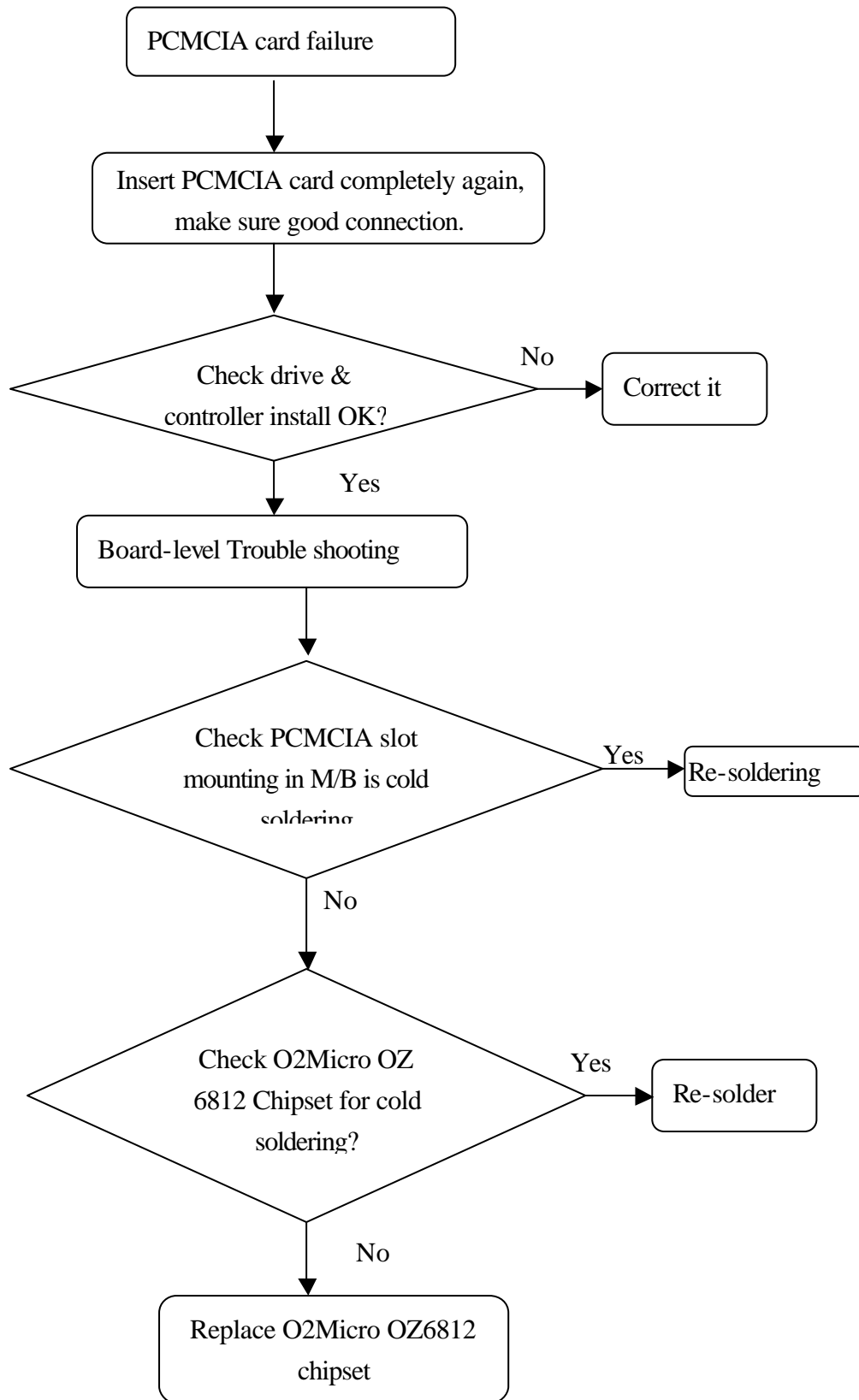

5.18 IR Port can't transfer data.

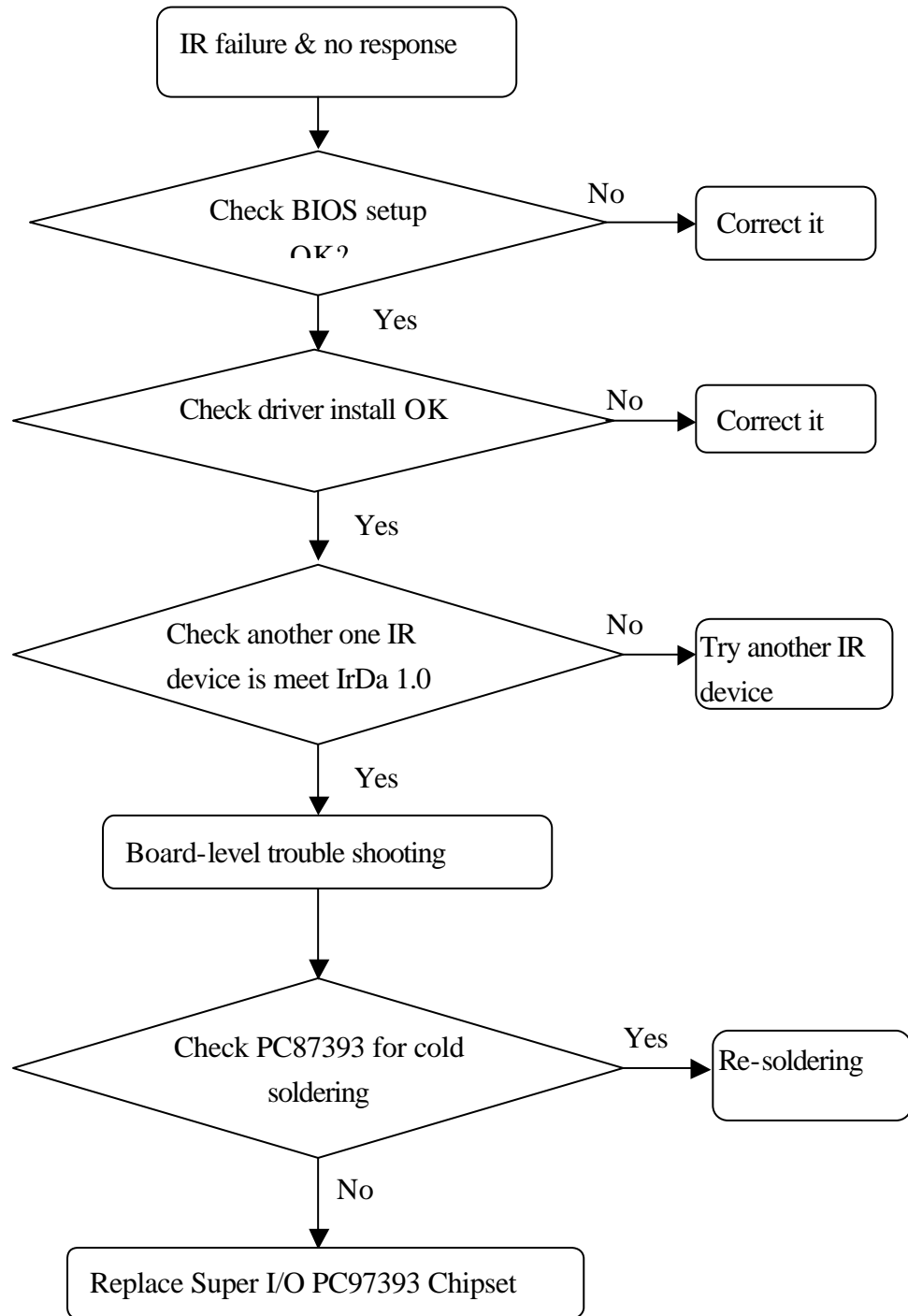

### 5.19 Modem failure

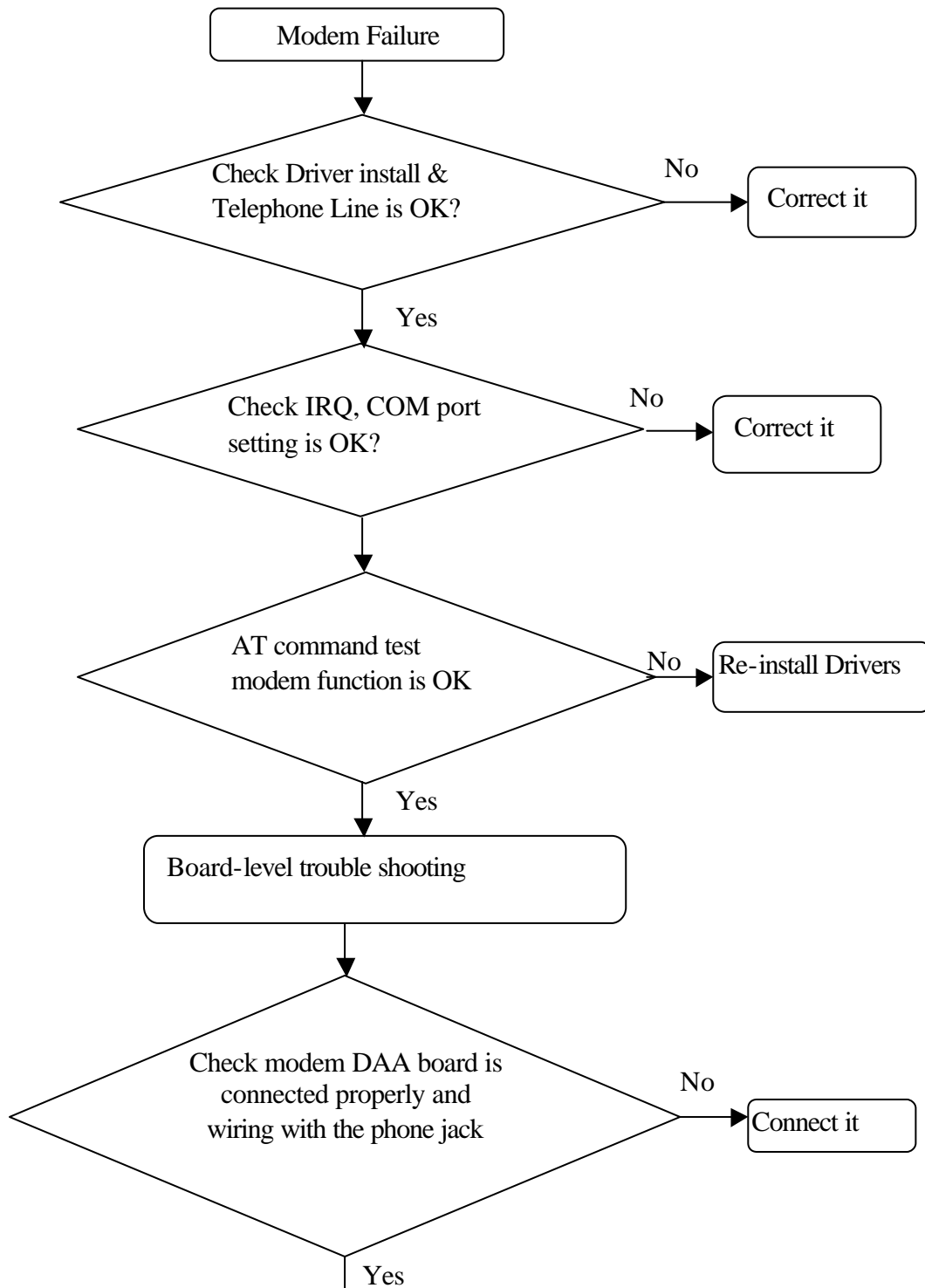

Notebook PC Service Manual

# **Model: 340S8**

## **Chapter 6**

# **Peripheral Devices**

UNIWILL COMPUTER CORP.  
No. 24, Pei Yuan Rd., Chung Li Industrial Park,  
Chung Li City, Taiwan, R.O.C.  
TEL: 886-3-461-6000  
FAX: 886-3-461-6317  
URL: <http://www.uniwill.com.tw/>

## 6.1 LCD

- I. 14.1" TFT, XGA - Vendor – UNIPAC, CHI MEI,
- II. 13.3" TFT, XGA – Vendor – ACER, IMES
- III. 12.1" TFT, SVGA – Vendor – Sanyo, Torisan

## 6.2 FDD

Internal FDD: 3.5" format  
Capacity : 720KB / 1.44MB / 1.2MB (3 mode)  
Vendor : TEAC or MITSUMI

## 6.3 HDD

Dimension : 2.5", 8.5 / 9.5 mm height  
Vendor : Toshiba, and Fujitsu

## 6.4 CD-ROM

Vendor : QMATE, TEAC  
Dimension : 12.7-mm height, 12/8 cm CD-ROM disc  
PIO Mode 4, 24X  
Average 3.1W, Sleep 0.05W  
ATAPI Interface

### DVD

Vendor : TORISAN, TOSHIBA, QMATE  
Dimension : 12.7mm height, 12/8cm CD-ROM disc  
PIO Mode 4  
Average 3.1W, Sleep 0.05W  
ATAPI Interface

## 6.5 BATTERY:

### Li-ION

Vendor : PANASONIC , GS  
Battery type : Li-Ion, 8 cells (4S2P)  
Battery capacity : 14.8V, 3600mAh, (47.36Whrs)

#### 1.1.1. Charge Voltage : 16.8V +2.5% -1.0%

Charge temperature : 0~45°C

Discharge temperature : -20~60°C

End of Discharge : 11V

Cycle life= 500 times

Overcharge protection : when battery voltage reach 17.2 ±0.2V

Over-discharge protection : when battery voltage decrease to 10 ± 1V

Pre-charge current: 0.2A

Charge current : When system is power off : 2A  
When system is powered ON : 1A

### Ni-MH

Vendor : PANASONIC, TOSHIBA

Battery Type : Ni-MH, 10 cells (10S)

Battery Capacity : 12.0V, 4500mAh (54.0 watts)

Charge voltage : 16.8V +2.5% -1.0%

Charge temperature : 0~45°C

Discharge temperature : -20~60°C  
End of Discharge : 10V  
Cycle life= 500 times  
Pre-charge current: 0.2A  
Charge current : When system is power off : 2A  
When system is powered ON : 1A

## 6.6 TOUCH PAD

Synaptic  
Capacitor sensor  
Support edge motion  
Support virtual scroll bar  
Support 2 or 3 button mode  
ESD withstand: 15KV  
Power Consumption: 2.75mA / 5V  
X/Y resolution: 500 points/inch  
Interface: PS/2

## 6.7 KEYBOARD

Supplier : KC Matrix-290  
Travel : 3.0 ±0.2mm  
Support : 3 window keys  
Key pitch : 19mm  
Dimension : 249mm x 100.85mm x 7.8 mm

## 6.8 MODEM/FAX MODULE

Modem chip : SamrtLink HAMR5603+Si3014  
Meet PC99 Window modem requirement  
Support :

AMR / MDC slot / V.90 (56Kbps) / AC'97 2.1 / APM & ACPI  
V.34bis (4.8Kbps to 33.6Kbps) /  
V.32 bis (4.8Kbps to 14 Kbps) / AT command set  
V.42 (LAPM) and MNP 2-4 error correction, 5 data compression  
V.22 bis ( 50 bps to 2.4Kbps) / V.21 Bell 103 / Bell 212  
Fax Group3 Class 1/V.17, V.29, V.27ter, V.21 ch2/  
Group III fax / telephony answering machine / DTMF generation and detection  
Local handset, telephone and microphone record / telephone line and headset or  
Peaked playback / VOX voice Detection/ Caller ID (optional) / host base DSVD

**Notebook PC Service Manual**

# **Model : 340S8**

## **Chapter 7** ***Explosion Diagram***

**UNIWILL COMPUTER CORP.**

No. 24, Pei Yuan Rd., Chung Li Industrial Park  
Chung Li City, Taiwan, R.O.C.

TEL: 886-3-461-6000

FAX: 886-3-461-6317

URL: [http:// uniwill.com.tw/](http://uniwill.com.tw/)

## 7.1 TOP CABINET ASSEMBLY

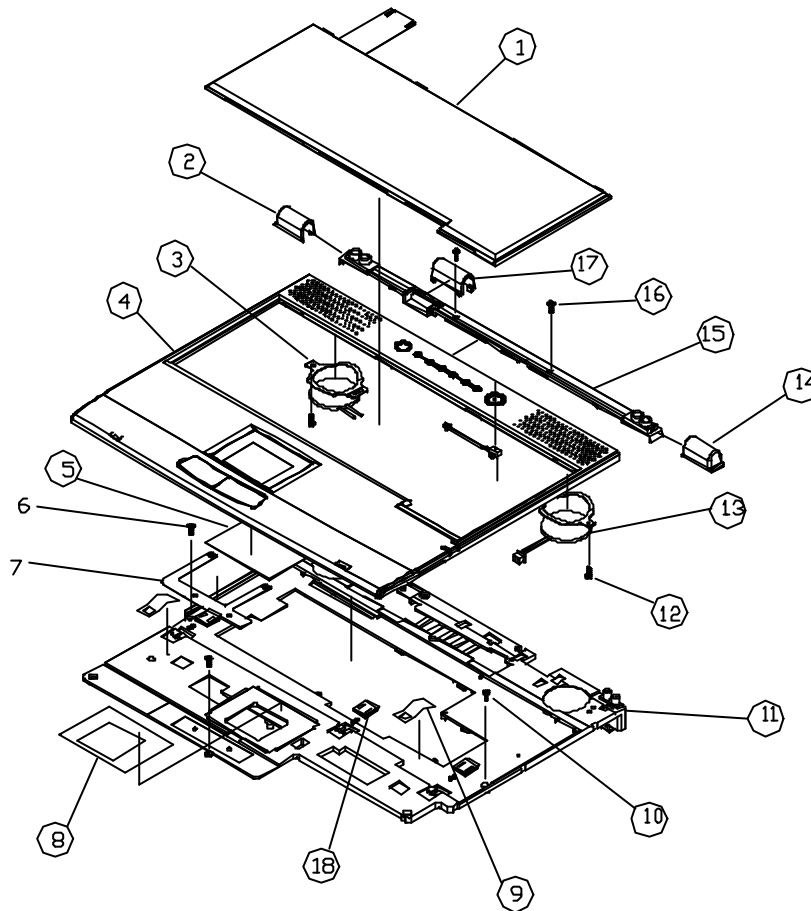

NO.	PART NUMBER	DESCRIPTION
1	71-002941-00 71-002933-00	K/B (GR) Blue K/B (GR) Gray
2	50-352968-00	COVER HINGE (L) 340
3	40-102902-00	SPRING SPK 340
4	50-312942-00 50-312935-00	TOP CABINET ID-2 ID-4
5	74-08U20400	T/P
6	41-720120-06	SCREW M2.0*6
7	29-163402-00	FPC T/P PAD
8	50-212904-00	ADHESIVE TAPE
9	40-102901-00	SPRING FOR K/B 340
10	41-720120-04	M2.0*4
11	50-312903-10	TOP HOUSING (MG) 340
12	41-720120-03	M2.0*3
13	22-300513-10	SPK FG-36N081
14	50-352967-00	COVER HINGE (R ) 340
15	50-352966-00	COVER HINGE FRAME
16	41-720120-03	M2.0*3
17	50-352969-00	COVER CABLE FOR 340



### 7.3 BASE CABINET ASSEMBLY

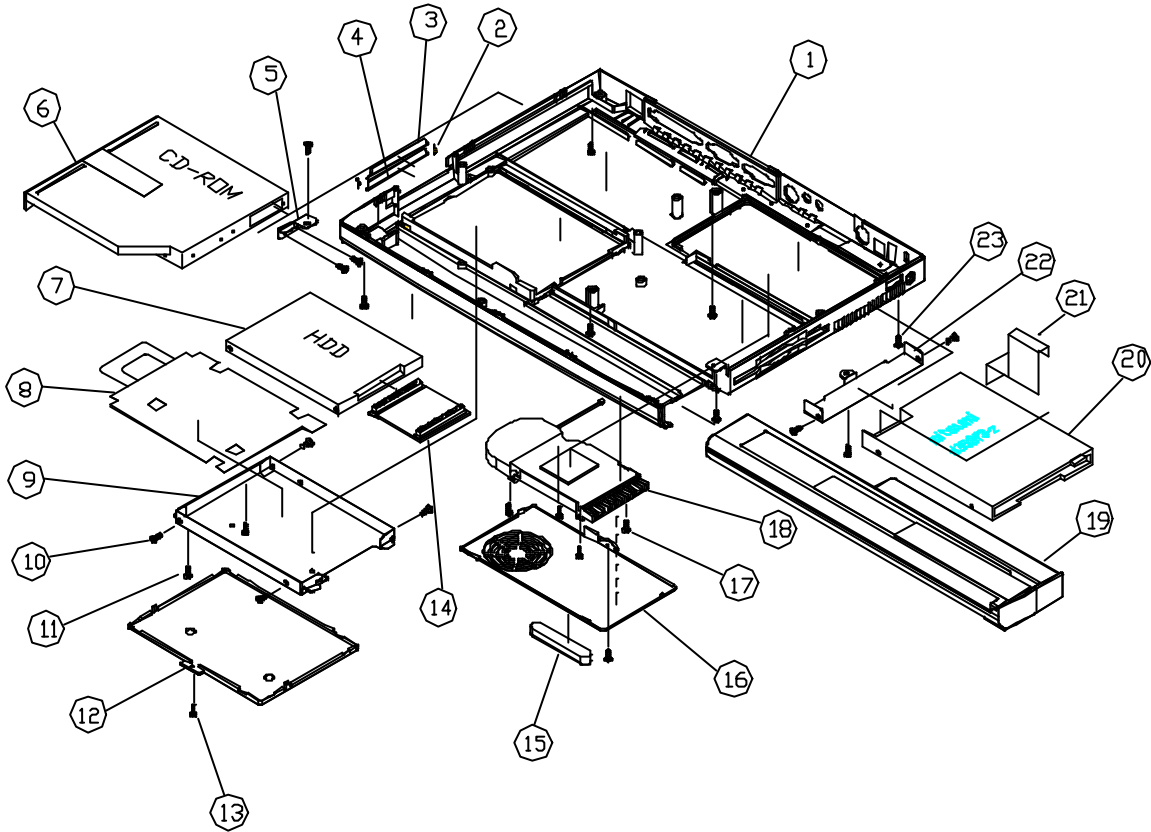

NO.	PART NUMBER	DESCRIPTION
1	50-U69022-70	BOTTOM CAB ASSY W/OUT TV OUT
2	40-102904-00	SPRING PCMCIA DOOR
3	50-206000-00	DOOR PCMCIA (U) 340
4	50-206001-00	DOOR PCMCIA (L) 340
5	40-302913-00	BRACKET CDROM 340
6	TEAC - 70-130104-00 QUANTA 70-130117-10	CD-ROM DRIVE
	TORISAN - 70-200010-00 QUANTA - 70-200010-10	DVD-ROM DRIVE
7	xxx	HDD
8	50-212902-00	MYLAR HDD 340
9	40-U75071-00	PLATE HDD 340
10	41-760230-03	SCREW M3.0*3
11	41-720120-04	SCREW M2.0*4
12	50-U69064-20	DOOR HDD 340
13	41-720120-04	SCREW M2.0*4
14	29U6905B-00	CABLE HDD 340
15		RUBBER FOOT 340
16	50-U69063-20	DOOR CPU 340
17		SCREW M2.5*4.5 PAN

18	70-U69711-00	THERMAL MODULE FOR 340S8
19	3200MAH- 23-523200-40 3600MAH 23-U53600-03	BATTERY
20	MITSUMI – 70-013144-UC TEAC –70-013144-U2	FDD
21	29-163403-00	FFC FDD
22	40-U69031-20	BRACKET FDD 340
23	41-720125-03	SCREW M2X0.45X8

## 7.4 LCD ASSEMBLY

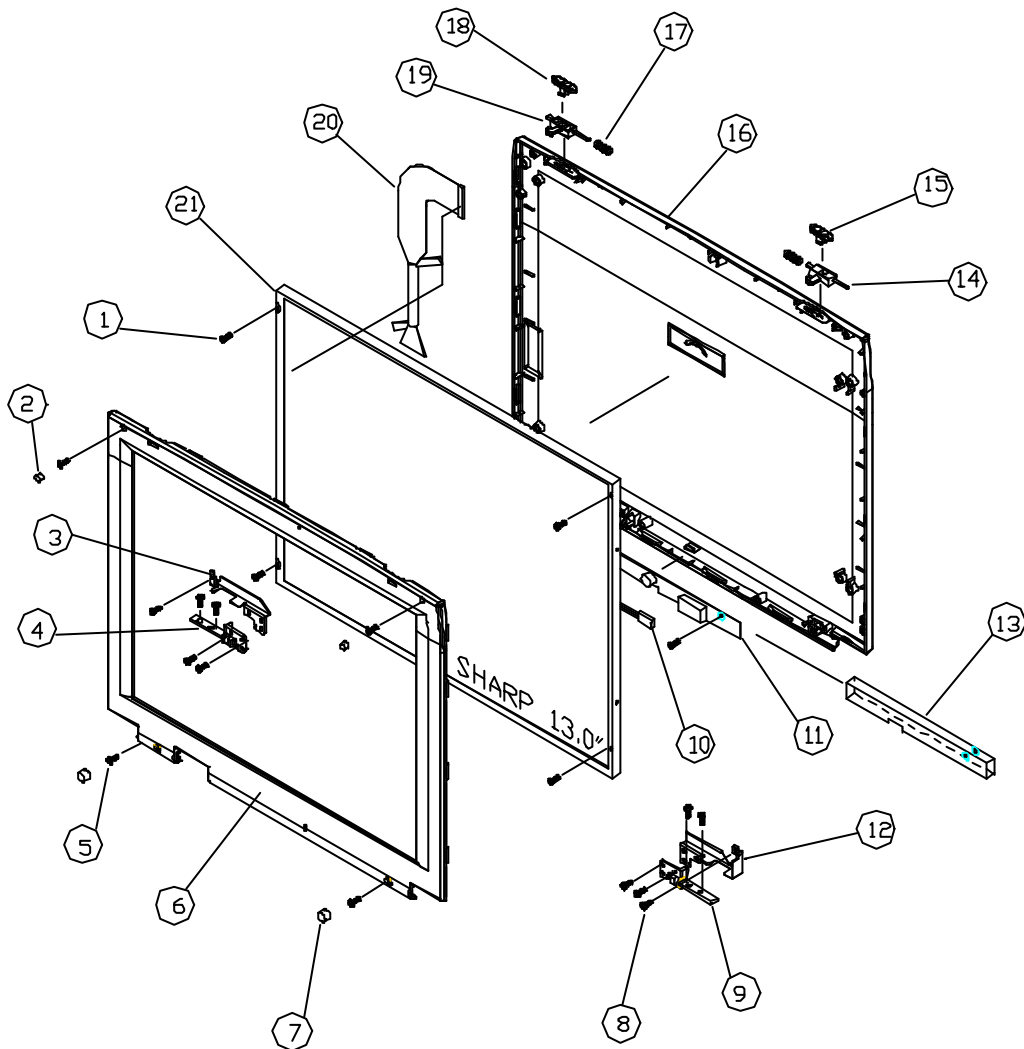

NO.	PART NUMBER	DESCRIPTION
1	41-720525-06	SCREW M2.5*6
2	52-012919-00	RUBBER FOR DISPLAY (T) 340
3	40-U78021-00	BRACKET (L) FOR LCD

4	40-152907-00	HINGE (L) A-TYPE 340
5	41-720525-06	SCREW M2.5*6
6	ID-2 12.1" – 50-33931-00 13.3" - 50-332932-00 14.1" - 50-332930-00  ID-4  13.3" – 50-U34032-00 14.1" - 50-U78032-00	FRONT CAB
7	52-012920-00	RUBBER FOR DISPLAY (B)
8	41-720120-04	SCREW M2.0*4
9	40-152909-00	HINGE ( R) A-TYPE 340
10	13.3" - 29-102901-00 14.1" – 29-102901-00	CABLE FOR LCD INVERTER
11	14.1" – 76-030527-00	INVERTER FOR
12	x	BRACKET ( R) FOR LCD
<b>NO.</b>		<b>DESCRIPTION</b>
13	50-212900-00	MYLAR FOR INVERTER 340
14	50-242912-10	HOOK LCD ( R ) 340
15	50-412913-00	KNOB LCD (340)
16	ID-2 12.1" – 50-342982-00 13.3" - 50-342981-00 14.1" - 50-342981-00  ID-4  13.3" – 50-342999-00 14.1" - 50-342900-10	BACK CABINET
17	40-101603-00	SPRING LCD GE-6200
18	50-412913-00	KNOB LCD 340
19	50-242912-00	HOOK LCD (L) 340
20	14.1" (uni ) – 29-U69051-00 14.1" (cmo) 29-U69051-00	CABLE FOR LCD
21	CMO 14.1 " – 72-10014B-00 UNIPAK 14.1" –72-100149-00	LCD